



**Hewlett Packard  
Enterprise**

## **HPE ProLiant DL325 Gen10 Server User Guide**

### **Abstract**

This document is for the person who installs, administers, and troubleshoots servers and storage systems. Hewlett Packard Enterprise assumes you are qualified in the servicing of computer equipment and trained in recognizing hazards in products with hazardous energy levels.

Part Number: P02217-003  
Published: August 2019  
Edition: 3

## Notices

The information contained herein is subject to change without notice. The only warranties for Hewlett Packard Enterprise products and services are set forth in the express warranty statements accompanying such products and services. Nothing herein should be construed as constituting an additional warranty. Hewlett Packard Enterprise shall not be liable for technical or editorial errors or omissions contained herein.

Confidential computer software. Valid license from Hewlett Packard Enterprise required for possession, use, or copying. Consistent with FAR 12.211 and 12.212, Commercial Computer Software, Computer Software Documentation, and Technical Data for Commercial Items are licensed to the U.S. Government under vendor's standard commercial license.

Links to third-party websites take you outside the Hewlett Packard Enterprise website. Hewlett Packard Enterprise has no control over and is not responsible for information outside the Hewlett Packard Enterprise website.

## Acknowledgments

AMD is a trademark of Advanced Micro Devices, Inc.

microSD is a trademark or a registered trademark of SD-3D in the United States, other countries of both.

Microsoft®, Windows®, and Windows Server® are either registered trademarks or trademarks of Microsoft Corporation in the United States and/or other countries.

Linux® is the registered trademark of Linus Torvalds in the U.S. and other countries.

Red Hat® Enterprise Linux is a registered trademark of Red Hat, Inc. in the United States and other countries.

VMware® ESXi™ and VMware vSphere® are registered trademarks or trademarks of VMware, Inc. in the United States and/or other jurisdictions.

# Contents

<b>Component identification.....</b>	<b>7</b>
Front panel components.....	7
Serial number/iLO information pull tab.....	8
Front panel LEDs and buttons.....	9
LFF drive model.....	9
SFF drive model.....	10
UID button functionality.....	11
Front panel LED power fault codes.....	11
Rear panel components.....	12
Rear panel LEDs.....	13
System board components.....	14
System maintenance switch descriptions.....	16
DIMM slot locations.....	16
DIMM label identification.....	17
Processor and socket components.....	18
Drive LEDs and buttons.....	19
Low profile LFF drive LED definitions.....	19
Hot-plug drive LED definitions.....	20
NVMe SSD LED definitions.....	20
NVMe SSD button actions.....	22
Drive bay numbering.....	22
PCIe expansion slot definitions.....	23
PCIe slot description.....	24
Fan bay numbering.....	25
<b>Operations.....</b>	<b>26</b>
Removing the bezel.....	26
Installing the bezel.....	26
Powering up the server.....	27
Powering down the server.....	27
Accessing the product rear panel.....	28
Extending the server from the rack.....	29
Removing the server from the rack.....	30
Removing the access panel.....	31
Installing the access panel.....	32
Removing the air baffle.....	33
Installing the air baffle.....	33
Removing a riser cage.....	34
Installing a riser cage.....	35
Removing a riser blank.....	36
Removing the media bay blank.....	38
Removing a Smart Array type-a modular controller.....	39
Removing a Smart Array PCIe plug-in controller.....	40
Remove the serial port.....	42
<b>Setup.....</b>	<b>44</b>
Optional service.....	44
Initial system installation.....	44

HPE Installation Service.....	44
Setting up the server.....	45
Operational requirements.....	47
Space and airflow requirements.....	47
Temperature requirements.....	48
Power requirements.....	48
Electrical grounding requirements.....	49
Server warnings and cautions.....	49
Rack warnings.....	50
Electrostatic discharge.....	51
Installing the server into the rack.....	51
POST screen options.....	53
Operating system.....	53
Installing the operating system with Intelligent Provisioning.....	54
Installing or deploying an operating system.....	54

## **Hardware options installation..... 55**

Introduction.....	55
Drive options.....	55
Drive installation guidelines .....	55
Installing a hot-plug drive.....	55
Drive cage options.....	58
Installing the 2SFF SAS/SATA drive cage.....	58
Installing the 2SFF NVMe drive cage.....	60
Storage controller options.....	61
Installing a Smart Array type-a modular controller.....	61
Installing a Smart Array PCIe plug-in controller.....	63
Configuring an HPE Smart Array Gen10 controller.....	66
Expansion board options.....	67
Installing an expansion board.....	67
Installing the GPU.....	69
Energy pack options.....	72
HPE Smart Storage Battery.....	72
HPE Smart Storage Hybrid Capacitor.....	72
Installing an energy pack.....	73
Installing the M.2 SSD enablement option.....	74
ODD options.....	75
Installing the ODD in LFF.....	75
Installing the ODD in SFF.....	77
Fan option.....	79
Fan population.....	79
Fan mode behavior.....	79
Installing a fan.....	79
Memory options.....	82
DIMM-processor compatibility.....	82
DIMM population information.....	82
Memory speed tables.....	83
Installing a DIMM.....	83
Installing the FlexibleLOM adapter option.....	84
Installing the intrusion detection switch.....	86
Installing the serial port.....	87
Redundant power supply (RPS) option.....	88
Hot-plug power supply calculations.....	88
Connecting a DC power cable to a DC power source.....	88
Installing the redundant power supply option.....	89

HPE Trusted Platform Module 2.0 Gen10 option.....	94
Overview.....	94
HPE Trusted Platform Module 2.0 Guidelines.....	94
Installing and enabling the HPE TPM 2.0 Gen10 Kit.....	95

## **Cabling..... 100**

Cabling guidelines.....	100
Cable routing: 4LFF drive model.....	101
Cable routing: 8SFF SAS/SATA drive model.....	104
Cable routing: 8SFF NVMe drive model.....	107
Cable routing: 2SFF SAS/SATA drive cage.....	108
Cable routing: 2SFF NVMe drive cage.....	109
Cable routing: Optical Drive.....	110
Cable routing: iLO service port.....	111
Cable routing: Power supply.....	112
Cable routing: GPU.....	113
Cable routing: Front I/O.....	113
Cable routing: USB 3.0.....	114
Cable routing: Serial port.....	116
Cable routing: Chassis Intrusion Detection switch.....	116
Cable routing: M.2 SSD.....	116
Cable routing: Controller backup power cable.....	118
Cable routing: Energy pack.....	120

## **Software and configuration utilities..... 121**

Server mode.....	121
Product QuickSpecs.....	121
Active Health System Viewer.....	121
Active Health System.....	121
HPE iLO 5.....	122
iLO Federation.....	122
iLO Service Port.....	123
iLO RESTful API.....	123
RESTful Interface Tool.....	124
iLO Amplifier Pack.....	124
Integrated Management Log.....	124
Intelligent Provisioning.....	124
Intelligent Provisioning operation.....	125
Management Security.....	125
Scripting Toolkit for Windows and Linux.....	126
UEFI System Utilities.....	126
Selecting the boot mode .....	126
Secure Boot.....	127
Launching the Embedded UEFI Shell .....	128
HPE Smart Storage Administrator.....	128
HPE InfoSight for servers .....	129
USB support.....	129
External USB functionality.....	129
Redundant ROM support.....	129
Safety and security benefits.....	129
Keeping the system current.....	129
Updating firmware or system ROM.....	129
Drivers.....	132
Software and firmware.....	132

Operating system version support.....	133
HPE Pointnext Portfolio.....	133
Proactive notifications.....	133
<b>System battery replacement.....</b>	<b>134</b>
System battery information.....	134
Removing and replacing the system battery.....	134
<b>Troubleshooting.....</b>	<b>136</b>
NMI functionality.....	136
Troubleshooting resources.....	136
<b>Safety, warranty, and regulatory information.....</b>	<b>137</b>
Regulatory information.....	137
Notices for Eurasian Economic Union.....	137
Turkey RoHS material content declaration.....	138
Ukraine RoHS material content declaration.....	138
Warranty information.....	138
<b>Specifications.....</b>	<b>139</b>
Environmental specifications.....	139
Mechanical specifications.....	140
Power supply specifications.....	140
HPE 500W Low Halogen Non-hot-plug Power Supply.....	140
HPE 500W Flex Slot Platinum Hot-plug Low Halogen Power Supply.....	141
HPE 800W Flex Slot Platinum Hot-plug Low Halogen Power Supply.....	142
HPE 800W Flex Slot Titanium Hot-plug Low Halogen Power Supply.....	143
HPE 800W Flex Slot Universal Hot-plug Low Halogen Power Supply.....	144
HPE 800W Flex Slot -48VDC Hot-plug Low Halogen Power Supply.....	144
HPE 1600W Flex Slot Platinum Hot-plug Low Halogen Power Supply.....	146
<b>Websites.....</b>	<b>147</b>
<b>Support and other resources.....</b>	<b>148</b>
Accessing Hewlett Packard Enterprise Support.....	148
Accessing updates.....	148
Customer self repair.....	149
Remote support.....	149
Documentation feedback.....	149

# Component identification

## Front panel components

### LFF drive model

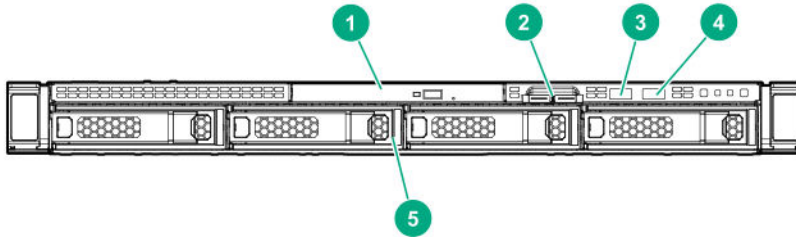

Item	Description
1	Optical drive (optional)
2	<b>Serial label pull tab</b>
3	iLO service port
4	USB 3.0 port
5	LFF drive bays (up to 4 LFF drives)

### SFF SAS/SATA drive model

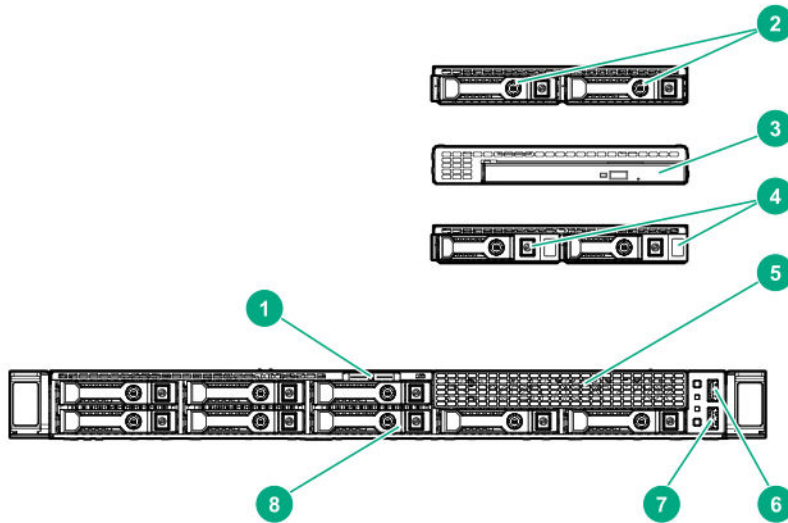

Item	Description
1	<b>Serial label pull tab</b>
2	2SFF SAS/SATA drive assembly (optional)
3	Optical drive assembly (optional)

Table Continued

Item	Description
4	2SFF NVMe drive assembly (optional)
5	Media bay blank
6	USB 3.0 port
7	iLO service port
8	SFF drive bays (up to 8 SAS/SATA drives)

### SFF NVMe drive model

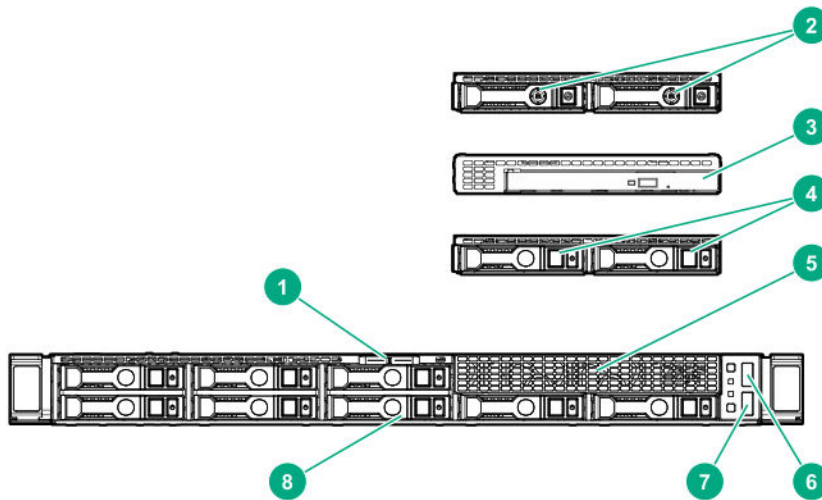

Item	Description
1	<b><u>Serial label pull tab</u></b>
2	2SFF SAS/SATA drive assembly (optional)
3	Optical drive assembly (optional)
4	2SFF NVMe drive assembly (optional)
5	Media bay blank
6	USB 3.0 port
7	iLO service port
8	SFF drive bays (up to 8 NVMe drives)

### Serial number/iLO information pull tab

The serial number/iLO information pull tab is double-sided. One side shows the server serial number and the customer asset tag label. The other side shows the default iLO account information and QR code label.

Use a mobile device to scan the QR code label to display the server mobile product page (<http://www.hpe.com/qref/dl325gen10>). This page contains links to server setup information, spare part numbers, QuickSpecs, troubleshooting resources, and other useful product links.



# Front panel LEDs and buttons

## LFF drive model

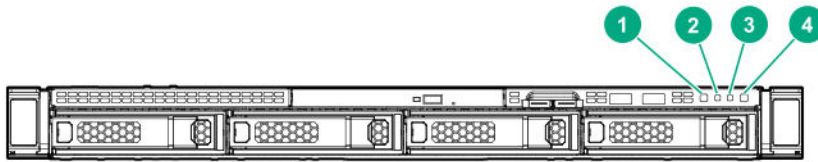

Item	Description	Status
1	UID button/LED	<p>Solid blue = Activated</p> <p>Flashing blue:</p> <ul style="list-style-type: none"><li>• 1 flash per second = Remote management or firmware upgrade in progress</li><li>• 4 flashes per second = iLO manual reboot sequence initiated</li><li>• 8 flashes per second = iLO manual reboot sequence in progress</li></ul> <p>Off = Deactivated</p>
2	NIC status LED	<p>Solid green = Link to network</p> <p>Flashing green (1 flash per second) = Network active</p> <p>Off = No network activity</p>
3	Health LED	<p>Solid green = Normal</p> <p>Flashing green (1 flash per second) = iLO is rebooting</p> <p>Flashing amber = System degraded<sup>1</sup></p> <p>Flashing red (1 flash per second) = System critical<sup>1</sup></p>
4	Power On/Standby button and system power LED	<p>Solid green = System on</p> <p>Flashing green (1 flash per second) = Performing power on sequence</p> <p>Solid amber = System in standby</p> <p>Off = No power present <sup>2</sup></p>

<sup>1</sup> If the health LED indicates a degraded or critical state, review the system Integrated Management Log (IML) or use HPE iLO to review the system health status.

<sup>2</sup> If the system power LED is off, verify the following conditions:

- Facility power is present.
- The power supply is installed and is working correctly.
- The power cord is attached and is connected to a power source.
- The front I/O cable is connected.

If all LEDs described in this table flash simultaneously, a power fault has occurred. For more information, see "**Power fault LEDs**".

## SFF drive model

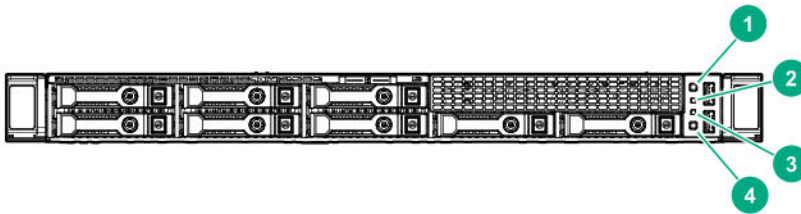

Item	Description	Status
1	Power On/Standby button and system power LED	<p>Solid green = System on</p> <p>Flashing green (1 flash per second) = Performing power on sequence</p> <p>Solid amber = System in standby</p> <p>Off = No power present <sup>1</sup></p>
2	Health LED	<p>Solid green = Normal</p> <p>Flashing green (1 flash per second) = iLO is rebooting</p> <p>Flashing amber = System degraded<sup>2</sup></p> <p>Flashing red (1 flash per second) = System critical<sup>2</sup></p>

*Table Continued*

Item	Description	Status
3	NIC status LED	Solid green = Link to network Flashing green (1 flash per second) = Network active Off = No network activity
4	UID button/LED	Solid blue = Activated Flashing blue: <ul style="list-style-type: none"> <li>• 1 flash per second = Remote management or firmware upgrade in progress</li> <li>• 4 flashes per second = iLO manual reboot sequence initiated</li> <li>• 8 flashes per second = iLO manual reboot sequence in progress</li> </ul> Off = Deactivated

<sup>1</sup> If the system power LED is off, verify the following conditions:

- Facility power is present.
- The power supply is installed and is working correctly.
- The power cord is attached and is connected to a power source.
- The front I/O cable is connected.

<sup>2</sup> If the health LED indicates a degraded or critical state, review the system Integrated Management Log (IML) or use HPE iLO to review the system health status.

If all LEDs described in this table flash simultaneously, a power fault has occurred. For more information, see "**Power fault LEDs**".

## UID button functionality

The UID button can be used to display the Server Health Summary when the server will not power on. For more information, see the iLO user guide on the Hewlett Packard Enterprise website (<http://www.hpe.com/support/ilo-docs>).

## Front panel LED power fault codes

The following table provides a list of power fault codes, and the subsystems that are affected. Not all power faults are used by all servers.

Subsystem	LED behavior
System board	1 flash
Processor	2 flashes
Memory	3 flashes
Riser board PCIe slots	4 flashes

*Table Continued*

Subsystem	LED behavior
FlexibleLOM	5 flashes
Removable HPE Smart Array SR Gen10 controller	6 flashes
System board PCIe slots	7 flashes
Power backplane or storage backplane	8 flashes
Power supply	9 flashes

## Rear panel components

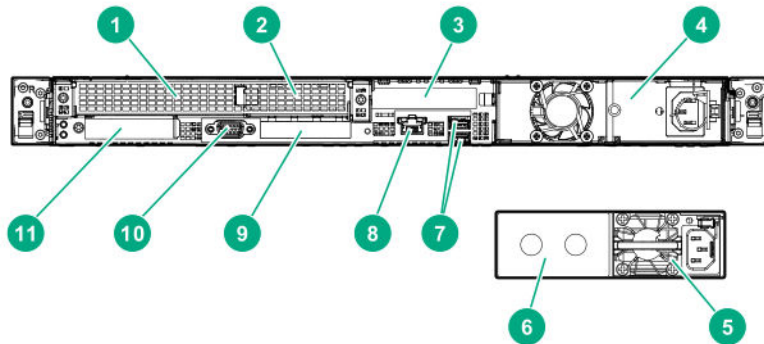

Item	Description
1	Slot 1 PCIe3 x16 (16, 8, 4, 1) <sup>1</sup>
2	Slot 2 PCIe3 x8 (8, 4, 1) <sup>1</sup>
3	Slot 3 PCIe3 x16 (16, 8, 4, 1) <sup>1</sup> /Serial port (optional)
4	Standard power supply (non-hot plug)
5	Flex Slot power supply 1 (hot-plug)
6	Flex Slot power supply 2 (hot-plug)
7	USB 3.0 ports (2)
8	iLO Management port
9	NIC ports (if equipped)
10	Video port
11	FlexibleLOM (optional)

<sup>1</sup> For more information, see [PCIe riser board slot definitions](#).

# Rear panel LEDs

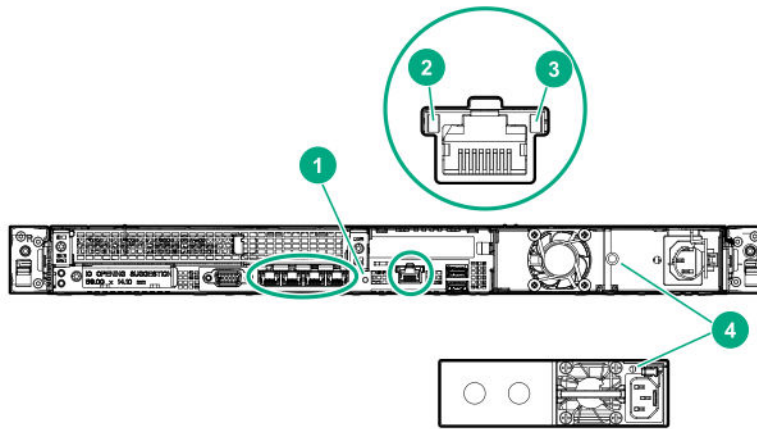

Item	LED	Status	Definition
1	UID	Solid blue	Activated
		Flashing blue	1 flash per sec = Remote management or firmware upgrade in progress
			4 flashes per sec = iLO manual reboot sequence initiated
			8 flashes per sec = iLO manual reboot sequence in progress
2	NIC link <sup>1</sup>	Off	Deactivated
		Green	Network link
		Off	No network link
3	NIC status <sup>1</sup>	Solid Green	Linked to network
		Flashing green	Network active
		Off	No network activity
4	Power supply	Solid green	Normal
		Off	System is off or power supply has failed.

<sup>1</sup> For servers equipped with onboard NIC ports

# System board components

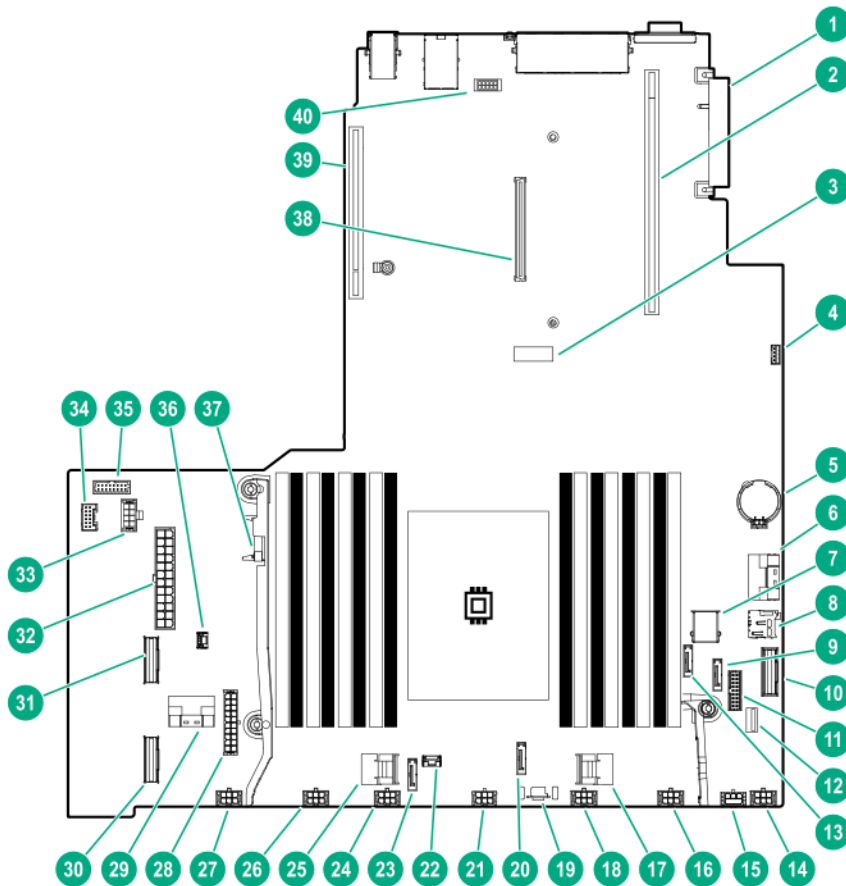

Item	Description
1	FlexibleLOM connector
2	Primary PCIe riser connector
3	<b>System maintenance switch</b>
4	iLO Service Port connector
5	System battery
6	NVMe connector port 4A
7	Internal USB 3.0 connector
8	microSD card slot <sup>1</sup>
9	x1 SATA port 4
10	NVMe connector port 5A
11	Front I/O connector
12	Front USB 3.0 connector
13	x1 SATA port 3

Table Continued

Item	Description
14	Fan connector 7
15	GPU power connector
16	Fan connector 6
17	x4 SATA port 2
18	Fan connector 5
19	TPM connector
20	x1 SATA port 2
21	Fan connector 4
22	SATA management port
23	x1 SATA port 1
24	Fan connector 3
25	x4 SATA port 1
26	Fan connector 2
27	Fan connector 1
28	Drive backplane power connector
29	NVMe connector port 3A
30	NVMe connector port 2A
31	NVMe connector port 1A
32	Power connector for Standard or Flex Slot power supply
33	Power connector for Flex Slot power supply
34	Energy pack connector
35	Sideband connector for Flex Slot power supply
36	Chassis intrusion detection switch connector
37	Chassis intrusion detection switch (optional)
38	Smart Array modular controller connector <sup>2</sup>
39	Secondary PCIe riser connector
40	Serial port connector

<sup>1</sup> If the memory card connected to the microSD slot is not visible in Windows Device Manager, in the menu bar, click **View > Show hidden device**.

<sup>2</sup> This connector is not available if the expansion board is installed in the secondary riser slot 3.

## System maintenance switch descriptions

Position	Default	Function
S1 <sup>1</sup>	Off	Off = iLO security is enabled. On = iLO security is disabled.
S2	Off	Reserved
S3	Off	Reserved
S4	Off	Reserved
S5 <sup>1</sup>	Off	Off = Power-on password is enabled. On = Power-on password is disabled.
S6 <sup>1, 2, 3</sup>	Off	Off = No function On = Restore default manufacturing settings
S7	Off	Reserved
S8	—	Reserved
S9	—	Reserved
S10	—	Reserved
S11	—	Reserved
S12	—	Reserved

<sup>1</sup> To access the redundant ROM, set S1, S5, and S6 to On.

<sup>2</sup> When the system maintenance switch position 6 is set to the On position, the system is prepared to restore all configuration settings to their manufacturing defaults.

<sup>3</sup> When the system maintenance switch position 6 is set to the On position and Secure Boot is enabled, some configurations cannot be restored. For more information, see **Secure Boot** on page 127.

## DIMM slot locations

DIMM slots are numbered sequentially (1 through 16). The supported AMP modes use the letter assignments for population guidelines.

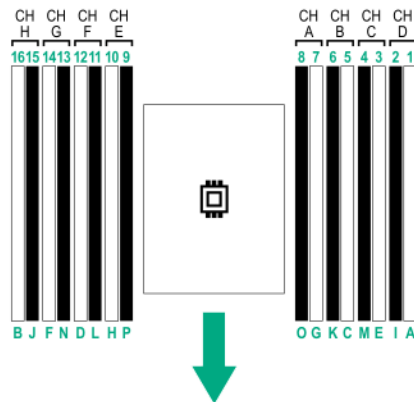



The arrow points to the front of the server.

## DIMM label identification

To determine DIMM characteristics, see the label attached to the DIMM. The information in this section helps you to use the label to locate specific information about the DIMM.

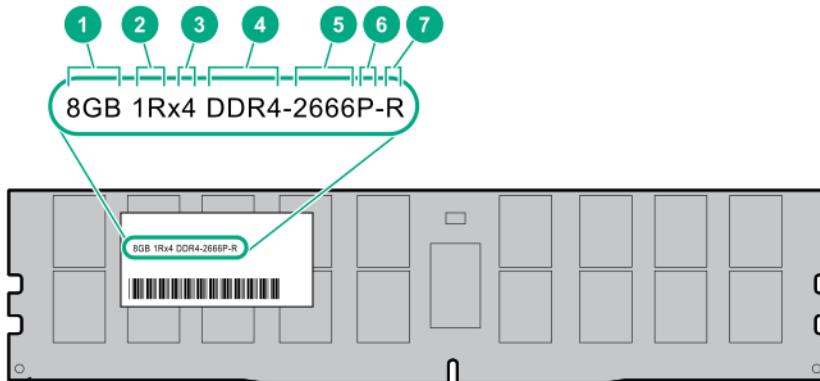

Item	Description	Example
1	Capacity	8 GB 16 GB 32 GB 64 GB 128 GB
2	Rank	1R = Single rank 2R = Dual rank 4R = Quad rank 8R = Octal rank
3	Data width on DRAM	x4 = 4-bit x8 = 8-bit x16 = 16-bit
4	Memory generation	PC4 = DDR4
5	Maximum memory speed	2133 MT/s 2400 MT/s 2666 MT/s 2933 MT/s

*Table Continued*

Item	Description	Example
6	CAS latency	P = CAS 15-15-15 T = CAS 17-17-17 U = CAS 20-18-18 V = CAS 19-19-19 (for RDIMM, LRDIMM) V = CAS 22-19-19 (for 3DS TSV LRDIMM) Y = CAS 21-21-21 (for RDIMM, LRDIMM) Y = CAS 24-21-21 (for 3DS TSV LRDIMM)
7	DIMM type	R = RDIMM (registered) L = LRDIMM (load reduced) E = Unbuffered ECC (UDIMM)

For more information about product features, specifications, options, configurations, and compatibility, see the HPE DDR4 SmartMemory QuickSpecs on the Hewlett Packard Enterprise website (<http://www.hpe.com/support/DDR4SmartMemoryQS>).

## Processor and socket components

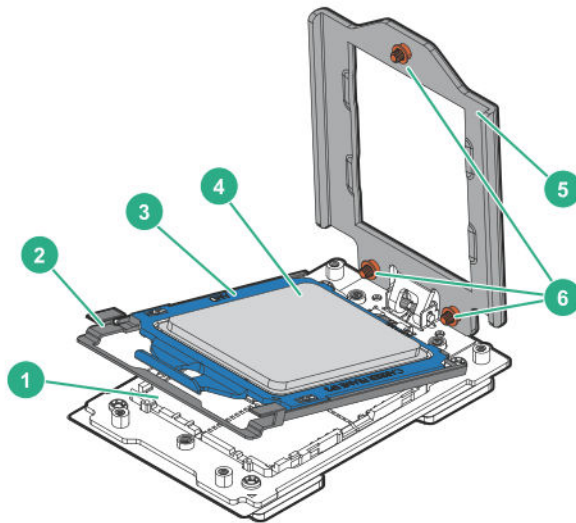

Item	Description
1	Pin field
2	Rail frame
3	Carrier frame
4	Processor

*Table Continued*

Item	Description
5	Force frame
6	Captive screws (Torx T-20)

## Drive LEDs and buttons

### Low profile LFF drive LED definitions

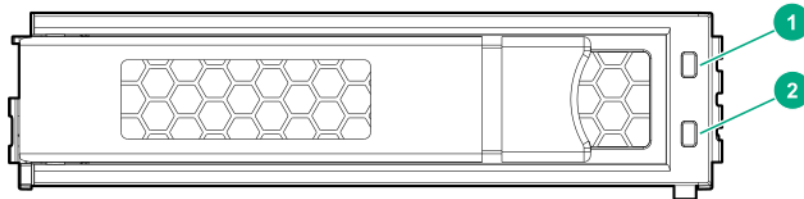

Item	LED	Status	Definition
1	Fault \Locate	Solid amber	The drive has failed.
		Solid blue	The drive is operating normally and being identified by a management application.
		Flashing amber/blue (1 flash per second)	The drive has failed, or a predictive failure alert has been received for this drive; it also has been identified by a management application.
		Flashing amber (1 flash per second)	A predictive failure alert has been received for this drive. Replace the drive as soon as possible.
2	Online \Activity	Solid green	The drive is online and has no activity.
		Flashing green (4 flashes per second)	The drive is operating normally and has activity.
		Flashing green (1 flash per second)	The drive is doing one of the following: <ul style="list-style-type: none"> <li>• Rebuilding</li> <li>• Performing a RAID migration</li> <li>• Performing a strip size migration</li> <li>• Performing a capacity expansion</li> <li>• Performing a logical drive extension</li> <li>• Erasing</li> <li>• Spare part activation</li> </ul>
		Off	The drive is not configured by a RAID controller or a spare drive.

## Hot-plug drive LED definitions

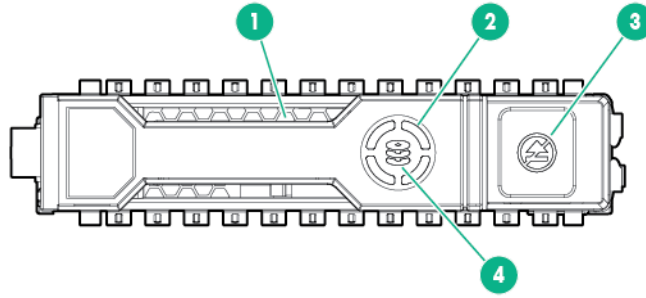

Item	LED	Status	Definition
1	Locate	Solid blue	The drive is being identified by a host application.
		Flashing blue	The drive carrier firmware is being updated or requires an update.
2	Activity ring	Rotating green	Drive activity
		Off	No drive activity
3	Do not remove	Solid white	Do not remove the drive. Removing the drive causes one or more of the logical drives to fail.
		Off	Removing the drive does not cause a logical drive to fail.
4	Drive status	Solid green	The drive is a member of one or more logical drives.
		Flashing green	The drive is doing one of the following: <ul style="list-style-type: none"> <li>Rebuilding</li> <li>Performing a RAID migration</li> <li>Performing a strip size migration</li> <li>Performing a capacity expansion</li> <li>Performing a logical drive extension</li> <li>Erasing</li> <li>Spare part activation</li> </ul>
		Flashing amber/green	The drive is a member of one or more logical drives and predicts the drive will fail.
		Flashing amber	The drive is not configured and predicts the drive will fail.
		Solid amber	The drive has failed.
		Off	The drive is not configured by a RAID controller or a spare drive.

## NVMe SSD LED definitions

The NVMe SSD is a PCIe bus device. A device attached to a PCIe bus cannot be removed without allowing the device and bus to complete and cease the signal/traffic flow.



**CAUTION:** Do not remove an NVMe SSD from the drive bay while the Do not remove LED is flashing. The Do not remove LED flashes to indicate that the device is still in use. Removing the NVMe SSD before the device has completed and ceased signal/traffic flow can cause loss of data.

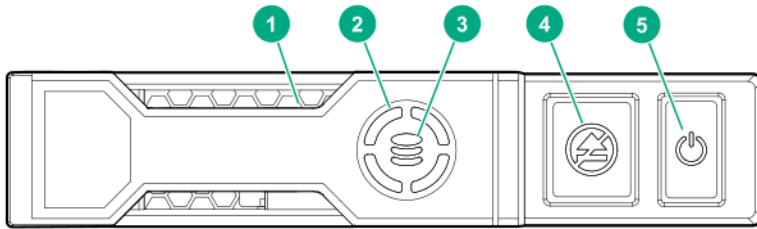

Item	LED	Status	Definition
1	Locate	Solid blue	The drive is being identified by a host application.
		Flashing blue	The drive carrier firmware is being updated or requires an update.
2	Activity ring	Rotating green	Drive activity
		Off	No drive activity
3	Drive status	Solid green	The drive is a member of one or more logical drives.
		Flashing green	The drive is doing one of the following: <ul style="list-style-type: none"> <li>Rebuilding</li> <li>Performing a RAID migration</li> <li>Performing a stripe size migration</li> <li>Performing a capacity expansion</li> <li>Performing a logical drive extension</li> <li>Erasing</li> </ul>
		Flashing amber/green	The drive is a member of one or more logical drives and predicts the drive will fail.
		Flashing amber	The drive is not configured and predicts the drive will fail.
		Solid amber	The drive has failed.
		Off	The drive is not configured by a RAID controller.
		Off	The drive is not configured by a RAID controller.
4	Do not remove	Solid white	Do not remove the drive. The drive must be ejected from the PCIe bus prior to removal.
		Flashing white	The drive ejection request is pending.
		Off	The drive has been ejected.
5	Power	Solid green	Do not remove the drive. The drive must be ejected from the PCIe bus prior to removal.

*Table Continued*

Item	LED	Status	Definition
		Flashing green	The drive ejection request is pending.
		Off	The drive has been ejected.

## NVMe SSD button actions

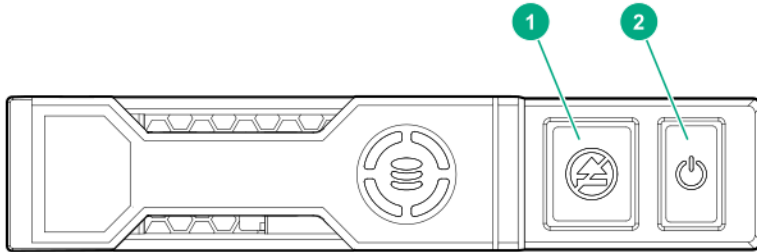

Item	Button	Action
1	Do Not Remove	Press to open the release lever.
2	Power	Press to request PCIe ejection. Removal request can be denied by the: <ul style="list-style-type: none"> <li>RAID controller (one or more of the logical drives could fail)</li> <li>Operating system</li> </ul>

## Drive bay numbering

- LFF drive model

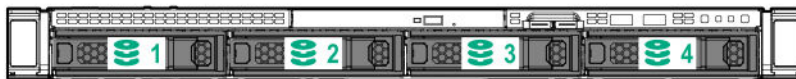

- SFF SAS/SATA drive model

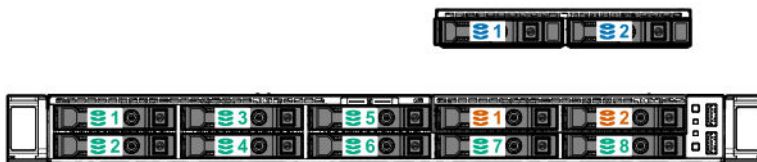

Drive numbering colors	Description
Green	8SFF SAS/SATA drives
Blue	2SFF NVMe drives (optional)
Orange	2SFF SAS/SATA drives (optional)

- SFF NVMe drive model

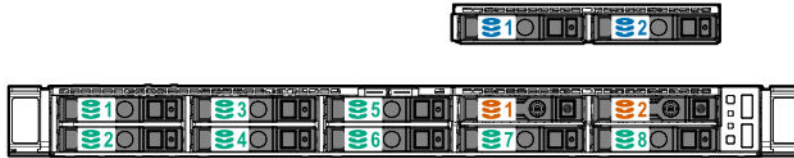

Drive numbering colors	Description
Green	8SFF NVMe drives
Blue	2SFF NVMe drives (optional)
Orange	2SFF SAS/SATA drives (optional)

## PCIe expansion slot definitions

Slot	Type	Form factor	Connector link width	Negotiable link width
1 <sup>1</sup>	PCIe 3.0	FL, FH <sup>2</sup>	x16	16, 8, 4, 1
2	PCIe 3.0	HL, HH <sup>3</sup>	x8	8, 4, 1
3 <sup>4</sup>	PCIe 3.0	HL, HH <sup>3</sup>	x16	16, 8, 4, 1

<sup>1</sup> GPU can be supported only in slot 1.

<sup>2</sup> FL, FH=Full length, full height

<sup>3</sup> HL, HH=Half length, half height

<sup>4</sup> Slot 3 is unavailable when a Smart Array type-a modular controller is installed in the system.

# PCIe slot description

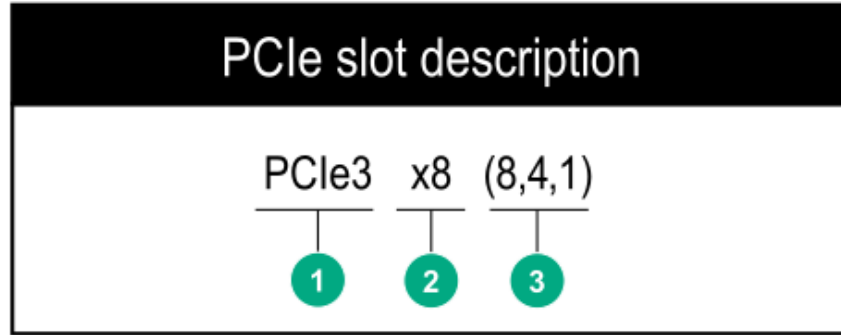

Item	Description	Definition
1	PCI Express version	<p>Each PCIe version corresponds to a specific data transfer rate between the processor and peripheral devices. Generally, a version update corresponds to an increase in transfer rate.</p> <ul style="list-style-type: none"><li>• PCIe 1.x</li><li>• PCIe 2.x</li><li>• PCIe 3.x</li></ul> <p>The PCIe technology is under constant development. For the latest information, see the <a href="#">PCI-SIG website</a>.</p>
2	Physical connector link width	<p>PCIe devices communicate through a logical connection called an interconnect or link. At the physical level, a link is composed of one or more lanes. The number of lanes is written with an "x" prefix with x16 being the largest size in common use.</p> <ul style="list-style-type: none"><li>• x1</li><li>• x2</li><li>• x4</li><li>• x8</li><li>• x16</li></ul>
3	Negotiable link width	<p>These numbers correspond to the maximum link bandwidth supported by the slot.</p>



# Fan bay numbering



The arrow points to the front of the server.

# Operations

## Removing the bezel

### Procedure

1. Remove the Kensington security lock.
2. Remove the bezel.
  - a. Press the latch.
  - b. Open the bezel.
  - c. Detach the bezel from the latch ear.

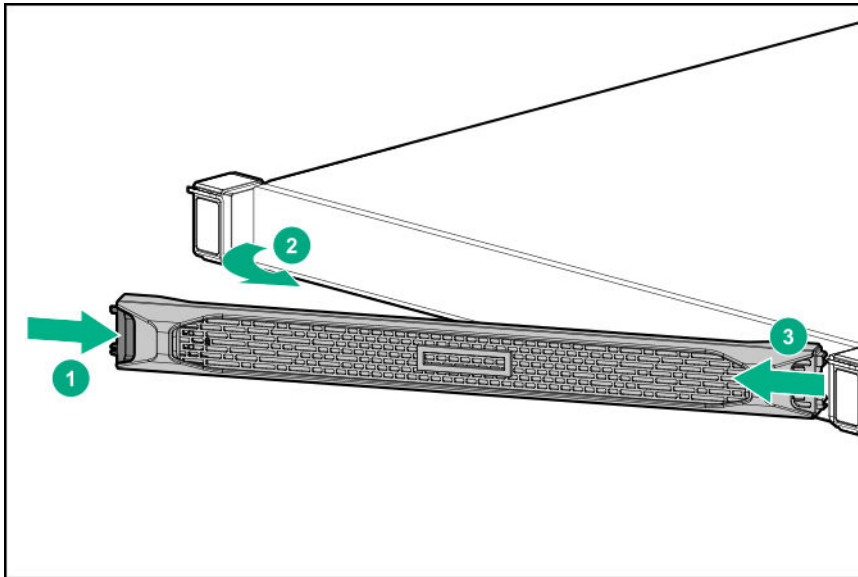

## Installing the bezel

### Procedure

1. Install the bezel.
  - a. Attach the bezel to the latch ear.
  - b. Press the latch.
  - c. Close the bezel.

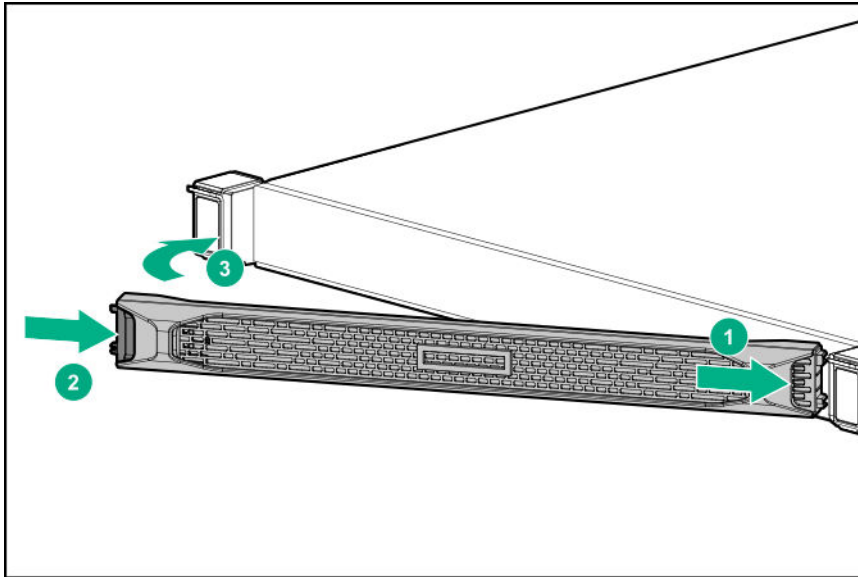

2. Install the Kensington security lock.

## Powering up the server

### Procedure

1. **Remove the bezel.**
2. Use one of the following methods to power up the server:
  - Press the Power On/Standby button.
  - Use the virtual power button through iLO.
3. **Install the bezel.**

## Powering down the server

---

**!** **IMPORTANT:** When the server is in standby mode, auxiliary power is still being provided to the system.

---

### Prerequisites

Before powering down the server for any upgrade or maintenance procedures, perform a backup of critical server data and programs.

### Procedure

1. **Remove the bezel.**
2. To power down the server, use one of the following methods.
  - Press and release the Power On/Standby button.

This method initiates a controlled shutdown of applications and the OS before the server enters standby mode.

- Press and hold the Power On/Standby button for more than 4 seconds to force the server to enter standby mode.

This method forces the server to enter standby mode without properly exiting applications and the OS. If an application stops responding, you can use this method to force a shutdown.

- Use a virtual power button selection through iLO.

This method initiates a controlled remote shutdown of applications and the OS before the server enters standby mode.

3. Verify that the server is in standby mode by observing that the system power LED is amber.

## Accessing the product rear panel

### Procedure

1. Release the cable management arm.

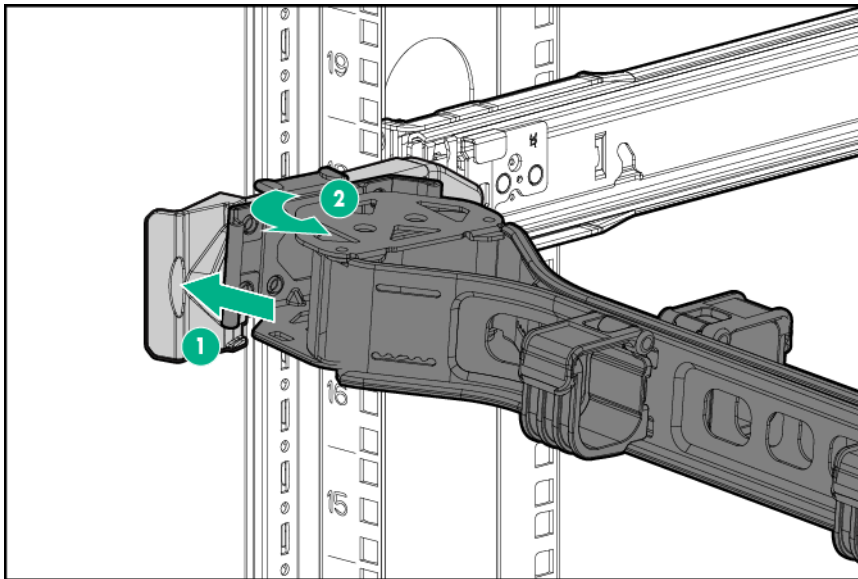

2. Open the cable management arm.

The cable management arm can be right-mounted or left-mounted.

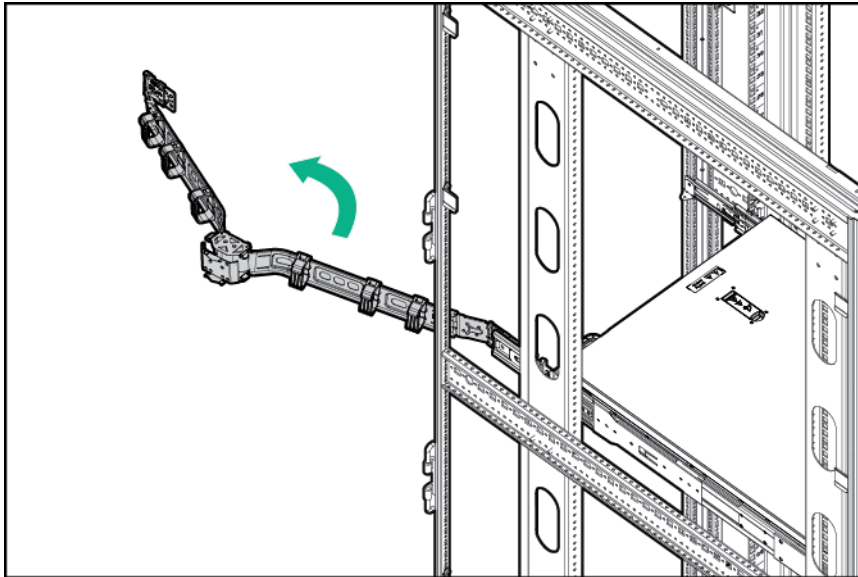

## Extending the server from the rack

To perform this procedure, you will need a T-25 screwdriver.

**NOTE:** If the optional cable management arm option is installed, you can extend the server without powering down the server or disconnecting peripheral cables and power cords. These steps are only necessary with the standard cable management solution.



**WARNING:** To reduce the risk of personal injury or equipment damage, be sure that the rack is adequately stabilized before extending a component from the rack.



**WARNING:** To reduce the risk of personal injury, be careful when pressing the server rail-release latches and sliding the server into the rack. The sliding rails could pinch your fingers.

### Procedure

1. If installed, **remove the bezel.**
2. **Power down the server.**
3. Disconnect all peripheral cables and power cords.
4. Do the following:
  - a. Open the latches on both sides of the server.
  - b. If necessary, use a T-25 Torx screwdriver to loosen the shipping screws.
  - c. Slide the server out of the rack.

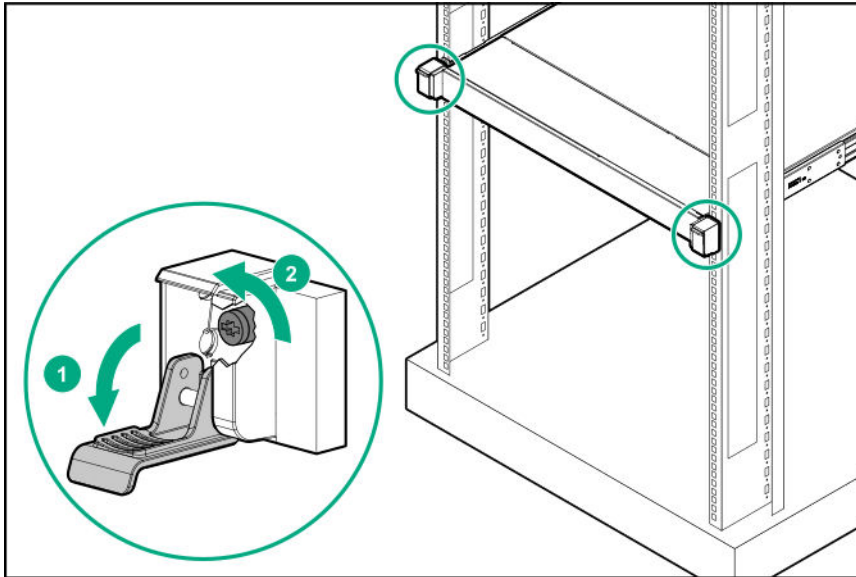

5. Extend the server on the rack rails until the server rail-release latches engage.

## Removing the server from the rack



**WARNING:** This server is heavy. To reduce the risk of personal injury or damage to the equipment:

- Observe local occupational health and safety requirements and guidelines for manual material handling.
- Get help to lift and stabilize the product during installation or removal, especially when the product is not fastened to the rails.

Hewlett Packard Enterprise recommends that a minimum of two people are required for all rack server installations. If the server is installed higher than chest level, a third person may be required to help align the server.

- Use caution when installing the server in or removing the server from the rack. The server is unstable when not fastened to the rails.

### Procedure

1. If installed, **remove the bezel.**
2. **Power down the server.**
3. **Extend the server from the rack.**
4. Remove the server from the rack. Press and hold both server rail-release latches while removing the server.

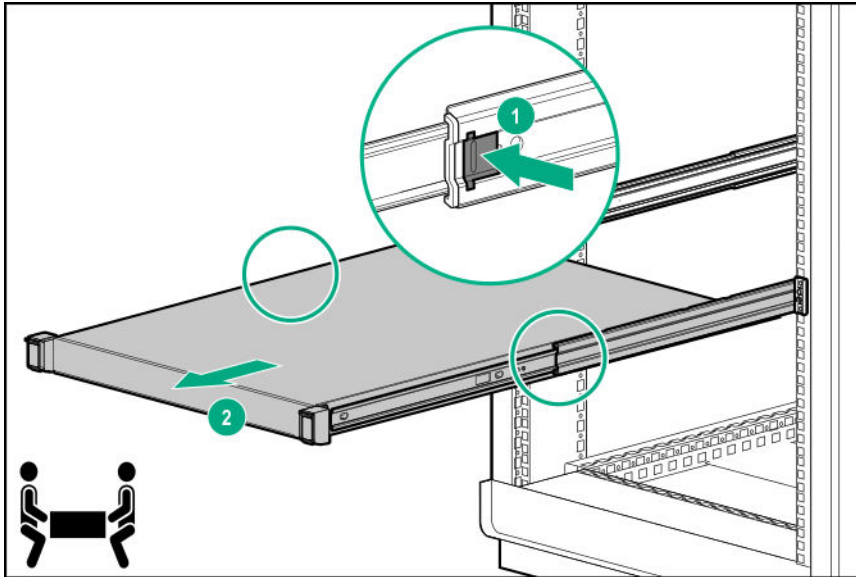

5. Place the server on a sturdy, level surface.

## Removing the access panel

- ⚠ CAUTION:** Do not operate the server for long periods with the access panel open or removed. Operating the server in this manner results in improper airflow and improper cooling that can lead to thermal damage.

### Prerequisites

Before you perform this procedure, make sure that you have a T-15 Torx screwdriver available.

### Procedure

1. If installed, **remove the bezel.**
2. **Power down the server.**
3. Remove all power:
  - a. Disconnect each power cord from the power source.
  - b. Disconnect each power cord from the server.
4. Do one of the following:
  - **Extend the server from the rack.**
  - **Remove the server from the rack.**
5. Remove the access panel:
  - a. If necessary, unlock the access panel latch.
  - b. Press the release button and pull up the latch to disengage the access panel from the chassis.
  - c. Lift up the access panel to remove the panel from the chassis.

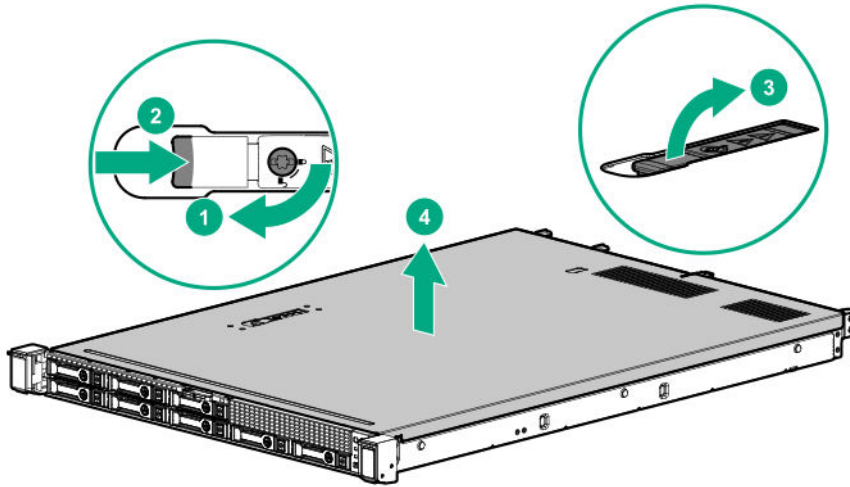

## Installing the access panel

### Prerequisites

Before you perform this procedure, make sure that you have a T-15 Torx screwdriver available.

### Procedure

1. Place the access panel on top of the server with the latch open.  
Allow the panel to extend past the rear of the server approximately 1.25 cm (0.5 in).
2. Push down on the latch.  
The access panel slides to a closed position.
3. Tighten the security screw on the latch, if needed.

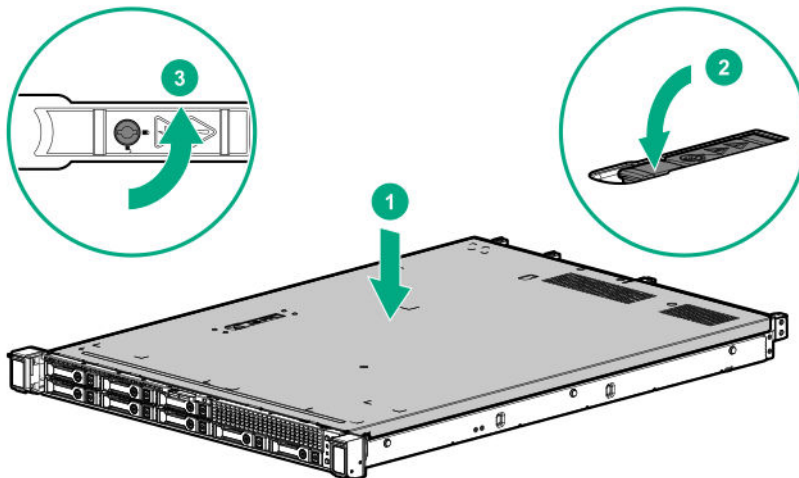



# Removing the air baffle

**⚠ CAUTION:** For proper cooling, do not operate the server without the access panel, baffles, expansion slot covers, or blanks installed. If the server supports hot-plug components, minimize the amount of time the access panel is open.

## Procedure

1. If installed, **remove the bezel**.
2. **Power down the server**.
3. Remove all power:
  - a. Disconnect each power cord from the power source.
  - b. Disconnect each power cord from the server.
4. Do one of the following:
  - **Extend the server from the rack**.
  - **Remove the server from the rack**.
5. **Remove the access panel**.
6. Remove the air baffle.

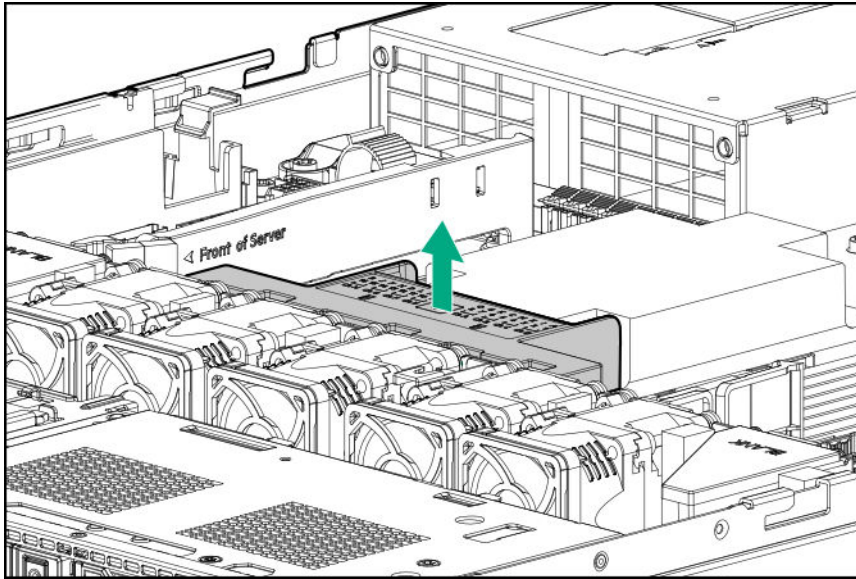

# Installing the air baffle

## Procedure

1. Observe the following alert.

---

**⚠ CAUTION:** For proper cooling, do not operate the server without the access panel, baffles, expansion slot covers, or blanks installed. If the server supports hot-plug components, minimize the amount of time the access panel is open.

---

2. Install the air baffle.

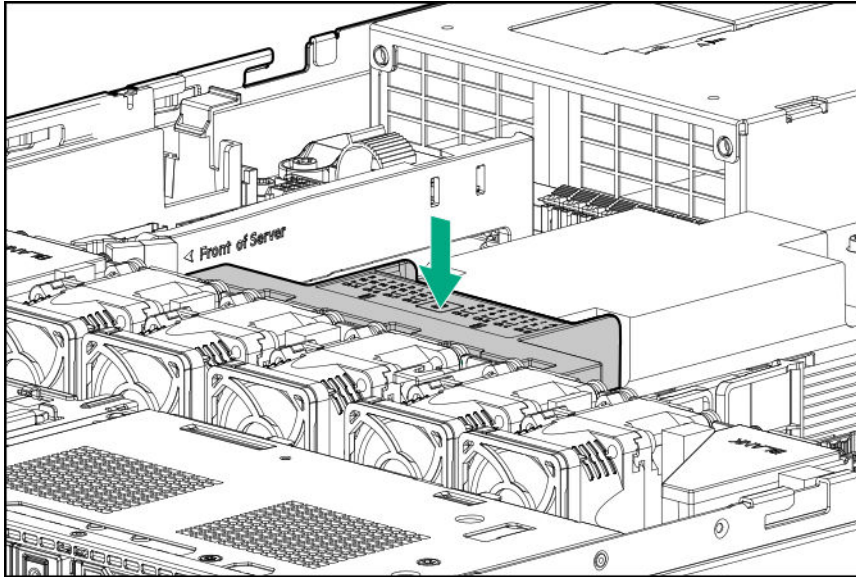

## Removing a riser cage

---

**⚠ WARNING:** To reduce the risk of personal injury from hot surfaces, allow the drives and the internal system components to cool before touching them.

---

**⚠ CAUTION:** To prevent damage to the server or expansion boards, power down the server, and disconnect all power cords before removing or installing the riser board.

---

### Procedure

1. **Power down the server.**
2. Remove all power:
  - a. Disconnect each power cord from the power source.
  - b. Disconnect each power cord from the server.
3. Disconnect all peripheral cables from the server.
4. Do one of the following:
  - **Extend the server from the rack.**
  - **Remove the server from the rack.**
5. **Remove the access panel.**
6. Disconnect all cables from the existing expansion boards.
7. Remove the riser cage.

- Primary riser cage

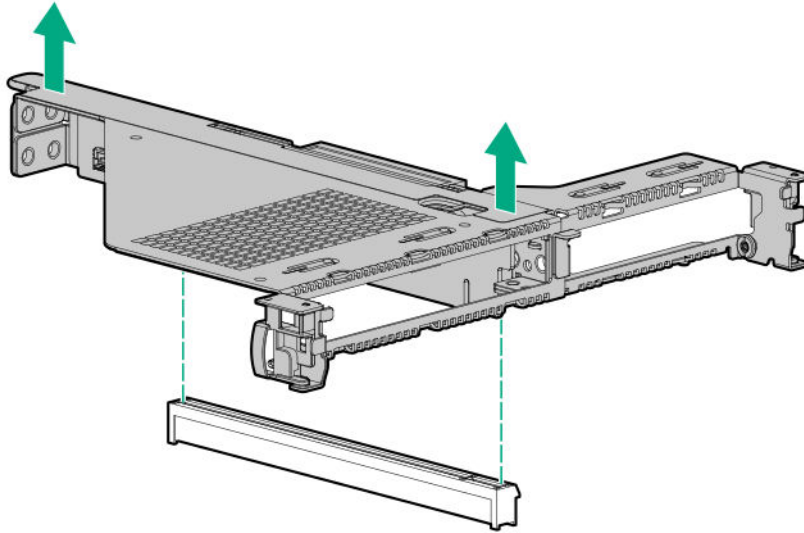

- Secondary riser

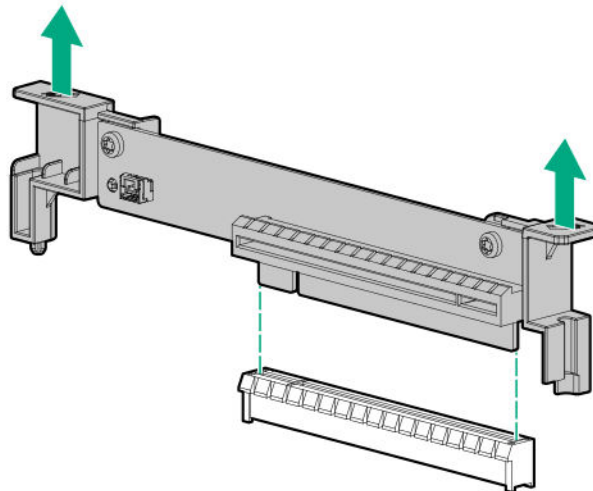

## Installing a riser cage

### Procedure

1. Install the riser cage.
  - Primary riser cage

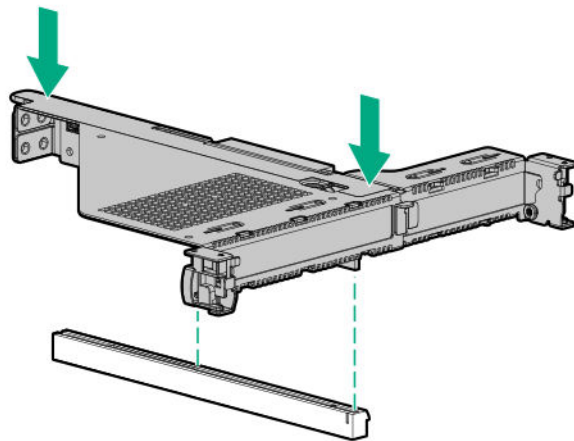

- Secondary riser

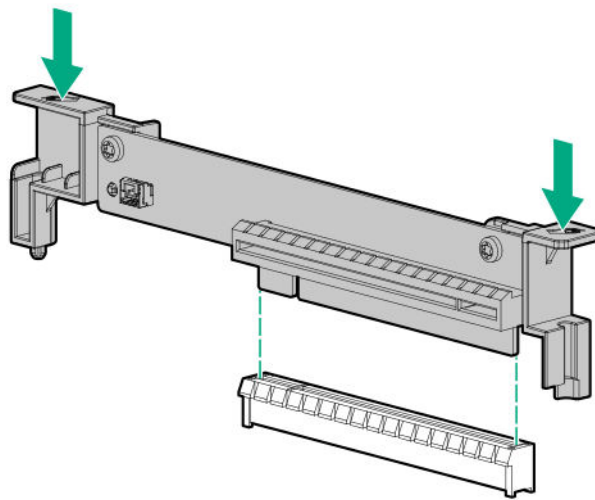

- 2. Install the access panel.**
- 3. Install the server into the rack.**
4. Connect all peripheral cables to the server.
5. Connect each power cord to the server.
6. Connect each power cord to the power source.
- 7. Power up the server.**

## Removing a riser blank

- 
- ⚠ CAUTION:** To prevent improper cooling and thermal damage, do not operate the server unless all PCI slots have either a riser blank or an expansion board installed.
-

## Prerequisites

Before you perform this procedure, make sure that you have a T-15 Torx screwdriver available.

## Procedure

1. **Install the access panel.**
2. **Install the server into the rack.**
3. Connect all peripheral cables to the server.
4. Connect each power cord to the server.
5. Connect each power cord to the power source.
6. **Power up the server.**
7. If removing the riser blank from primary riser, **remove the primary riser cage.**
8. Remove the riser blank.
  - Primary riser slot 1

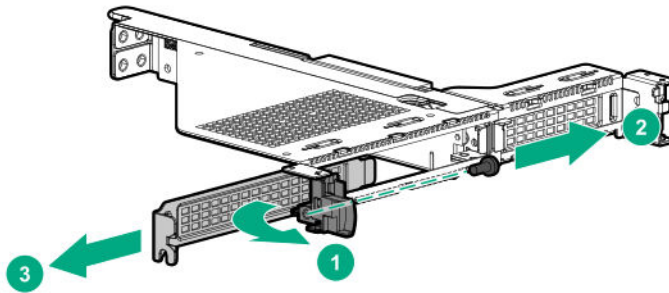

- Primary riser slot 2

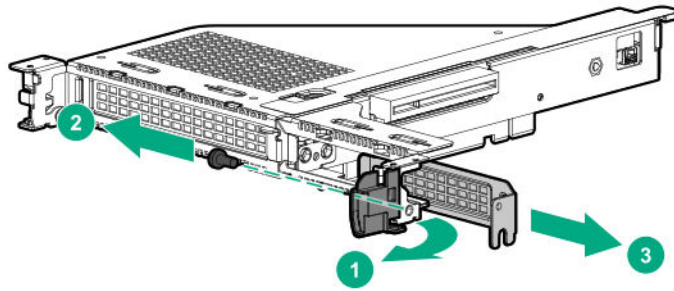

- Secondary riser slot 3

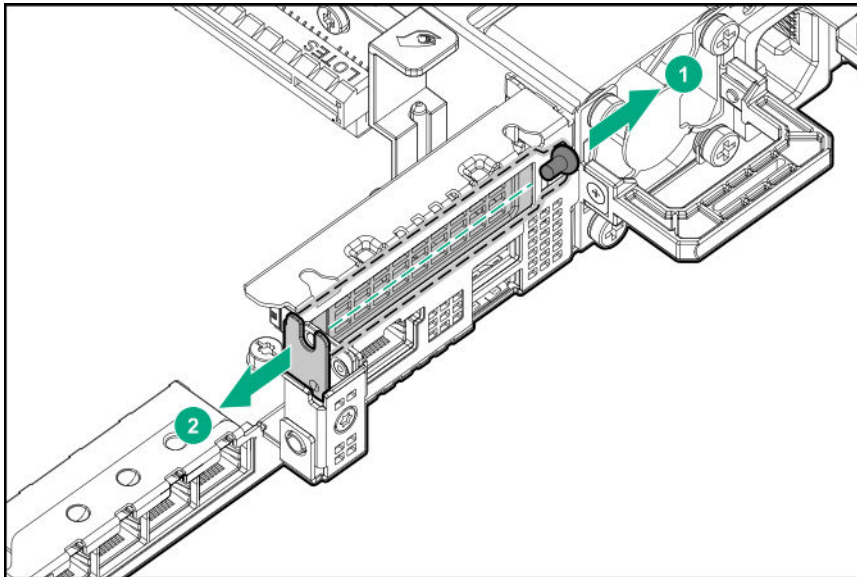

## Removing the media bay blank

To perform this procedure, you will need a T-10 screwdriver.

### Procedure

1. If installed, **remove the bezel.**
2. **Power down the server.**
3. Remove all power:
  - a. Disconnect each power cord from the power source.
  - b. Disconnect each power cord from the server.
4. Do one of the following:

- **Extend the server from the rack.**
  - **Remove the server from the rack.**
- Remove the access panel.**
  - Remove the media bay blank.

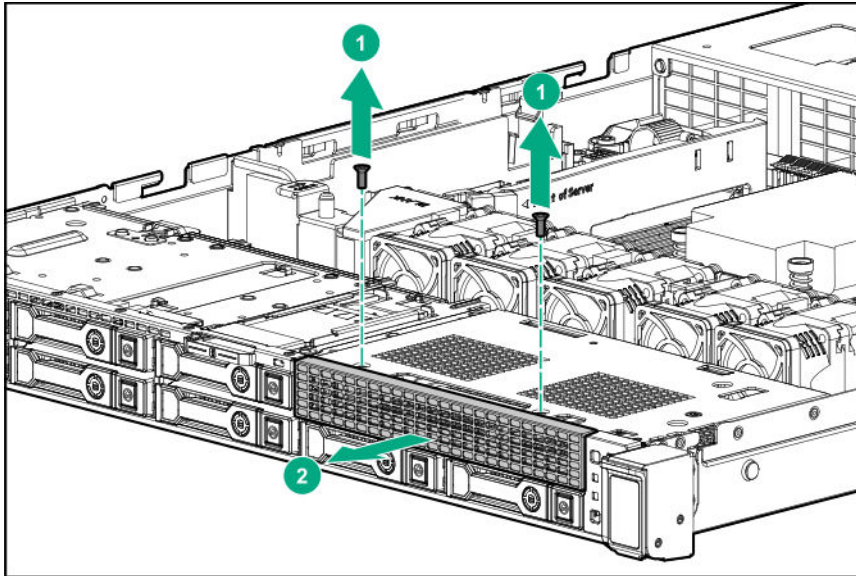

## Removing a Smart Array type-a modular controller

### Prerequisites

Before you perform this procedure, make sure that you have a T-15 Torx screwdriver available.

### Procedure

1. If installed, **remove the bezel.**
2. **Power down the server.**
3. Remove all power:
  - a. Disconnect each power cord from the power source.
  - b. Disconnect each power cord from the server.
4. Disconnect all peripheral cables from the server.
5. Do one of the following:
  - **Extend the server from the rack.**
  - **Remove the server from the rack.**
6. **Remove the access panel.**
7. Disconnect all cables from the storage controller.
8. Remove the Smart Array type-a modular controller:

- a. Loosen the controller board thumbscrews.
- b. Release the snap-in latch.
- c. Use the pull-up tab to remove the controller from the system board.

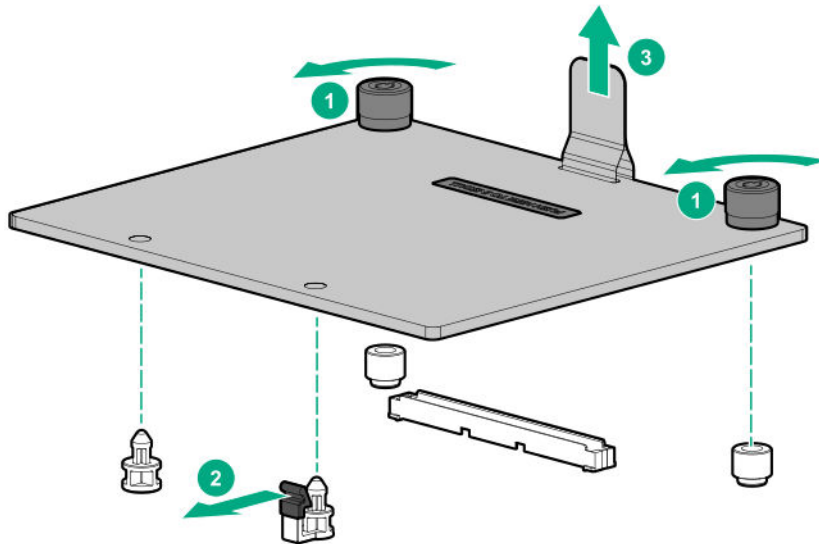

## Removing a Smart Array PCIe plug-in controller

### Prerequisites

Before you perform this procedure, make sure that you have a T-15 Torx screwdriver available.

### Procedure

1. **Power down the server.**
2. Remove all power:
  - a. Disconnect each power cord from the power source.
  - b. Disconnect each power cord from the server.
3. Disconnect all peripheral cables from the server.
4. Do one of the following:
  - **Extend the server from the rack.**
  - **Remove the server from the rack.**
5. **Remove the access panel.**
6. If removing the PCIe plug-in controller from slot 1 or 2:
  - a. Disconnect all cables from the expansion board.
  - b. **Removing a riser cage** on page 34.
  - c. Remove the Smart Array controller.



- Slot 1

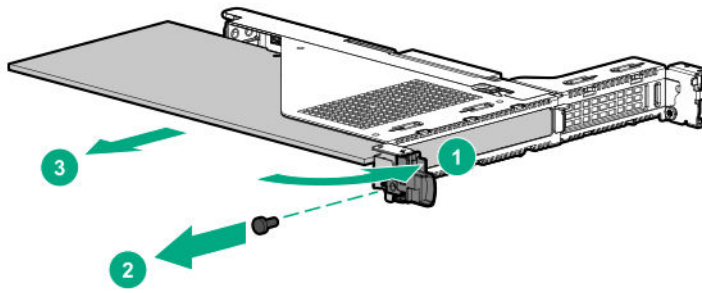

- Slot 2

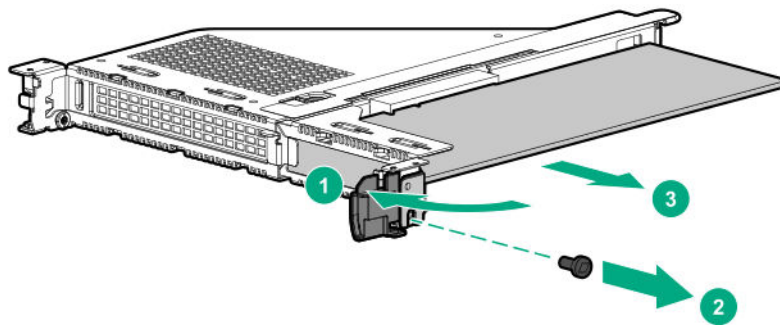

7. If removing the PCIe plug-in controller from slot 3:
  - a. Disconnect all cables from the expansion board.
  - b. Remove the controller.

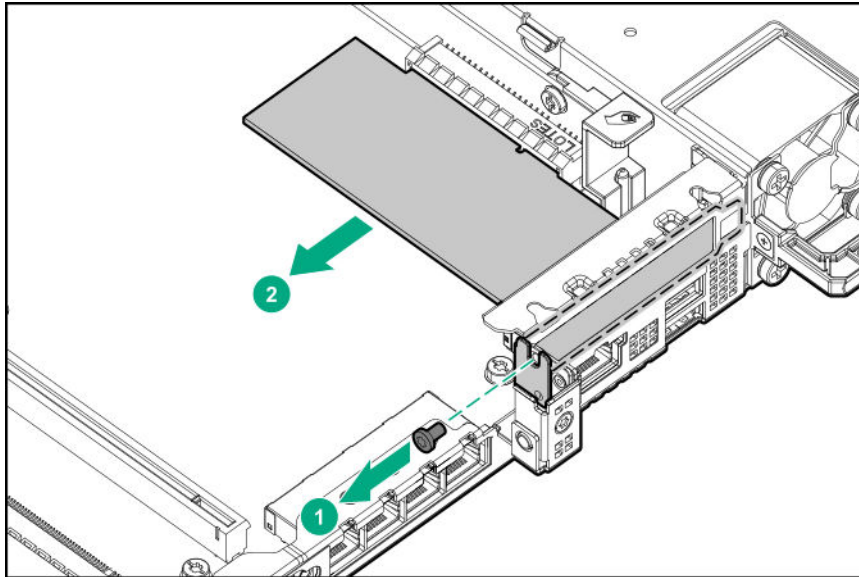

## Remove the serial port

### Prerequisites

Before you perform this procedure, make sure that you have a nut driver available.

### Procedure

1. If installed, **remove the bezel.**
2. **Power down the server.**
3. Remove all power:
  - a. Disconnect each power cord from the power source.
  - b. Disconnect each power cord from the server.
4. Do one of the following:
  - **Extend the server from the rack.**
  - **Remove the server from the rack.**
5. **Remove the access panel.**
6. Disconnect the serial port cable from the system board.
7. Remove the serial port assembly.

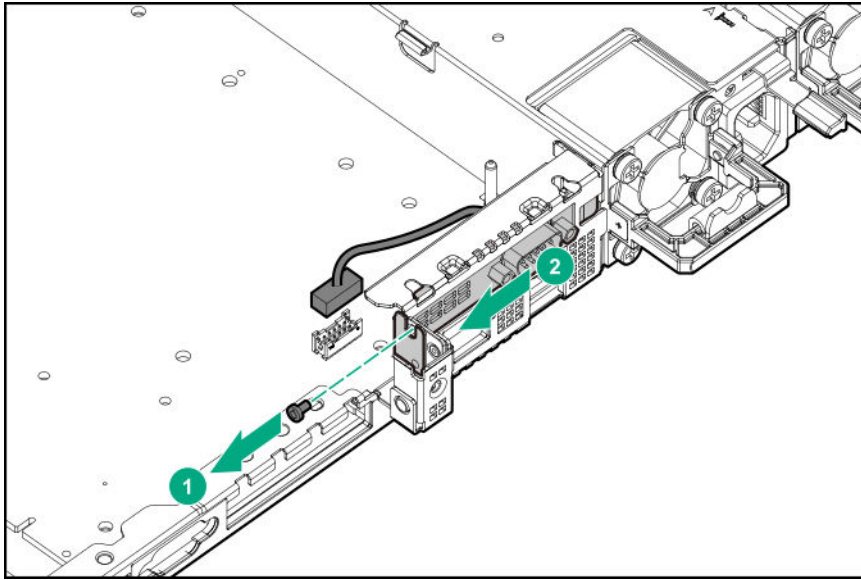

# Setup

## Optional service

Delivered by experienced, certified engineers, Hewlett Packard Enterprise support services help you keep your servers up and running with support packages tailored specifically for HPE ProLiant systems. Hewlett Packard Enterprise support services let you integrate both hardware and software support into a single package. A number of service level options are available to meet your business and IT needs.

Hewlett Packard Enterprise support services offer upgraded service levels to expand the standard product warranty with easy-to-buy, easy-to-use support packages that will help you make the most of your server investments. Some of the Hewlett Packard Enterprise support services for hardware, software or both are:

- Foundation Care – Keep systems running.
  - 6-Hour Call-to-Repair<sup>1</sup>
  - 4-Hour 24x7
  - Next Business Day
- Proactive Care – Help prevent service incidents and get you to technical experts when there is one.
  - 6-Hour Call-to-Repair<sup>1</sup>
  - 4-Hour 24x7
  - Next Business Day
- Deployment service for both hardware and software
- Hewlett Packard Enterprise Education Services – Help train your IT staff.

<sup>1</sup>The time commitment for this repair service might vary depending on the geographical region of site. For more service information available in your site, contact your local [\*\*Hewlett Packard Enterprise support center\*\*](#).

For more information on Hewlett Packard Enterprise support services, see the [\*\*Hewlett Packard Enterprise website\*\*](#).

## Initial system installation

Depending on your technical expertise and the complexity of the product, for the initial system installation, select one of the following options:

- [\*\*Ordering the HPE Installation Service\*\*](#)
- [\*\*Setting up the server\*\*](#) on page 45

## HPE Installation Service

HPE Installation Service provides basic installation of Hewlett Packard Enterprise branded equipment, software products, as well as HPE-supported products from other vendors that are sold by HPE or by HPE authorized resellers. The Installation Service is part of a suite of HPE deployment services that are designed to give users the peace of mind that comes from knowing that their HPE and HPE-supported products have been installed by an HPE specialist.

The HPE Installation Service provides the following benefits:

- Installation by an HPE authorized technical specialist.
- Verification prior to installation that all service prerequisites are met.

- Delivery of the service at a mutually scheduled time convenient to your organization.
- Allows your IT resources to stay focused on their core tasks and priorities.
- Full coverage during the warranty period for products that require installation by an HPE authorized technical specialist.

For more information on the features, limitations, provisions, and ordering information of the HPE Installation Service, see this Hewlett Packard Enterprise website:

**<http://www.hpe.com/support/installation-service>**

## Setting up the server

### Prerequisites

Before setting up the server:

- Download the latest SPP:
  - <http://www.hpe.com/servers/spp/download>**
  - Support validation required
- Verify that your OS or virtualization software is supported:
  - <http://www.hpe.com/info/ossupport>**
- Read the HPE UEFI requirements for ProLiant servers on the **Hewlett Packard Enterprise website**. If the UEFI requirements are not met, you might experience boot failures or other errors when installing the operating system.
- Obtain the storage driver if needed:
  - Download it from the HPE Support Center website:
    - <http://www.hpe.com/support/hpesc>**
  - Extract it from the SPP.
- Read the operational requirements for the server:
  - Operational requirements** on page 47
- Read the safety and compliance information on the HPE website:
  - <http://www.hpe.com/support/safety-compliance-enterpriseproducts>**

### Procedure

#### Unbox the server

**1.** Unbox the server and verify the contents:

- Server
- Power cord
- Rack-mounting hardware (optional)
- Documentation

The server does not ship with OS media. All system software and firmware is preloaded on the server.

#### Install the hardware options

2. (Optional) Install hardware options. For installation instructions, see [Hardware options installation](#) on page 55.

### **Rack the server**

#### **3. Install the server in a rack.**

4. Decide how to manage the server:

- Locally: use a KVM switch or a connect a keyboard, monitor, and mouse.
- Remotely: connect to the iLO web interface and run a remote console:

- a. Verify the following:

- iLO is licensed to use the remote console feature.

If iLO is not licensed, visit the HPE website:

[\*\*http://www.hpe.com/info/ilo\*\*](http://www.hpe.com/info/ilo)

- The iLO management port is connected to a secure network.

- b. Using a browser, navigate to the iLO web interface, and then log in.

`https://<iLO hostname or IP address>`

Note the following:

- The iLO hostname is located on the serial number/iLO information pull tab.
- If a DHCP server assigns the IP address, the IP address appears on the boot screen.
- If a static IP address is assigned, use that IP address.
- The default login credentials are located on the serial label pull tab.

- c. In the side navigation, click the **Remote Console & Media** link, and then launch a remote console.

### **Power on the server**

5. Press the Power On/Standby button.

For remote management, use the iLO virtual power button.

### **Update the firmware**

6. Using the SPP, **update the following:**

- System ROM
- Storage controller
- Network adapters
- Intelligent Provisioning

### **Set up storage**

7. Set up the storage. Do one of the following:

- To configure the server to boot from a SAN, see the following guide:

[\*\*https://www.hpe.com/info/boot-from-san-config-guide\*\*](https://www.hpe.com/info/boot-from-san-config-guide)

- If an HPE Smart Array SR controller is installed, use HPE Smart Storage Administrator to create arrays:

- a. From the boot screen, press **F10** to run Intelligent Provisioning.
- b. From Intelligent Provisioning, run **HPE Smart Storage Administrator**.
- If no controller is installed, do one of the following:
  - AHCI is enabled by default. You can deploy an OS or virtualization software.
  - Disable AHCI, enable software RAID, and then create an array:
    - a. From the boot screen, press **F9** to run UEFI System Utilities.
    - b. From the UEFI System Utilities screen, select **System Configurations > BIOS/Platform Configuration (RBSU) > Storage Options > SATA Controller Options > Embedded SATA Configuration > Smart Array SW RAID Support**.
    - c. Enable **Smart Array SW RAID Support**.
    - d. Save the configuration and reboot the server.
    - e. Create an array:
      - I. From the boot screen, press **F9** to run UEFI System Utilities.
      - II. From the UEFI System Utilities screen, select **System Configuration > Embedded Storage: HPE Smart Storage S100i SR Gen10 > Array Configuration > Create Array**.

#### Deploy an OS or virtualization software

#### 8. Deploy an OS or virtualization software. Do one of the following:

- Press **F10** at the POST screen.

For Intelligent Provisioning 3.30 and later, you are prompted to select whether you want to enter the Intelligent Provisioning or HPE SMB Setup mode. After you have selected a mode, you must reprovision the server to change the mode that launches when you boot to **F10**.

- Manually deploy an OS.

- a. Insert the installation media.

For remote management, click **Virtual Drives** in the iLO remote console to mount images, drivers, or files to a virtual folder. If a storage driver is required to install the OS, use the virtual folder to store the driver.

- b. Press **F11** at boot screen to select the boot device.

- c. After the OS installed, **update the drivers**.

#### Register the server

- 9. To experience quicker service and more efficient support, register the server at the HPE website:

**<https://myenterpriselicense.hpe.com>**

## Operational requirements

### Space and airflow requirements

To allow for servicing and adequate airflow, observe the following space and airflow requirements when deciding where to install a rack:

- Leave a minimum clearance of 63.5 cm (25 in) in front of the rack.
- Leave a minimum clearance of 76.2 cm (30 in) behind the rack.
- Leave a minimum clearance of 121.9 cm (48 in) from the back of the rack to the back of another rack or row of racks.

Hewlett Packard Enterprise servers draw in cool air through the front door and expel warm air through the rear door. Therefore, the front and rear rack doors must be adequately ventilated to allow ambient room air to enter the cabinet, and the rear door must be adequately ventilated to allow the warm air to escape from the cabinet.

---

**⚠ CAUTION:** To prevent improper cooling and damage to the equipment, do not block the ventilation openings.

---

When vertical space in the rack is not filled by a server or rack component, the gaps between the components cause changes in airflow through the rack and across the servers. Cover all gaps with blanking panels to maintain proper airflow.

**⚠ CAUTION:** Always use blanking panels to fill empty vertical spaces in the rack. This arrangement ensures proper airflow. Using a rack without blanking panels results in improper cooling that can lead to thermal damage.

---

The 9000 and 10000 Series Racks provide proper server cooling from flow-through perforations in the front and rear doors that provide 64 percent open area for ventilation.

**⚠ CAUTION:** If a third-party rack is used, observe the following additional requirements to ensure adequate airflow and to prevent damage to the equipment:

- Front and rear doors—If the 42U rack includes closing front and rear doors, you must allow 5,350 sq cm (830 sq in) of holes evenly distributed from top to bottom to permit adequate airflow (equivalent to the required 64 percent open area for ventilation).
  - Side—The clearance between the installed rack component and the side panels of the rack must be a minimum of 7 cm (2.75 in).
- 

## Temperature requirements

To ensure continued safe and reliable equipment operation, install or position the system in a well-ventilated, climate-controlled environment.

The maximum recommended ambient operating temperature (TMRA) for most server products is 35°C (95°F). The temperature in the room where the rack is located must not exceed 35°C (95°F).

**⚠ CAUTION:** To reduce the risk of damage to the equipment when installing third-party options:

- Do not permit optional equipment to impede airflow around the server or to increase the internal rack temperature beyond the maximum allowable limits.
  - Do not exceed the manufacturer's TMRA.
- 

## Power requirements

Installation of this equipment must comply with local and regional electrical regulations governing the installation of information technology equipment by licensed electricians. This equipment is designed to operate in installations covered by NFPA 70, 1999 Edition (National Electric Code) and NFPA-75, 1992 (Code for Protection of Electronic Computer/Data Processing Equipment). For electrical power ratings on options, refer to the product rating label or the user documentation supplied with that option.



---

 **WARNING:** To reduce the risk of personal injury, fire, or damage to the equipment, do not overload the AC supply branch circuit that provides power to the rack. Consult the electrical authority having jurisdiction over wiring and installation requirements of your facility.

---

 **CAUTION:** Protect the server from power fluctuations and temporary interruptions with a regulating uninterruptible power supply. This device protects the hardware from damage caused by power surges and voltage spikes and keeps the system in operation during a power failure.

---

## Electrical grounding requirements

The server must be grounded properly for proper operation and safety. In the United States, you must install the equipment in accordance with NFPA 70, 1999 Edition (National Electric Code), Article 250, as well as any local and regional building codes. In Canada, you must install the equipment in accordance with Canadian Standards Association, CSA C22.1, Canadian Electrical Code. In all other countries, you must install the equipment in accordance with any regional or national electrical wiring codes, such as the International Electrotechnical Commission (IEC) Code 364, parts 1 through 7. Furthermore, you must be sure that all power distribution devices used in the installation, such as branch wiring and receptacles, are listed or certified grounding-type devices.

Because of the high ground-leakage currents associated with multiple servers connected to the same power source, Hewlett Packard Enterprise recommends the use of a PDU that is either permanently wired to the building's branch circuit or includes a nondetachable cord that is wired to an industrial-style plug. NEMA locking-style plugs or those complying with IEC 60309 are considered suitable for this purpose. Using common power outlet strips for the server is not recommended.

## Server warnings and cautions

---

 **WARNING:** This server is heavy. To reduce the risk of personal injury or damage to the equipment:

- Observe local occupational health and safety requirements and guidelines for manual material handling.
- Get help to lift and stabilize the product during installation or removal, especially when the product is not fastened to the rails. Hewlett Packard Enterprise recommends that a minimum of two people are required for all rack server installations. If the server is installed higher than chest level, a third person may be required to help align the server.
- Use caution when installing the server in or removing the server from the rack; it is unstable when not fastened to the rails.

---

 **WARNING:** To reduce the risk of personal injury from hot surfaces, allow the drives and the internal system components to cool before touching them.

---

 **WARNING:** To reduce the risk of personal injury, electric shock, or damage to the equipment, remove the power cord to remove power from the server. The front panel Power On/Standby button does not completely shut off system power. Portions of the power supply and some internal circuitry remain active until AC/DC power is removed.

---



**WARNING:** To reduce the risk of fire or burns after removing the energy pack:

- Do not disassemble, crush, or puncture the energy pack.
- Do not short external contacts.
- Do not dispose of the energy pack in fire or water.

After power is disconnected, battery voltage might still be present for 1s to 160s.

**AVERTISSEMENT:** Pour réduire les risques d'incendie ou de brûlures après le retrait du module batterie :

- N'essayez pas de démonter, d'écraser ou de percer le module batterie.
- Ne court-circuitiez pas ses contacts externes.
- Ne jetez pas le module batterie dans le feu ou dans l'eau.

Après avoir déconnecté l'alimentation, une tension peut subsister dans la batterie durant 1 à 160 secondes.

---



**CAUTION:** Protect the server from power fluctuations and temporary interruptions with a regulating uninterruptible power supply. This device protects the hardware from damage caused by power surges and voltage spikes and keeps the system in operation during a power failure.

---



**CAUTION:** Do not operate the server for long periods with the access panel open or removed. Operating the server in this manner results in improper airflow and improper cooling that can lead to thermal damage.

---

## Rack warnings

---



**WARNING:** To reduce the risk of personal injury or damage to the equipment, be sure that:

- The leveling jacks are extended to the floor.
  - The full weight of the rack rests on the leveling jacks.
  - The stabilizing feet are attached to the rack if it is a single-rack installation.
  - The racks are coupled together in multiple-rack installations.
  - Only one component is extended at a time. A rack may become unstable if more than one component is extended for any reason.
- 



**WARNING:** To reduce the risk of personal injury or equipment damage when unloading a rack:

- At least two people are needed to safely unload the rack from the pallet. An empty 42U rack can weigh as much as 115 kg (253 lb), can stand more than 2.1 m (7 ft) tall, and might become unstable when being moved on its casters.
  - Never stand in front of the rack when it is rolling down the ramp from the pallet. Always handle the rack from both sides.
- 



**WARNING:** To reduce the risk of personal injury or damage to the equipment, adequately stabilize the rack before extending a component outside the rack. Extend only one component at a time. A rack may become unstable if more than one component is extended.

---



**WARNING:** When installing a server in a telco rack, be sure that the rack frame is adequately secured at the top and bottom to the building structure.

---

## Electrostatic discharge

Be aware of the precautions you must follow when setting up the system or handling components. A discharge of static electricity from a finger or other conductor may damage system boards or other static-sensitive devices. This type of damage may reduce the life expectancy of the system or component.

To prevent electrostatic damage:

- Avoid hand contact by transporting and storing products in static-safe containers.
- Keep electrostatic-sensitive parts in their containers until they arrive at static-free workstations.
- Place parts on a grounded surface before removing them from their containers.
- Avoid touching pins, leads, or circuitry.
- Always be properly grounded when touching a static-sensitive component or assembly. Use one or more of the following methods when handling or installing electrostatic-sensitive parts:
  - Use a wrist strap connected by a ground cord to a grounded workstation or computer chassis. Wrist straps are flexible straps with a minimum of 1 megohm  $\pm 10$  percent resistance in the ground cords. To provide proper ground, wear the strap snug against the skin.
  - Use heel straps, toe straps, or boot straps at standing workstations. Wear the straps on both feet when standing on conductive floors or dissipating floor mats.
  - Use conductive field service tools.
  - Use a portable field service kit with a folding static-dissipating work mat.

If you do not have any of the suggested equipment for proper grounding, have an authorized reseller install the part.

For more information on static electricity or assistance with product installation, contact an authorized reseller.

## Installing the server into the rack

To install the server into a rack with square, round, or threaded holes, see the instructions that ship with the rack hardware kit.



**WARNING:** This server is heavy. To reduce the risk of personal injury or damage to the equipment:

- Observe local occupational health and safety requirements and guidelines for manual material handling.
- Get help to lift and stabilize the product during installation or removal, especially when the product is not fastened to the rails. Hewlett Packard Enterprise recommends that a minimum of two people are required for all rack server installations. A third person may be required to help align the server if the server is installed higher than chest level.
- Use caution when installing the server in or removing the server from the rack; it is unstable when not fastened to the rails.



**CAUTION:** Always plan the rack installation so that the heaviest item is on the bottom of the rack. Install the heaviest item first, and continue to populate the rack from the bottom to the top.

---

## Procedure

### 1. Install the rack rail option.

For more information, see the installation instructions that ship with the selected rail system.

### 2. Install the server into the rack:

- a. Align the inner rail of the server with the outer rail.
- b. Slide the server into the rack until the quick-release latches engage with the front columns of the rack.

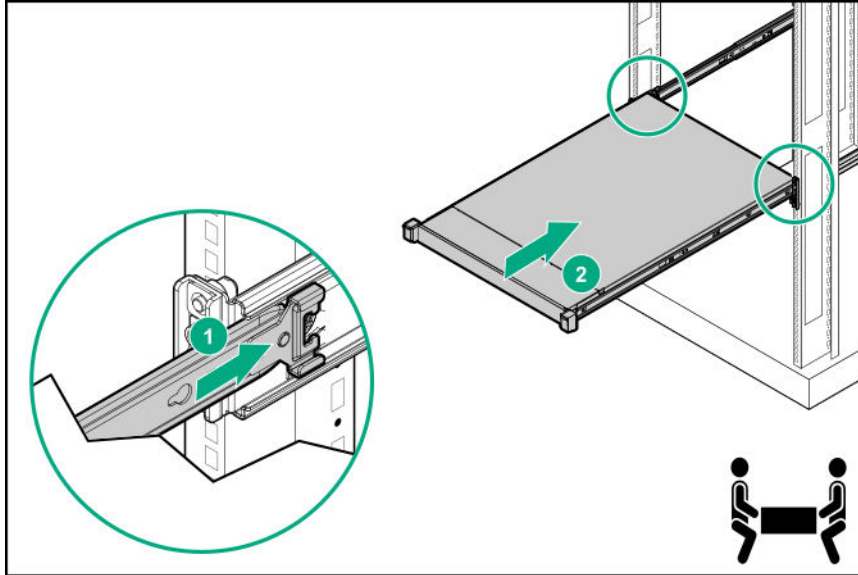

### c. Open the latches and tighten the shipping screws, if necessary.

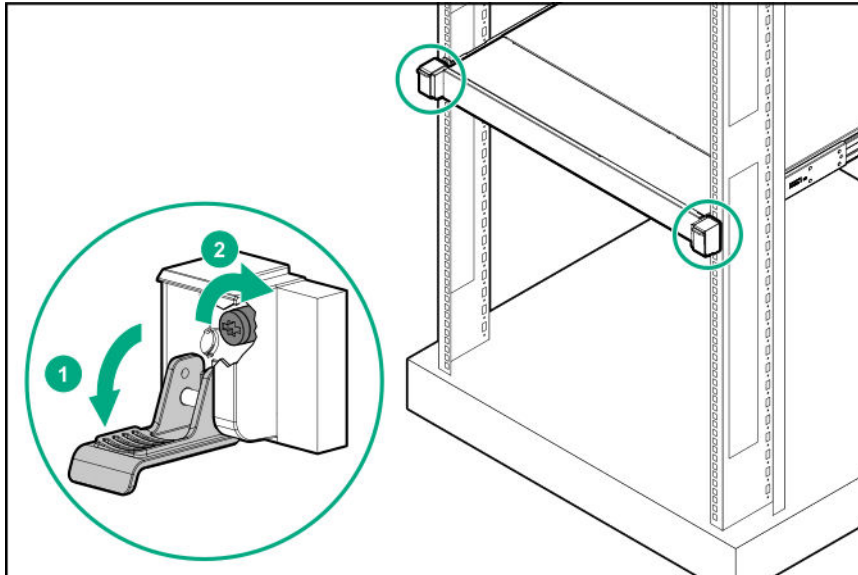

### 3. Install the cable management arm into the rack.

For more information, see the installation instructions that ship with the option.

### 4. Connect peripheral devices to the server.

For information on identifying connectors, see **Rear panel components** on page 12.

5. Connect the power cord to the rear of the server.
6. Use the hook-and-loop strap to secure the power cord.
7. Connect the power cord to the power source.

## POST screen options

When the server is powered on, the POST screen is displayed. The following options are displayed:

- **System Utilities (F9)**  
Use this option to configure the system BIOS.
- **Intelligent Provisioning (F10)**  
Use this option to deploy an operating system or configure storage.
- **Boot order (F11)**  
Use this option to make a one-time boot selection.
- **Network boot (F12)**  
Use this option to boot the server from the network.

## Operating system

This ProLiant server does not ship with provisioning media. Everything required to manage and install the system software and firmware is preloaded on the server.

To operate properly, the server must have a supported operating system. Attempting to run an unsupported operating system can cause serious and unpredictable results. For the latest information on operating system support, see the [\*\*Hewlett Packard Enterprise website\*\*](#).

Failure to observe UEFI requirements for ProLiant Gen10 servers can result in errors installing the operating system, failure to recognize boot media, and other boot failures. For more information on these requirements, see the *HPE UEFI Requirements* on the [\*\*Hewlett Packard Enterprise website\*\*](#).

To install an operating system on the server, use one of the following methods:

- Intelligent Provisioning—For single-server deployment, updating, and provisioning capabilities. For more information, see [\*\*Installing the operating system with Intelligent Provisioning\*\*](#) on page 54.
- Insight Control server provisioning—For multiserver remote OS deployment, use Insight Control server provisioning for an automated solution. For more information, see the Insight Control documentation on the [\*\*Hewlett Packard Enterprise website\*\*](#).

For additional system software and firmware updates, download the Service Pack for ProLiant from the [\*\*Hewlett Packard Enterprise website\*\*](#). Software and firmware must be updated before using the server for the first time, unless any installed software or components require an older version.

For more information, see [\*\*Keeping the system current\*\*](#) on page 129.

For more information on using these installation methods, see the [\*\*Hewlett Packard Enterprise website\*\*](#).

## Installing the operating system with Intelligent Provisioning

### Procedure

1. Connect the Ethernet cable between the network connector on the server and a network jack.
2. Press the Power On/Standby button.
3. During server POST, press **F10**.
4. Complete the initial Preferences and Registration portion of **Intelligent Provisioning**.
5. At the 1 Start screen, click **Configure and Install**.
6. To finish the installation, follow the onscreen prompts. An Internet connection is required to update the firmware and systems software.

## Installing or deploying an operating system

Before installing an operating system, observe the following:

- Be sure to read the HPE UEFI requirements for ProLiant servers on the **Hewlett Packard Enterprise website**. If UEFI requirements are not met, you might experience boot failures or other errors when installing the operating system.
- Update firmware before using the server for the first time, unless software or components require an older version. For more information, see "**Keeping the system current** on page 129."
- For the latest information on supported operating systems, see the **Hewlett Packard Enterprise website**.
- The server does not ship with OS media. All system software and firmware is preloaded on the server.

# Hardware options installation

This chapter provides detailed instructions on how to install hardware options.

For more information on supported options, see the product QuickSpecs on the HPE ProLiant DL325 Gen10 Server website at:

<http://www.hpe.com/servers/dl325-gen10>

To view the warranty for your server and supported options, see **Warranty information** on page 138.

## Introduction

Install any hardware options before initializing the server. For options installation information, see the option documentation. For server-specific information, use the procedures in this section.

If multiple options are being installed, read the installation instructions for all the hardware options to identify similar steps and streamline the installation process.



**WARNING:** To reduce the risk of personal injury from hot surfaces, allow the drives and the internal system components to cool before touching them.

---



**CAUTION:** To prevent damage to electrical components, properly ground the server before beginning any installation procedure. Improper grounding can cause electrostatic discharge.

---

## Drive options

This server supports up to 4 hot-plug LFF, 10 hot-plug SFF SAS/SATA, or 10 NVMe drives.

The embedded HPE Smart Array S100i SR Gen10 Controller supports SATA drives. For SAS support, install a Smart Array Gen10 modular or PCIe plug-in controller option.

In 8SFF NVMe configuration, Smart Array PCIe plug-in controller is not supported.

## Drive installation guidelines

When adding drives to the server, observe the following general guidelines:

- The system automatically sets all device numbers.
- Populate drive bays, based on the drive numbering sequence. Start from the drive bay with the lowest device number.
- All drives grouped into the same drive array must meet the following criteria:
  - They must be either all SAS or all SATA.
  - They must be either all hard drives or all solid state drives.
  - Drives should be the same capacity to provide the greatest storage space efficiency when drives are grouped together into the same drive array.

## Installing a hot-plug drive



**CAUTION:** To prevent improper cooling and thermal damage, do not operate the server unless all bays are populated with either a component or a blank.

---

## Procedure

1. If installed, **remove the bezel.**
2. Remove the drive blank.
  - LFF drive

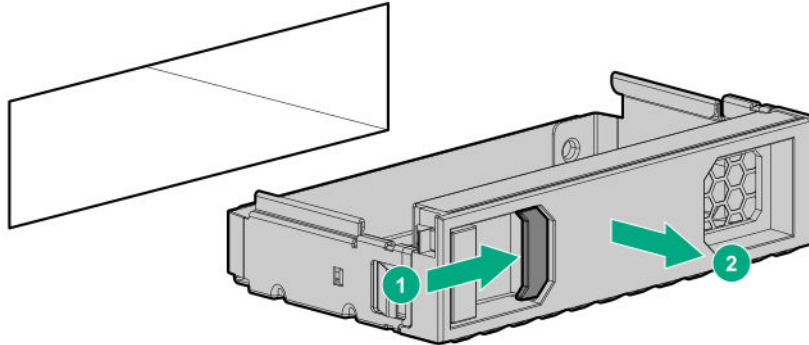

- SFF drive

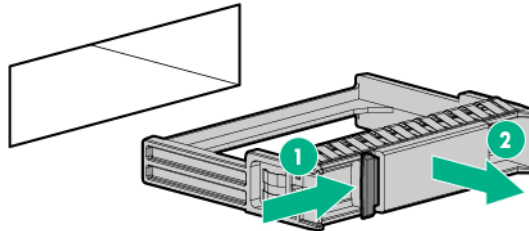

3. Prepare the drive.

- LFF drive

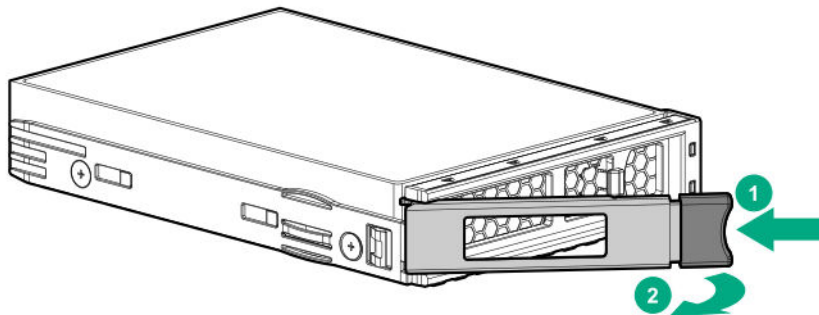

- SFF SAS/SATA drive



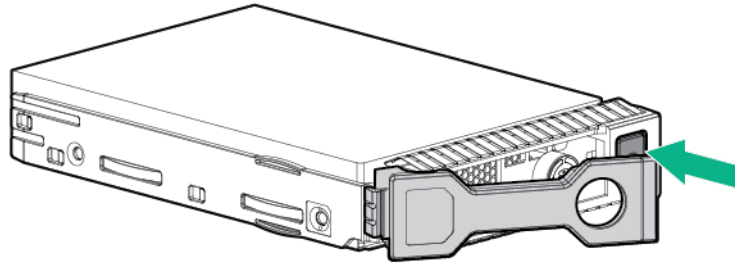

- NVMe drive

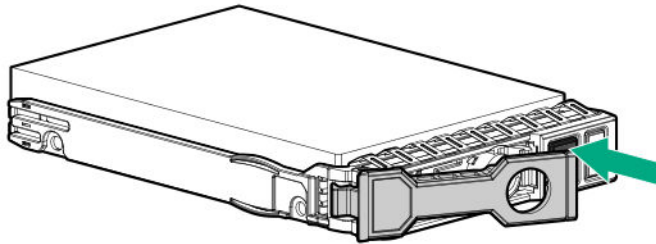

**4.** Install the drive.

- LFF drive

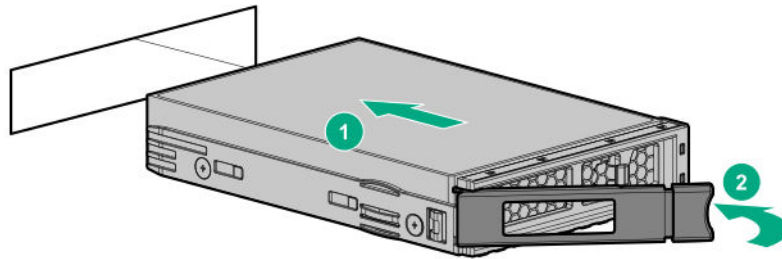

- SFF SAS/SATA drive

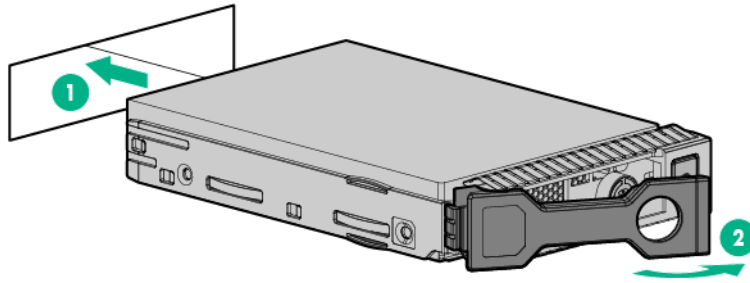

- NVMe drive

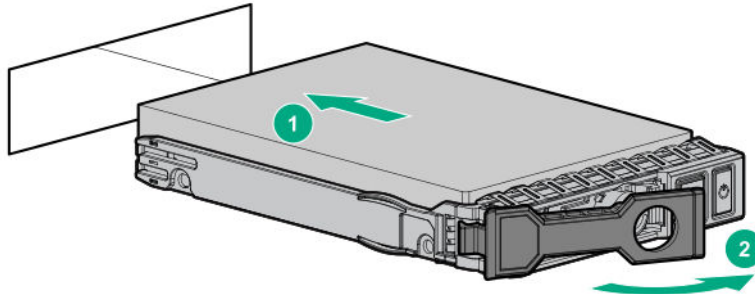

5. Determine the status of the drive from the **drive LED definitions**.

6. If removed, **install the bezel**.

The installation is complete.

To configure arrays, see the *HPE Smart Array SR Gen10 Configuration Guide* at the **Hewlett Packard Enterprise website**.

## Drive cage options

### Installing the 2SFF SAS/SATA drive cage

#### Prerequisites

Before you perform this procedure, make sure that you have a T-10 Torx screwdriver available.

#### Procedure

1. If installed, **remove the bezel**.
2. **Power down the server**.
3. Remove all power:
  - a. Disconnect each power cord from the power source.
  - b. Disconnect each power cord from the server.
4. Disconnect all peripheral cables from the server.
5. Do one of the following:

- **Extend the server from the rack.**
  - **Remove the server from the rack.**
6. **Remove the access panel.**
  7. **Remove the media bay blank.**
  8. Install the 2SFF SAS/SATA drive cage assembly.

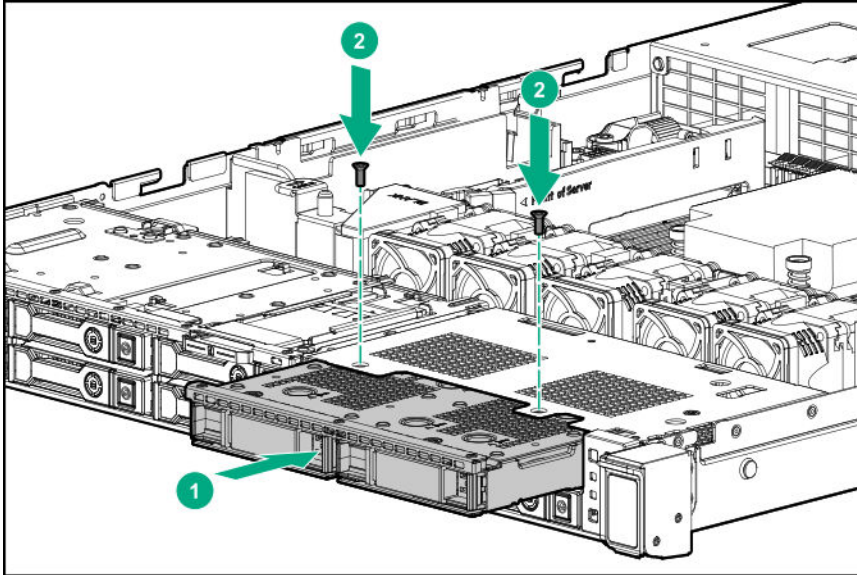

9. Do one of the following:
  - For the connection to system board  
If installed, **remove the air baffle.**
  - For the connection to a type-a controller  
If installed, remove the controller to secure the space for cabling.
10. **Connect the signal and power cables for the 2SFF SAS/SATA drive cage.**
11. Do one of the following:
  - If removed, **install the air baffle.**
  - If removed, **install the type-a controller.**
12. **Install the SFF drive.**
13. **Install the access panel.**
14. **Install the server into the rack.**
15. Connect all peripheral cables to the server.
16. Connect each power cord to the server.
17. Connect each power cord to the power source.

**18. Power up the server.**

**19. If removed, install the bezel.**

The installation is complete.

## Installing the 2SFF NVMe drive cage

### Prerequisites

Before you perform this procedure, make sure that you have a T-10 Torx screwdriver available.

### Procedure

- 1.** If installed, **remove the bezel.**
- 2. Power down the server.**
- 3.** Remove all power:
  - a.** Disconnect each power cord from the power source.
  - b.** Disconnect each power cord from the server.
- 4.** Disconnect all peripheral cables from the server.
- 5.** Do one of the following:
  - **Extend the server from the rack.**
  - **Remove the server from the rack.**
- 6. Remove the access panel.**
- 7. Remove the media bay blank.**
- 8.** Install the 2SFF NVMe drive cage assembly.

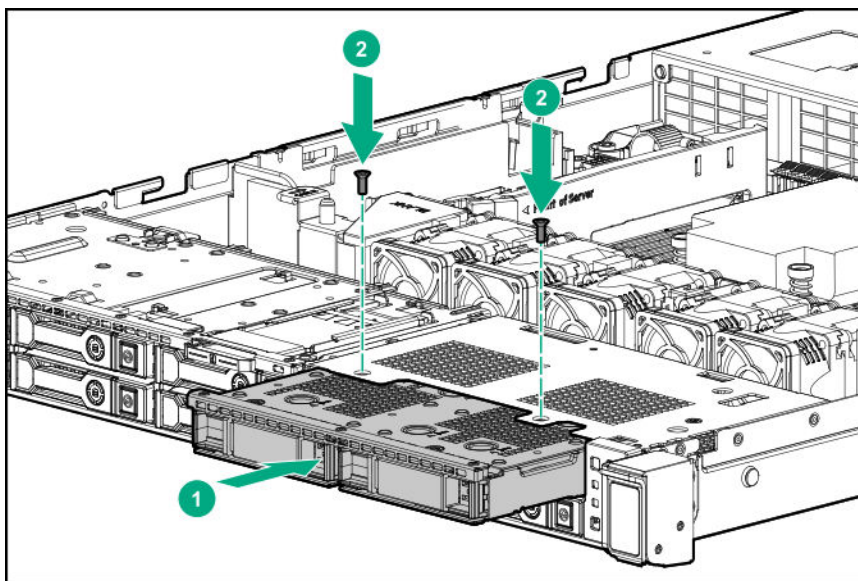

- 9. Connect the signal and power cables for the 2SFF NVMe drive cage.**

- 10. Install the NVMe drive.**
- 11. Install the access panel.**
- 12. Install the server into the rack.**
- 13.** Connect all peripheral cables to the server.
- 14.** Connect each power cord to the server.
- 15.** Connect each power cord to the power source.
- 16. Power up the server.**
- 17.** If removed, **install the bezel.**

The installation is complete.

## Storage controller options

This server supports the following storage controllers:

- For SATA drives only – Embedded HPE Smart Array S100i SR Gen10 controller
- For SAS and SATA drives:
  - Smart Array type-a modular controller
  - Smart Array PCIe plug-in controllerIn 8SFF NVMe configuration, Smart Array PCIe plug-in controller is not supported.

## Installing a Smart Array type-a modular controller

Secondary riser slot 3 is not available when a Smart Array type-a module controller is installed in the system.

### Prerequisites

- Before you perform this procedure, make sure that you have the following items available:
  - Smart Array modular controller option
  - Compatible controller cable option
  - T-15 Torx screwdriver
- If you are installing a Smart Array P-class Gen10 controller, **an energy pack option is required.**

Before you perform this procedure, perform the following steps:

- 1.** Back up data on the system.
- 2.** Close all applications.
- 3. Update the server firmware if it is not the latest revision.**
- 4.** Do one of the following:

- If the new Smart Array is the new boot device, install the device drivers.
  - If the new Smart Array is not the new boot device, go to the next step.
5. Ensure that users are logged off and that all tasks are completed on the server.



**CAUTION:** In systems that use external data storage, be sure that the server is the first unit to be powered down and the last to be powered back up. Taking this precaution ensures that the system does not erroneously mark the drives as failed when the server is powered up.

---

### Procedure

1. **Power down the server.**
2. Remove all power:
  - a. Disconnect each power cord from the power source.
  - b. Disconnect each power cord from the server.
3. Disconnect all peripheral cables from the server.
4. Do one of the following:
  - **Extend the server from the rack.**
  - **Remove the server from the rack.**
5. **Remove the access panel.**
6. If installed, **remove the Smart Array PCIe plug-in controller from slot 3 of the secondary riser cage.**
7. Install a Smart Array type-a modular controller into Smart Array modular controller connector:
  - a. While holding the snap-in latch in the open position, tilt the controller board down until the holes on the controller board are inserted through the alignment pins on the system board.
  - b. Release the snap-in latch and make sure that it properly engages over the side of the controller board.
  - c. Press on the area of the controller board marked as PRESS TO INSTALL to ensure that the board is firmly seated on the slot.
  - d. Tighten the controller board thumbscrews.

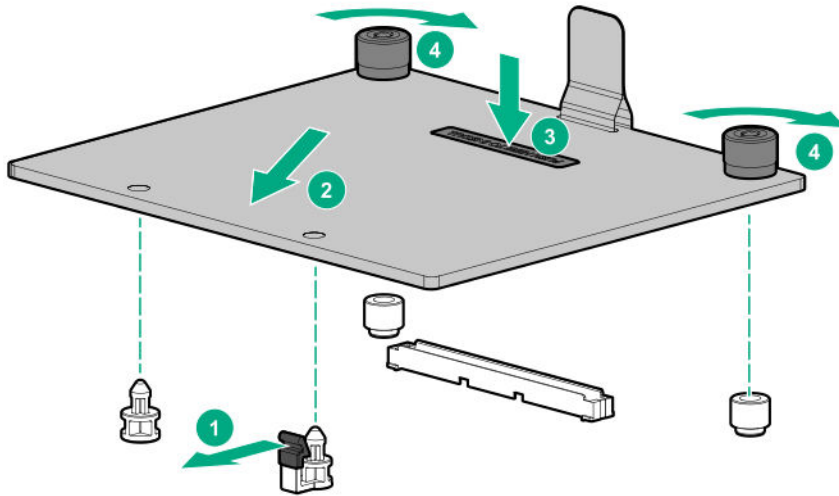

**8. Cable the controller.**

**9.** To enable HPE Smart Array SR SmartCache in a Smart Array P-class Gen10 controller, **install the energy pack.**

SmartCache and CacheCade enable solid-state drives to be used as caching devices for hard drive media. These features accelerate access to frequently used data by caching hot data from the hard drives onto the solid-state drives.

**10. Install the access panel.**

**11. Install the server into the rack.**

**12.** Connect all peripheral cables to the server.

**13.** Connect each power cord to the server.

**14.** Connect each power cord to the power source.

**15. Power up the server.**

**16. Configure the storage controller.**

The installation is complete.

## Installing a Smart Array PCIe plug-in controller

### Prerequisites

- Before you perform this procedure, make sure that you have the following items available:
  - Smart Array PCIe plug-in controller option
  - Compatible controller cable option
  - T-15 Torx screwdriver
- If you are installing a Smart Array P-class Gen10 controller, **an energy pack option is required.**

Before you perform this procedure, perform the following steps:

- 1.** Back up data on the system.
- 2.** Close all applications.

**3. Update the server firmware if it is not the latest revision.**

**4.** Do one of the following:

- If the new Smart Array is the new boot device, install the device drivers.
- If the new Smart Array is not the new boot device, go to the next step.

**5.** Ensure that users are logged off and that all tasks are completed on the server.

---

**⚠ CAUTION:** In systems that use external data storage, be sure that the server is the first unit to be powered down and the last to be powered back up. Taking this precaution ensures that the system does not erroneously mark the drives as failed when the server is powered up.

---

**Procedure**

**1. Power down the server.**

**2.** Remove all power:

- a. Disconnect each power cord from the power source.
- b. Disconnect each power cord from the server.

**3.** Disconnect all peripheral cables from the server.

**4.** Do one of the following:

- **Extend the server from the rack.**
- **Remove the server from the rack.**

**5. Remove the access panel.**

**6.** If installing a PCIe plug-in controller in the primary riser:

- a. **Remove the primary riser cage.**
- b. **Remove the primary riser blank.**
- c. Install the controller.
  - Primary riser slot 1



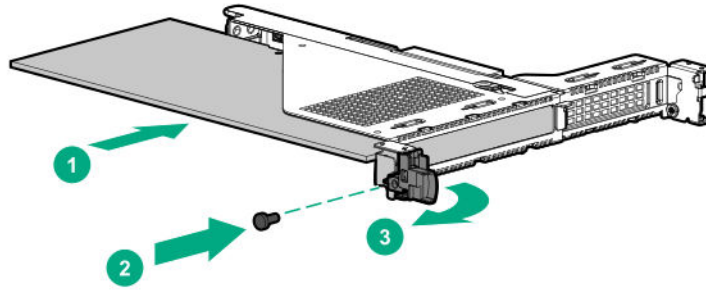

- Primary riser slot 2

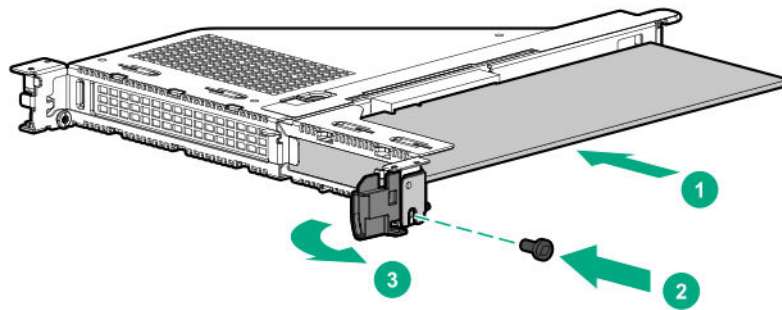

**d. Install the primary riser cage**

**7.** If installing a PCIe plug-in controller in the secondary riser:

**a.** If installed, **remove the Smart Array type-a modular controller.**

**b.** Do one of the following:

- **Remove the serial port.**
- **Remove the secondary riser blank.**

**c. Install the secondary riser.**

**d.** Install the controller.

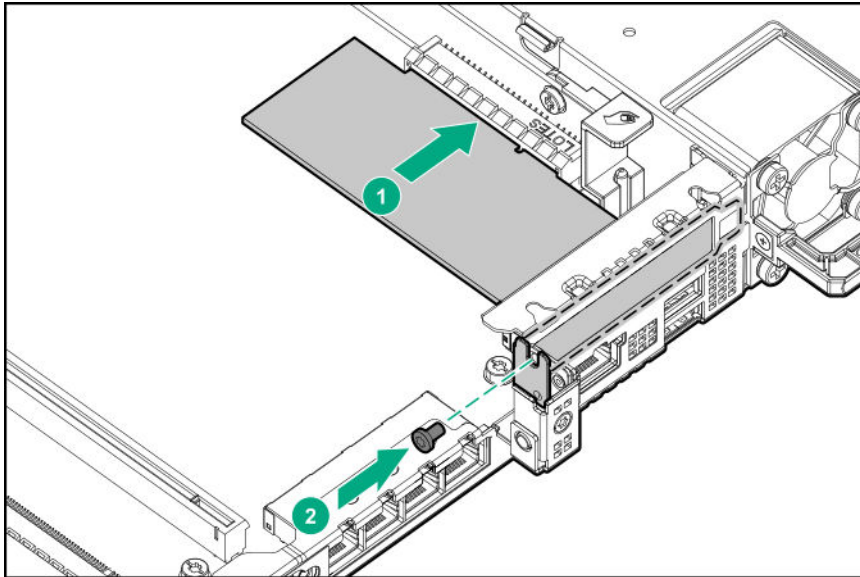

**8. Cable the controller.**

- 9.** To enable HPE Smart Array SR SmartCache in a Smart Array P-class Gen10 controller, **install the energy pack.** SmartCache and CacheCade enable solid-state drives to be used as caching devices for hard drive media. These features accelerate access to frequently used data by caching hot data from the hard drives onto the solid-state drives.

**10. Install the access panel.**

**11. Install the server into the rack.**

- 12.** Connect all peripheral cables to the server.
- 13.** Connect each power cord to the server.
- 14.** Connect each power cord to the power source.
- 15. Power up the server.**
- 16. Configure the storage controller.**

The installation is complete.

## Configuring an HPE Smart Array Gen10 controller

### Procedure

- 1. Power up the server.**
- 2.** If you are running the server in UEFI Boot Mode, select the boot options.
- 3. Update the drive firmware if it is not the latest revision.**
- 4.** (Optional) If running the server in Legacy Boot Mode, set the controller as the boot controller.
- 5.** (Optional) If running the server in Legacy Boot Mode, change the controller boot order.
- 6.** If the new controller is not the new boot device, install the device drivers.

7. If the controller firmware is not the latest version, use SPP to update it.
8. Use UEFI System Utilities or HPE Smart Storage Administrator (HPE SSA) to create arrays and logical drives.

See the following resources for more information:

- SPP – See the product documentation in the information library:  
<http://www.hpe.com/info/spp/docs>
- UEFI System Utilities or HPE Smart Storage Administrator – See the *HPE Smart Array SR Gen10 Configuration Guide* in the information library:  
<http://www.hpe.com/info/smartstorage-docs>

## Expansion board options

The server has three PCIe 3 expansion slots that support different form factor expansion boards. For more information on the PCIe slot specifications, see [PCIe slot description](#) on page 24.

### Installing an expansion board

Secondary riser slot 3 is not available when a Smart Array type-a module controller is installed in the system.

#### Prerequisites

Before you perform this procedure, make sure that you have the following items available:

- Expansion board option kit
- Internal and external cabling required by the expansion board
- T-15 Torx screwdriver

#### Procedure

1. **Power down the server.**
2. Remove all power:
  - a. Disconnect each power cord from the power source.
  - b. Disconnect each power cord from the server.
3. Disconnect all peripheral cables from the server.
4. Do one of the following:
  - **Extend the server from the rack.**
  - **Remove the server from the rack.**
5. **Remove the access panel.**
6. **Identify the PCIe slot compatible with the expansion board option.**
7. If installing the expansion board in the primary riser:

- a. **Remove the primary riser cage.**
- b. **Remove the primary riser blank.**
- c. Install the expansion board.
  - Primary riser slot 1

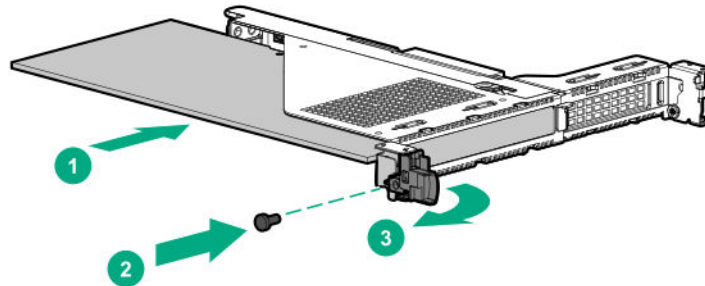

- Primary riser slot 2

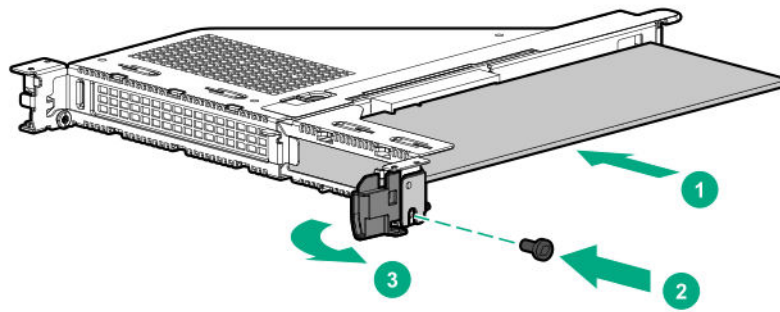

- d. **Install the primary riser cage.**

8. If installing an expansion board in the secondary riser:
  - a. If installed, **remove the Smart Array type-a modular controller.**
  - b. Do one of the following:
    - **Remove the serial port.**
    - **Remove the secondary riser blank.**

c. **Install the secondary riser.**

d. Install the controller.

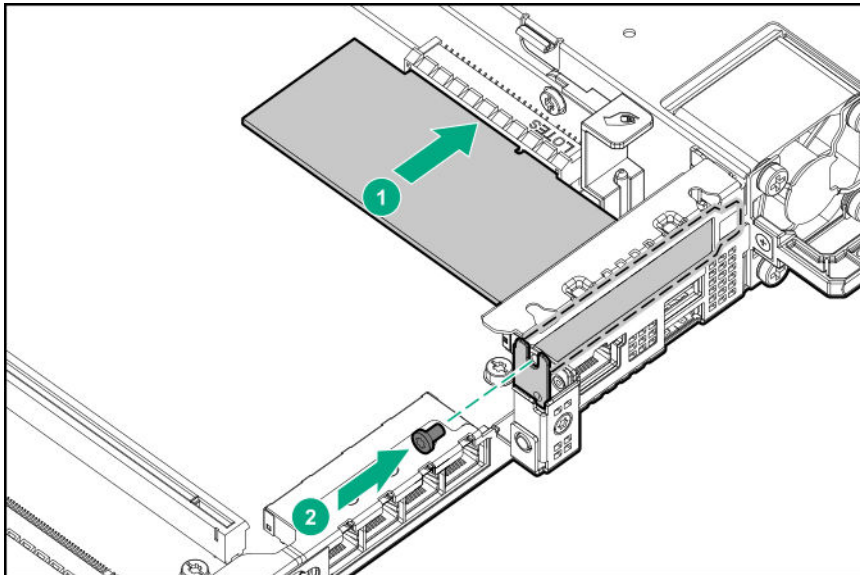

9. Connect all necessary internal cabling to the expansion board.

For more information on these cabling requirements, see the documentation that ships with the option.

10. **Install the access panel.**

11. **Install the server into the rack.**

12. Connect all necessary external cabling to the expansion board.

For more information on these cabling requirements, see the documentation that ships with the option.

13. Connect all peripheral cables to the server.

14. Connect each power cord to the server.

15. Connect each power cord to the power source.

16. **Power up the server.**

The installation is complete.

## Installing the GPU

### Prerequisites

- Before you perform this procedure, make sure that you have the following items available:
  - GPU enablement option
  - T-15 Torx screwdriver
- Before you perform this procedure, **make sure that the fan in the fan bay 7 is installed.**

## Procedure

1. **Power down the server.**
2. Remove all power:
  - a. Disconnect each power cord from the power source.
  - b. Disconnect each power cord from the server.
3. Disconnect all peripheral cables from the server.
4. Do one of the following:
  - **Extend the server from the rack.**
  - **Remove the server from the rack.**
5. **Remove the access panel.**
6. Place the GPU holder to be engaged with the spool on the chassis.

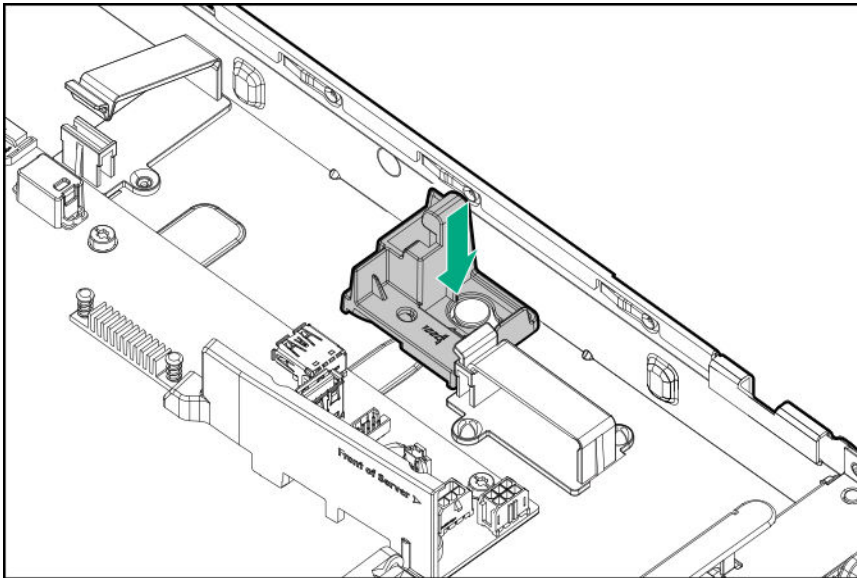

7. **Remove the primary riser cage.**
8. **Remove the primary riser slot 1 blank.**
9. Install the GPU into the primary riser slot 1.

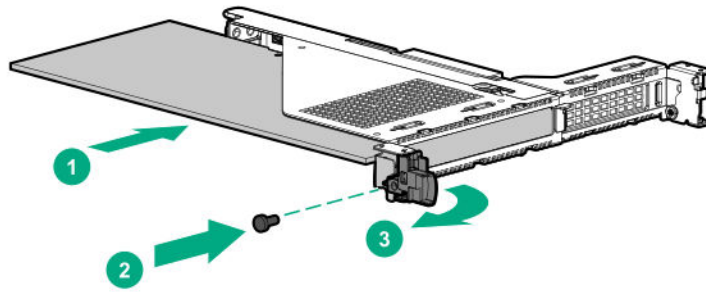

**10. Install the primary riser cage.**

**11. Secure the GPU.**

- a. Slide the GPU holder until it is stuck by the spool on the chassis and engage the holder to the GPU bracket.
- b. Install the screw.

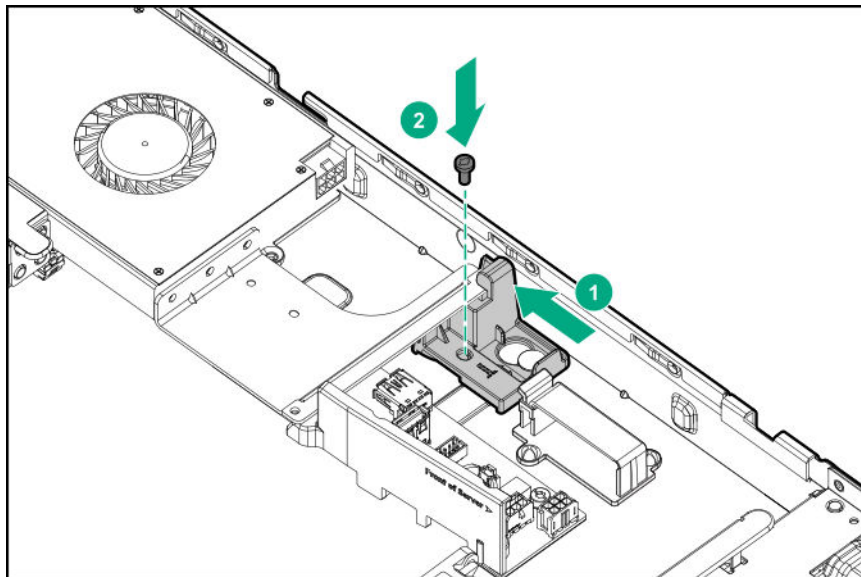

**12. Connect the GPU power cable.**

**13. Install the access panel.**

**14. Install the server into the rack.**

- 15. Connect all peripheral cables to the server.
- 16. Connect each power cord to the server.
- 17. Connect each power cord to the power source.
- 18. **Power up the server.**

The installation is complete.

# Energy pack options

Hewlett Packard Enterprise offers two centralized backup power source options to back up write cache content on P-class Smart Array controllers in case of an unplanned server power outage.

- **HPE Smart Storage Battery**
- **HPE Smart Storage Hybrid Capacitor**

---

**!** **IMPORTANT:** The HPE Smart Storage Hybrid Capacitor is only supported on Gen10 and later servers that support the 96W HPE Smart Storage Battery.

---

One energy pack option can support multiple devices. An energy pack option is required for P-class Smart Array controllers. Once installed, the status of the energy pack displays in HPE iLO. For more information, see the HPE iLO user guide on the Hewlett Packard Enterprise website (<http://www.hpe.com/support/ilo-docs>).

## HPE Smart Storage Battery

The HPE Smart Storage Battery supports the following devices:

HPE Smart Array SR controllers

A single 96W battery can support up to 24 devices.

After the battery is installed, it might take up to two hours to charge. Controller features requiring backup power are not re-enabled until the battery is capable of supporting the backup power.

This server supports the 96W HPE Smart Storage Battery with the 145mm cable.

## HPE Smart Storage Hybrid Capacitor

The HPE Smart Storage Hybrid Capacitor supports the following devices:

HPE Smart Array SR controllers

The capacitor pack can support up to three devices.

This server supports the HPE Smart Storage Hybrid Capacitor with the 145mm cable.

Before installing the HPE Smart Storage Hybrid Capacitor, verify that the system BIOS meets the minimum firmware requirements to support the capacitor pack.

---

**!** **IMPORTANT:** If the system BIOS or controller firmware is older than the minimum recommended firmware versions, the capacitor pack will only support one device.

---

The capacitor pack is fully charged after the system boots.

## Minimum firmware versions

Product	Minimum firmware version
HPE ProLiant DL325 Gen10 Server system ROM	1.40
HPE Smart Array SR controllers	1.90



## Installing an energy pack

### Prerequisites

Before you perform this procedure:

- **Make sure that a Smart Array P-class controller is installed.**
- Make sure that you have the following items available:
  - Storage controller backup power cable (ships with the storage controller)
  - Energy pack option
- If you are installing the HPE Smart Storage Hybrid Capacitor, **verify that the server meets the minimum firmware version for the capacitor pack installation.**

### Procedure

1. **Power down the server.**
2. Remove all power:
  - a. Disconnect each power cord from the power source.
  - b. Disconnect each power cord from the server.
3. Disconnect all peripheral cables from the server.
4. Do one of the following:
  - **Extend the server from the rack.**
  - **Remove the server from the rack.**
5. **Remove the access panel.**
6. Install the energy pack.

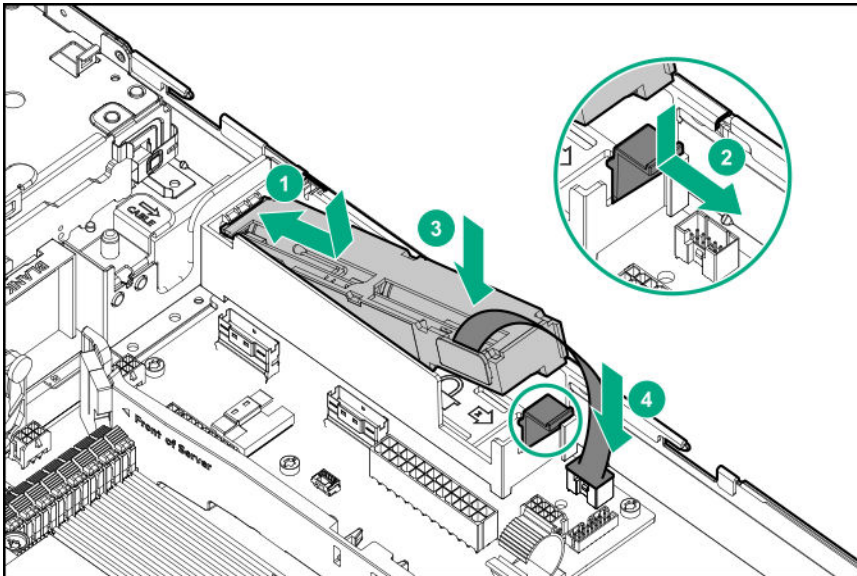

7. **Connect the controller backup power cable.**

8. **Install the access panel.**
9. **Install the server into the rack.**
10. Connect all peripheral cables to the server.
11. Connect each power cord to the server.
12. Connect each power cord to the power source.
13. **Power up the server.**

The installation is complete.

## Installing the M.2 SSD enablement option

### Prerequisites

Before you perform this procedure, make sure that you have the following items available:

- T-15 Torx screwdriver
- Phillips No. 1 screwdriver

### Procedure

1. **Power down the server.**
2. Remove all power:
  - a. Disconnect each power cord from the power source.
  - b. Disconnect each power cord from the server.
3. Disconnect all peripheral cables from the server.
4. Do one of the following:
  - **Extend the server from the rack.**
  - **Remove the server from the rack.**
5. **Remove the access panel.**
6. **Remove the riser cage.**
7. **Remove the riser blank.**
8. Install the SSD module on the M.2 SSD enablement board:
  - a. Insert the SSD module into the SSD slot at a 45 degree angle, and then gently press it down against the M.2 SSD Enablement board.
  - b. Secure the SSD module to the M.2 SSD enablement board with a screw.
  - c. To install a second SSD module, repeat the process.

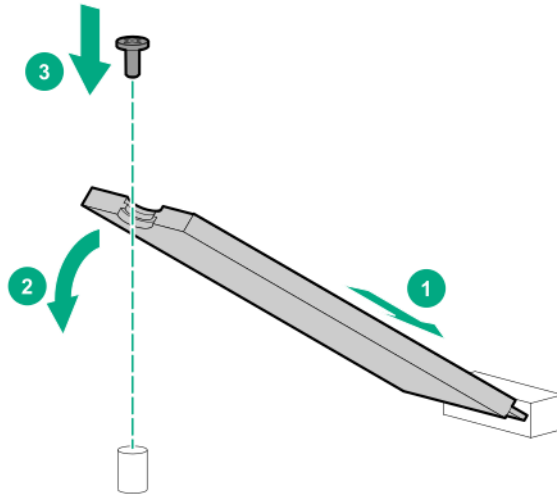

9. **Install the M.2 SSD enablement board.**
10. **Install the riser cage.**
11. **Connect the SATA cables.**
12. **Install the access panel.**
13. **Install the server into the rack.**
14. Connect all peripheral cables to the server.
15. Connect each power cord to the server.
16. Connect each power cord to the power source.
17. **Power up the server.**

The installation is complete.

## ODD options

### Installing the ODD in LFF

#### Procedure

1. If installed, **remove the bezel.**
2. **Power down the server.**
3. Remove all power:
  - a. Disconnect each power cord from the power source.
  - b. Disconnect each power cord from the server.
4. Disconnect all peripheral cables from the server.
5. Do one of the following:

- **Extend the server from the rack.**
- **Remove the server from the rack.**

**6. Remove the access panel.**

7. Remove the ODD bay blank.

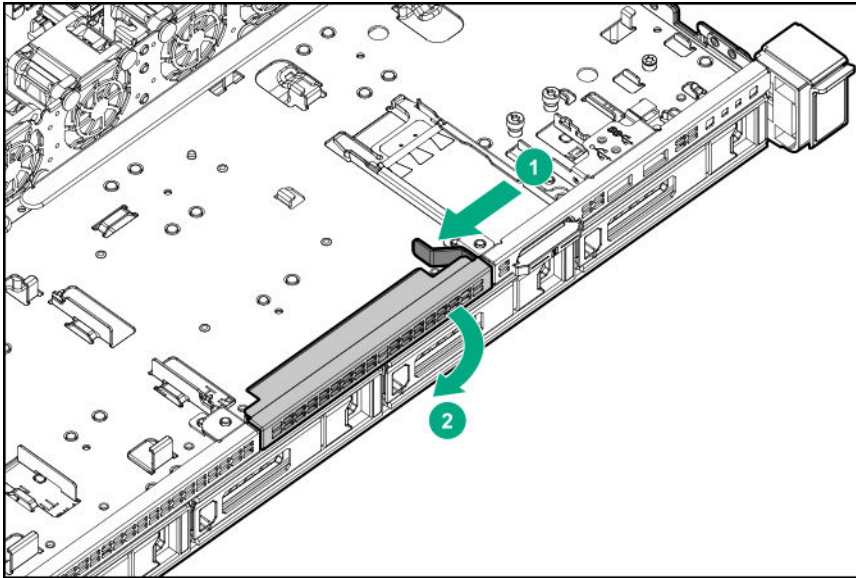

8. Install the ODD in the cage.

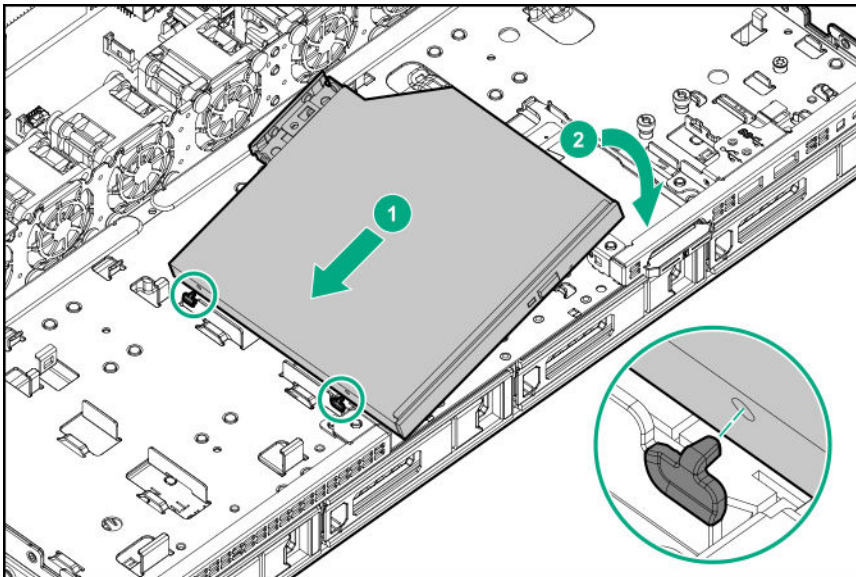

9. **Cable the ODD.**

10. **Install the access panel.**

11. **Install the server into the rack.**

12. Connect all peripheral cables to the server.
13. Connect each power cord to the server.
14. Connect each power cord to the power source.

**15. Power up the server.**

**16.** If removed, **install the bezel.**

The installation is complete.

## Installing the ODD in SFF

### Prerequisites

Before you perform this procedure, make sure that you have a T-10 Torx screwdriver available.

### Procedure

**1. Power down the server.**

**2.** Remove all power:

- a. Disconnect each power cord from the power source.
- b. Disconnect each power cord from the server.

**3.** Disconnect all peripheral cables from the server.

**4.** Do one of the following:

- **Extend the server from the rack.**
- **Remove the server from the rack.**

**5. Remove the access panel.**

**6. Remove the media bay blank.**

**7.** Remove the ODD cage blank.

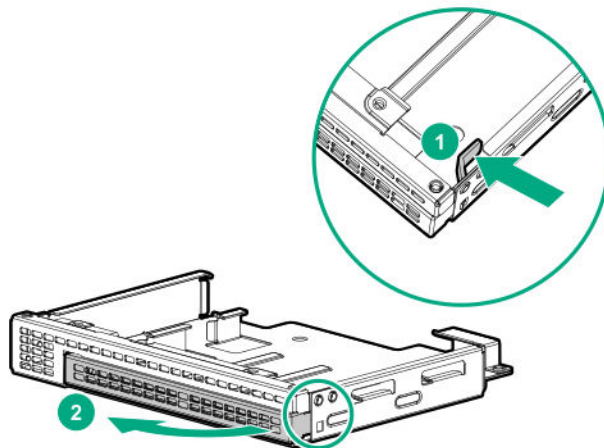

**8.** Install the ODD into the cage.

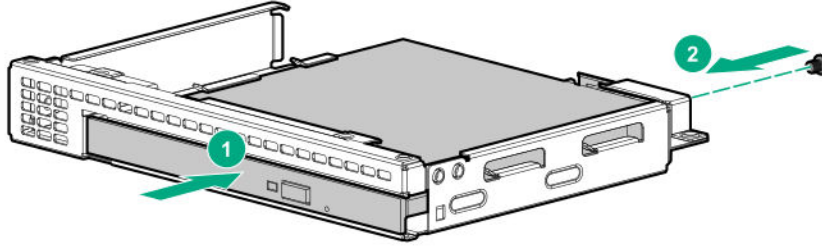

9. Install the ODD cage assembly.

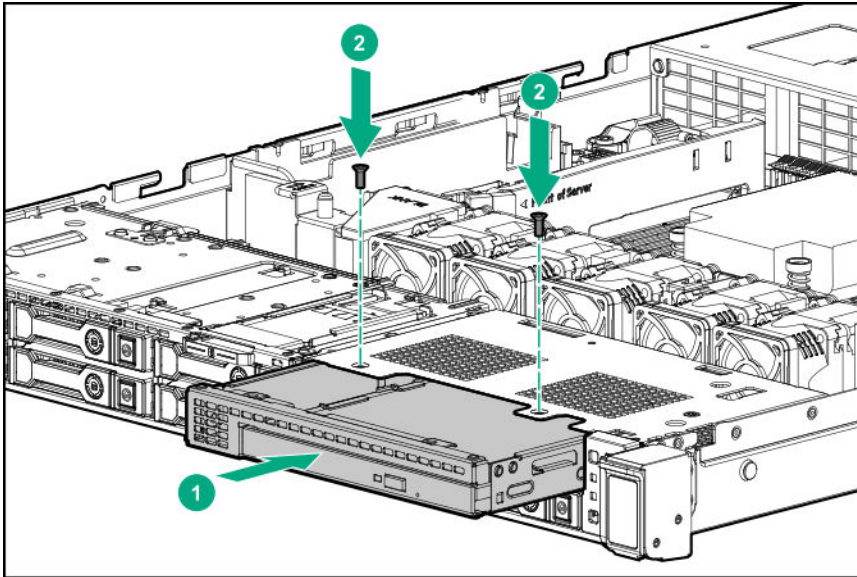

10. **Connect the ODD cable.**
11. **Install the access panel.**
12. **Install the server into the rack.**
13. Connect all peripheral cables to the server.
14. Connect each power cord to the server.
15. Connect each power cord to the power source.
16. **Power up the server.**

The installation is complete.

# Fan option

## Fan population

The number of fans installed in the server determines fan redundancy.

Configuration	Bay 1	Bay 2	Bay 3	Bay 4	Bay 5	Bay 6	Bay 7
4LFF <sup>1</sup>	Blank	Fan	Fan	Fan	Fan	Fan	Blank
8SFF SAS or SATA <sup>1</sup>	Blank	Fan	Fan	Fan	Fan	Fan	Blank
4LFF or 8SFF with a GPU installed	Blank	Fan	Fan	Fan	Fan	Fan	Fan
8SFF NVMe <sup>1</sup>	Fan	Fan	Fan	Fan	Fan	Fan	Fan

<sup>1</sup> This configuration supports fan redundancy.

## Fan mode behavior

- In nonredundant fan mode, a fan failure or a missing fan causes:
  - The system Health LED to flash amber.
  - The operating system to orderly shutdown.
- In redundant fan mode:
  - A fan rotor failure will switch the system to nonredundant fan mode.  
This change is indicated by the Health LED flashing amber. The system continues to operate normally in this mode.
  - A second fan rotor failure or a missing fan causes the operating system to orderly shutdown.

## Installing a fan

This server supports redundant fans to provide sufficient airflow to the system if a fan rotor fails.

 **WARNING:** To reduce the risk of personal injury from hot surfaces, allow the drives and the internal system components to cool before touching them.

 **CAUTION:** To prevent improper cooling and thermal damage, do not operate the server unless all bays are populated with either a component or a blank.

### Procedure

1. **Power down the server.**
2. Remove all power:

- a. Disconnect each power cord from the power source.
  - b. Disconnect each power cord from the server.
3. Disconnect all peripheral cables from the server.
4. Do one of the following:
  - **Extend the server from the rack.**
  - **Remove the server from the rack.**
5. **Remove the access panel.**
6. If installed, **remove the air baffle.**
7. To determine which fan blanks to remove to install the additional fans, see **Fan bay numbering.**
8. Remove the fan blank.
  - LFF

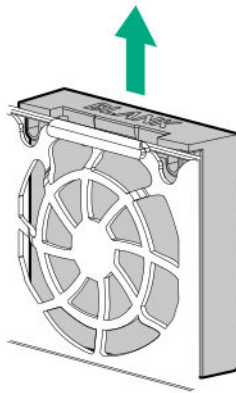

- SFF



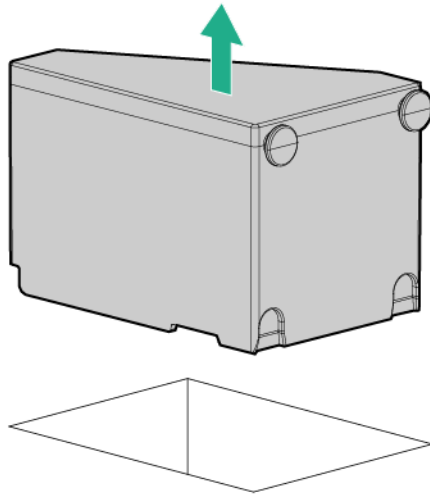

**9.** Install the fan.

- LFF

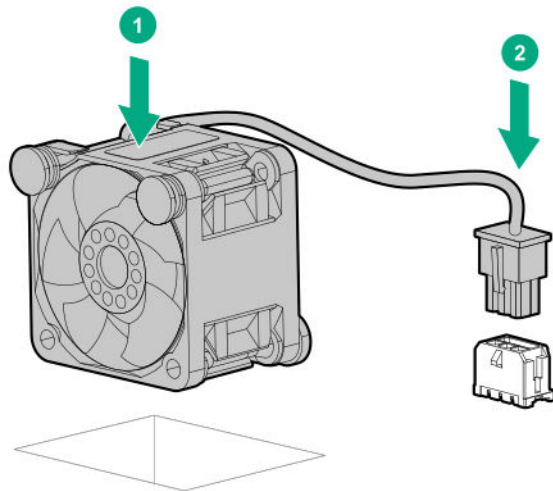

- SFF

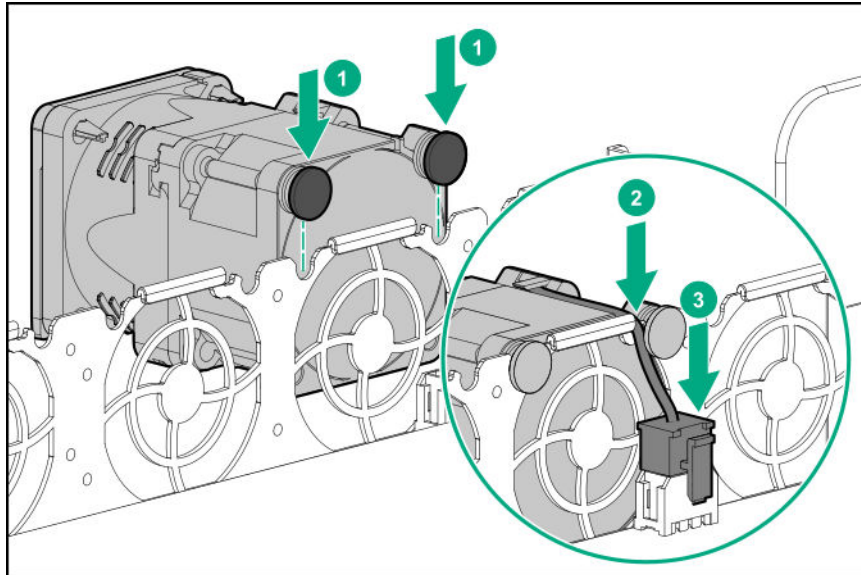

10. If removed, **install the air baffle.**
11. **Install the access panel.**
12. **Install the server into the rack.**
13. Connect all peripheral cables to the server.
14. Connect each power cord to the server.
15. Connect each power cord to the power source.
16. **Power up the server.**

The installation is complete.

## Memory options

- !** **IMPORTANT:** This server does not support mixing LRDIMMs and RDIMMs. Attempting to mix any combination of these DIMMs can cause the server to halt during BIOS initialization. All memory installed in the server must be of the same type.

### DIMM-processor compatibility

The installed processor determines the type of DIMM that is supported in the server:

- AMD EPYC 7x1 processors support DDR4-2666 DIMMs.
- AMD EPYC 7x2 processors support DDR4-2933 DIMMs.

Mixing DIMM types is not supported. Install only the supported DDR4-2666 or DDR4-2933 DIMMs in the server.

### DIMM population information

For specific DIMM population information, see the DIMM population guidelines on the Hewlett Packard Enterprise website (<http://www.hpe.com/docs/amd-population-rules>).

## Memory speed tables

For specific DDR4 server memory speeds, for HPE servers using AMD processors, see the Hewlett Packard Enterprise website (<http://www.hpe.com/docs/amd-speed-tables>).

## Installing a DIMM

### Procedure

1. **Power down the server.**
2. Remove all power:
  - a. Disconnect each power cord from the power source.
  - b. Disconnect each power cord from the server.
3. Disconnect all peripheral cables from the server.
4. Do one of the following:
  - **Extend the server from the rack.**
  - **Remove the server from the rack.**
5. **Remove the access panel.**
6. Install the DIMM:
  - a. Open the DIMM slot latches.
  - b. Align the notch on the bottom edge of the DIMM with the keyed surface of the DIMM slot, and then fully press the DIMM into the slot until the latches snap back into place.

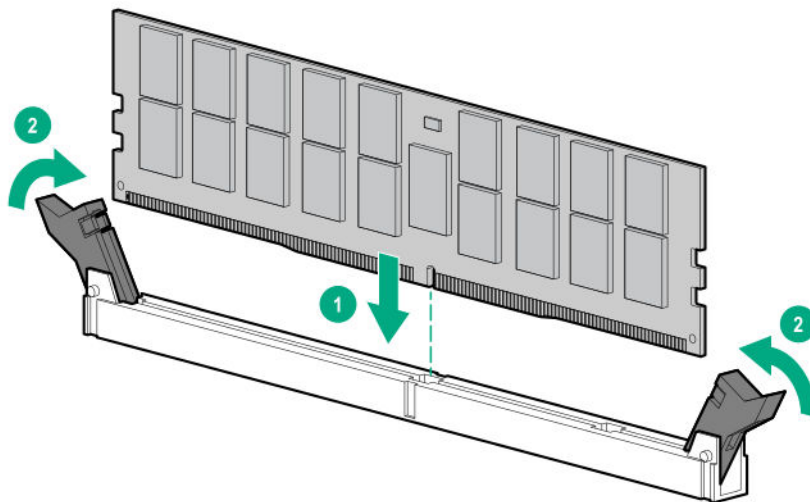

The DIMM slots are structured to ensure proper installation. If you try to insert a DIMM but it does not fit easily into the slot, you might have positioned it incorrectly. Reverse the orientation of the DIMM and insert it again.

7. **Install the access panel.**
8. **Install the server into the rack.**

9. Connect all peripheral cables to the server.
10. Connect each power cord to the server.
11. Connect each power cord to the power source.
12. **Power up the server.**

The installation is complete.

After installing the DIMMs, use the **System Utilities > System Configuration > BIOS/Platform Configuration (RBSU) > Memory Options** to configure the memory settings.

## Installing the FlexibleLOM adapter option

### Prerequisites

Before you perform this procedure, make sure that you have a T-15 Torx screwdriver available.

### Procedure

1. **Power down the server.**
2. Remove all power:
  - a. Disconnect each power cord from the power source.
  - b. Disconnect each power cord from the server.
3. Disconnect all peripheral cables from the server.
4. Do one of the following:
  - **Extend the server from the rack.**
  - **Remove the server from the rack.**
5. **Remove the access panel.**
6. If an expansion board is installed in the primary riser, do the following:
  - a. Disconnect the cables from the expansion board.
  - b. **Remove the primary riser cage.**
7. Remove the FlexibleLOM blank.

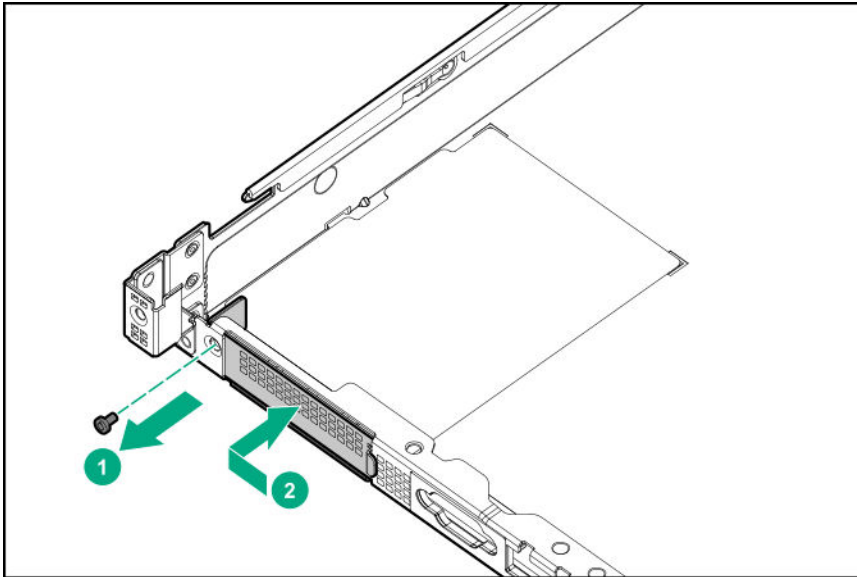

8. Install the FlexibleLOM adapter.

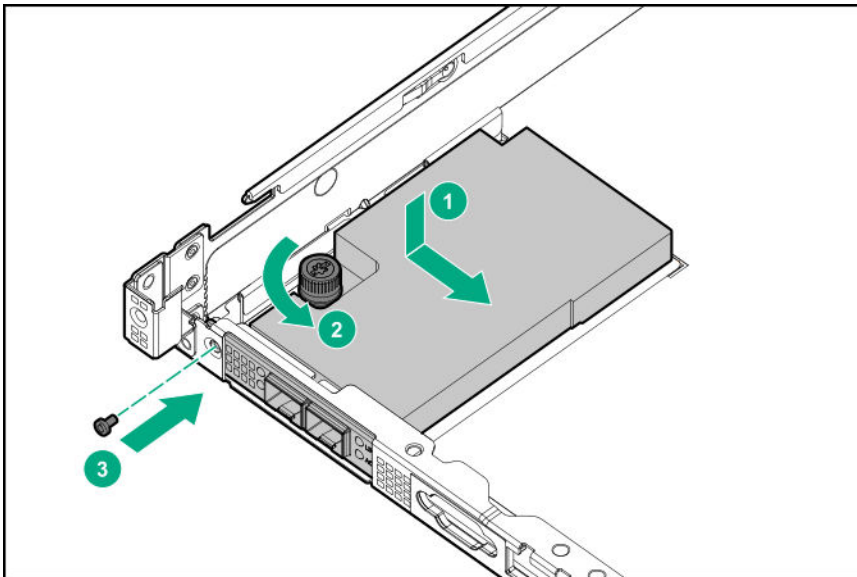

9. If removed, **install the primary riser cage.**
10. **Install the access panel.**
11. **Install the server into the rack.**
12. Connect all peripheral cables to the server.
13. Connect each power cord to the server.
14. Connect each power cord to the power source.
15. **Power up the server.**

The installation is complete.

# Installing the intrusion detection switch

## Procedure

1. **Power down the server.**
2. Remove all power:
  - a. Disconnect each power cord from the power source.
  - b. Disconnect each power cord from the server.
3. Disconnect all peripheral cables from the server.
4. Do one of the following:
  - **Extend the server from the rack.**
  - **Remove the server from the rack.**
5. **Remove the access panel.**
6. Install the intrusion detection switch.

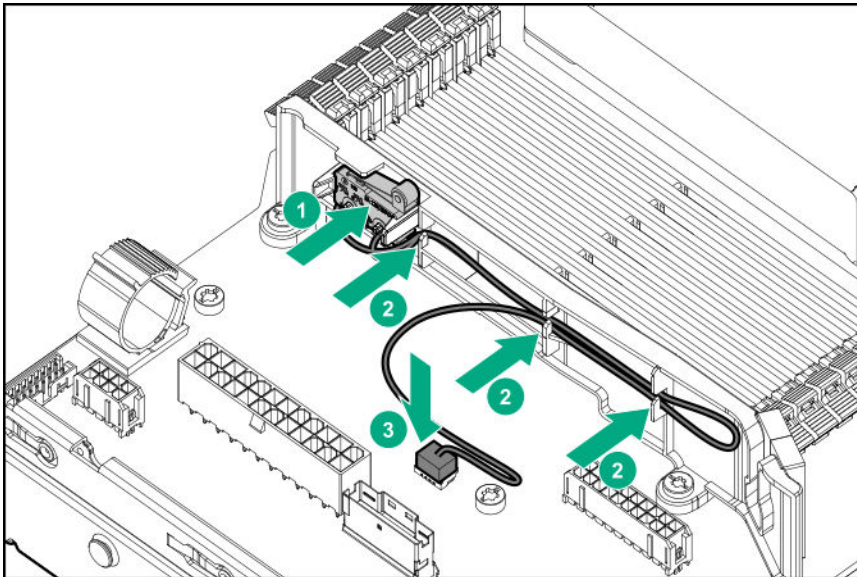

7. **Install the access panel.**
8. **Install the server into the rack.**
9. Connect all peripheral cables to the server.
10. Connect each power cord to the server.
11. Connect each power cord to the power source.
12. **Power up the server.**

The installation is complete.

# Installing the serial port

## Prerequisites

Before you perform this procedure, make sure that you have a nut driver.

## Procedure

1. **Power down the server.**
2. Remove all power:
  - a. Disconnect each power cord from the power source.
  - b. Disconnect each power cord from the server.
3. Disconnect all peripheral cables from the server.
4. Do one of the following:
  - **Extend the server from the rack.**
  - **Remove the server from the rack.**
5. **Remove the access panel.**
6. Do one of the following:
  - **Remove the secondary riser blank.**
  - If installed, remove the expansion board.

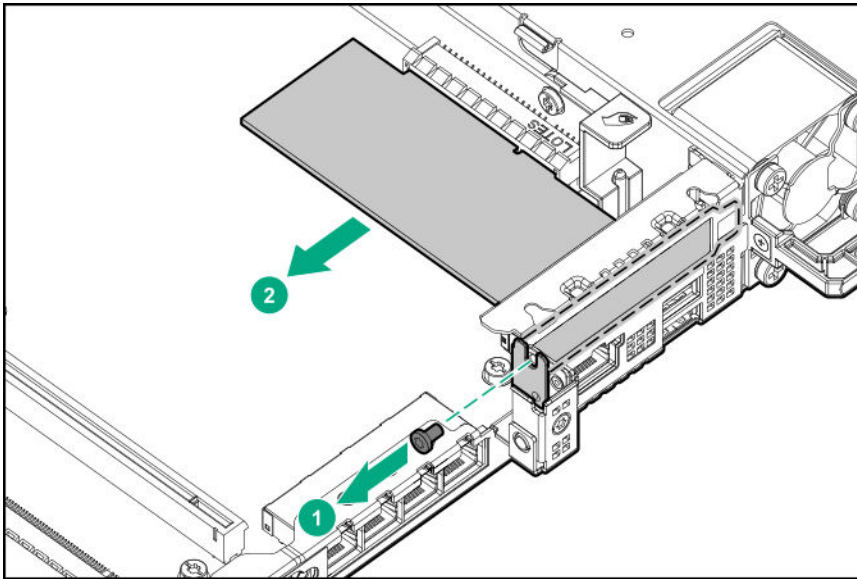

7. Install the serial port on the rear of the chassis.

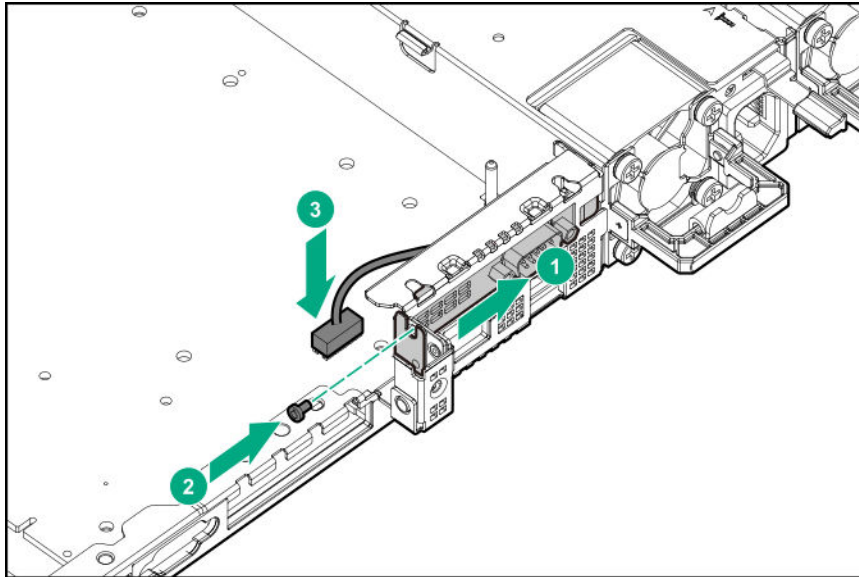

8. **Install the access panel.**
9. **Install the server into the rack.**
10. Connect all peripheral cables to the server.
11. Connect each power cord to the server.
12. Connect each power cord to the power source.
13. **Power up the server.**

The installation is complete.

## Redundant power supply (RPS) option

The redundant power supply (RPS) option consists of an RPS backplane assembly and two power supplies. With the RPS backplane and a single power supply installed in the server, you can install or remove a second power supply without powering down the server. Use the RPS option to improve power efficiency and enable power redundancy. To enable power redundancy, install two power supplies. Otherwise, the server will power down when a power supply is removed.

## Hot-plug power supply calculations

For hot-plug power supply specifications and calculators to determine electrical and heat loading for the server, see the Hewlett Packard Enterprise Power Advisor website (<http://www.hpe.com/info/poweradvisor/online>).

## Connecting a DC power cable to a DC power source



**WARNING:** To reduce the risk of electric shock or energy hazards:

- This equipment must be installed by trained service personnel, as defined by the NEC and IEC 60950-1, Second Edition, the standard for Safety of Information Technology Equipment.
- Connect the equipment to a reliably grounded Secondary circuit source. A Secondary circuit has no direct connection to a Primary circuit and derives its power from a transformer, converter, or equivalent isolation device.
- The branch circuit overcurrent protection must be rated 27 A.



---

**⚠ WARNING:** When installing a DC power supply, the ground wire must be connected before the positive or negative leads.

---

**⚠ WARNING:** Remove power from the power supply before performing any installation steps or maintenance on the power supply.

---

**⚠ CAUTION:** The server equipment connects the earthed conductor of the DC supply circuit to the earthing conductor at the equipment. For more information, see the documentation that ships with the power supply.

---

**⚠ CAUTION:** If the DC connection exists between the earthed conductor of the DC supply circuit and the earthing conductor at the server equipment, the following conditions must be met:

- This equipment must be connected directly to the DC supply system earthing electrode conductor or to a bonding jumper from an earthing terminal bar or bus to which the DC supply system earthing electrode conductor is connected.
  - This equipment should be located in the same immediate area (such as adjacent cabinets) as any other equipment that has a connection between the earthed conductor of the same DC supply circuit and the earthing conductor, and also the point of earthing of the DC system. The DC system should be earthed elsewhere.
  - The DC supply source is to be located within the same premises as the equipment.
  - Switching or disconnecting devices should not be in the earthed circuit conductor between the DC source and the point of connection of the earthing electrode conductor.
- 

To connect a DC power cable to a DC power source:

1. Cut the DC power cord ends no shorter than 150 cm (59.06 in).
2. If the power source requires ring tongues, use a crimping tool to install the ring tongues on the power cord wires.

**ⓘ IMPORTANT:** The ring terminals must be UL approved and accommodate 12 gauge wires.

---

**ⓘ IMPORTANT:** The minimum nominal thread diameter of a pillar or stud type terminal must be 3.5 mm (0.138 in); the diameter of a screw type terminal must be 4.0 mm (0.157 in).

---

3. Stack each same-colored pair of wires and then attach them to the same power source. The power cord consists of three wires (black, red, and green).

For more information, see the documentation that ships with the power supply.

## Installing the redundant power supply option

---

**⚠ CAUTION:** Avoid tight bend radii to prevent damaging the internal wires of a power cord or a server cable. Never bend power cords and server cables tight enough to cause a crease in the sheathing.

---

### Prerequisites

Before you perform this procedure, make sure that you have the following items available:

- T-10 Torx screwdriver
- T-15 Torx screwdriver

## Procedure

1. **Power down the server.**
2. **Access the product rear panel.**
3. Release the power cord from the strain relief clip.

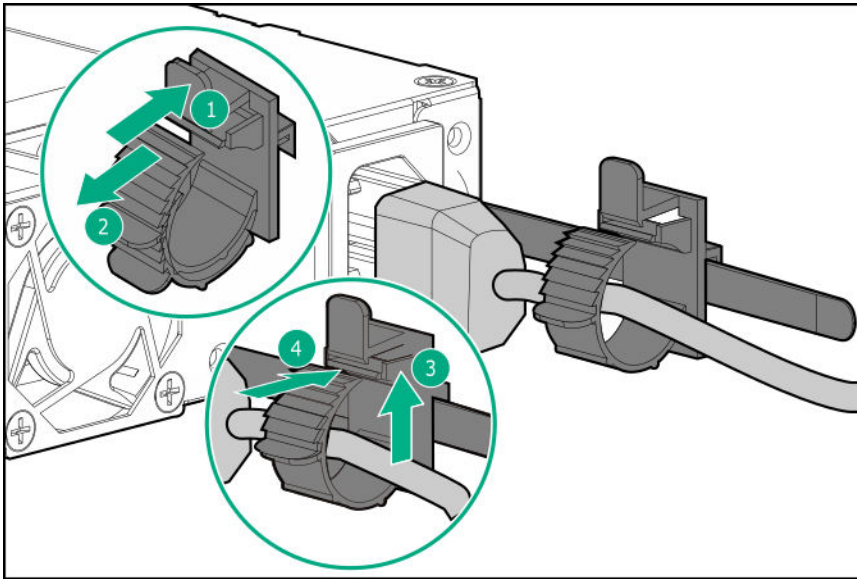

4. Remove all power:
  - a. Disconnect each power cord from the power source.
  - b. Disconnect each power cord from the server.
5. **Remove the server from the rack.**
6. Place the server on a sturdy, level surface.
7. **Remove the access panel.**
8. Remove the left rail.
  - a. Pull the latch on the inner rail.
  - b. Detach the inner rail from the server.

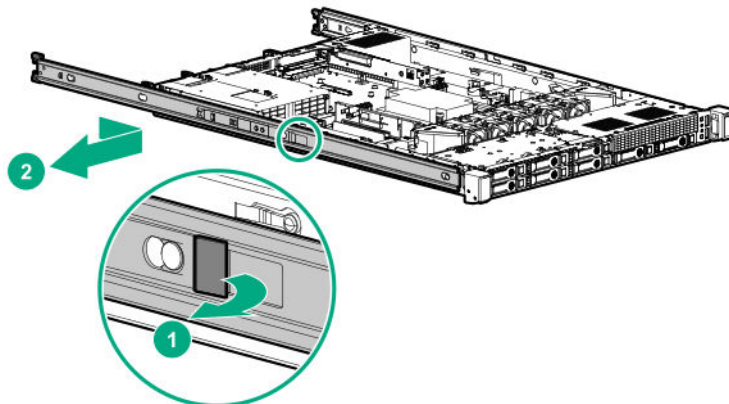

9. Remove the non-redundant power supply.

- a. Disconnect the power supply cable
- b. Remove four screws
- c. Remove the power supply

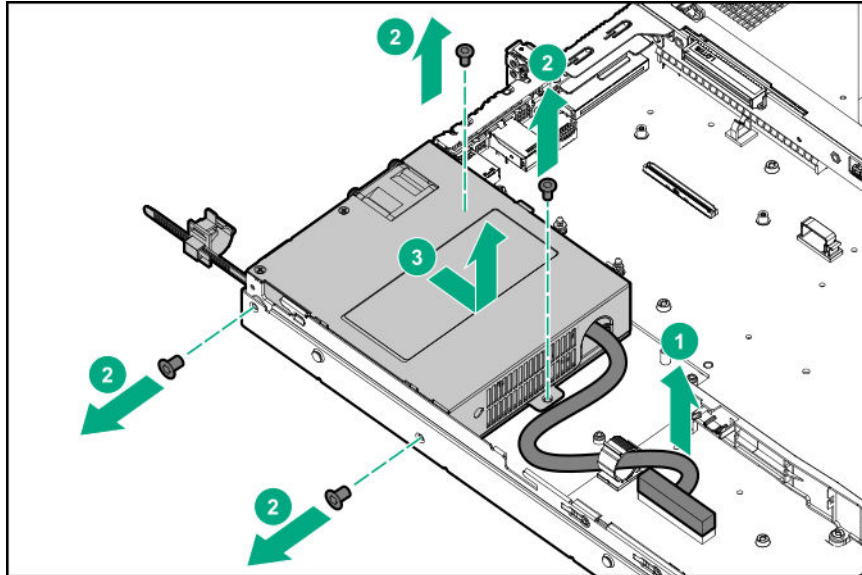

**10.** Install the RPS cage.

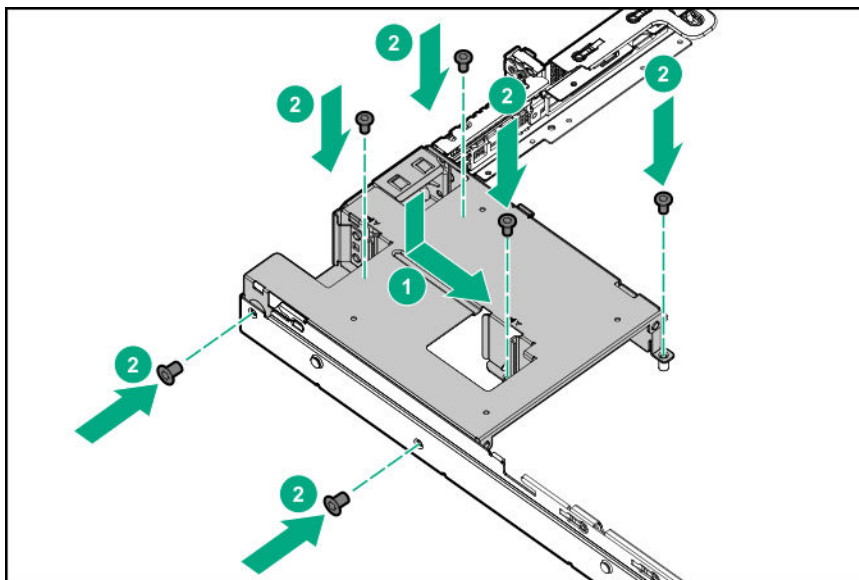

**11.** Install the power distribution board assembly.

- a. Install the power distribution board
- b. Install the power distribution board cover
- c. Secure the power distribution board assembly with three T-15 screws

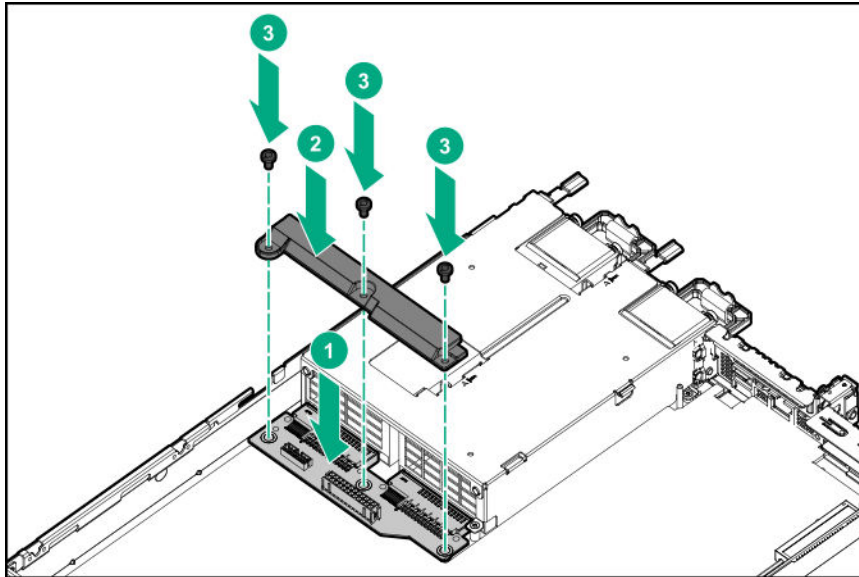

**12. Cable the RPS.**

- 13.** Install a hot-plug power supply in power supply bay 1.

For the power supply bay locations, see **Rear panel components**.

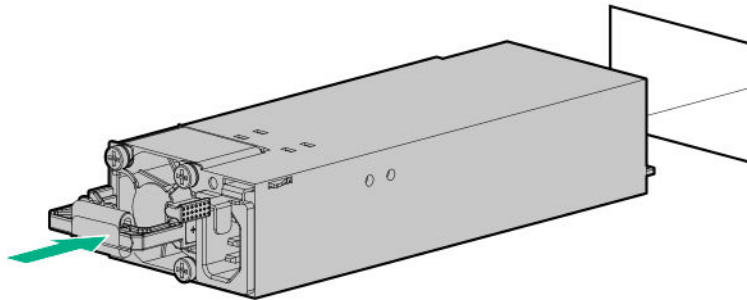

- 14.** To enable power redundancy in the server, install a second power supply in power supply bay 2:

- a.** Remove the power supply blank.

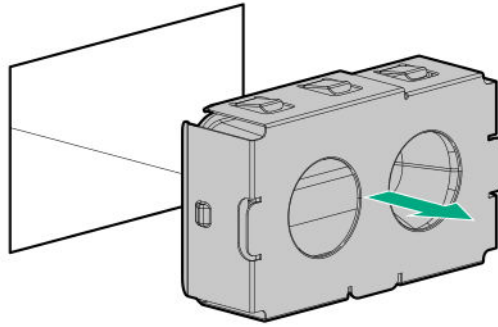

- b. Install a hot-plug power supply in power supply bay 2. Perform step 13.

**15. Install the access panel.**

- 16. Install the rail on chassis.

**17. Install the server into the rack.**

- 18. Connect the power cords to the power supplies.

- 19. To prevent accidentally disconnecting power cord when sliding the server into and from the rack, secure the power cord in the strain relief strap attached to the power supply handle:

- a. Unwrap the strain relief strap from the power supply handle.
- b. Bend the plug end of the power cord in the position shown in the following image.
- c. Secure the power cord with the strain relief strap.

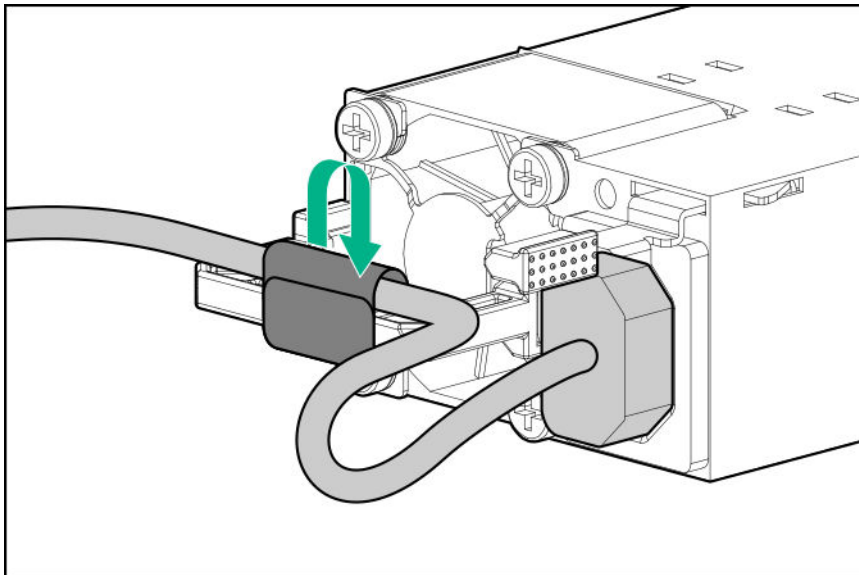

**20. Power up the server.**

The installation is complete.

## HPE Trusted Platform Module 2.0 Gen10 option

### Overview

Use these instructions to install and enable an HPE TPM 2.0 Gen10 Kit in a supported server. This option is not supported on Gen9 and earlier servers.

This procedure includes three sections:

1. Installing the Trusted Platform Module board.
2. Enabling the Trusted Platform Module.
3. Retaining the recovery key/password.

HPE TPM 2.0 installation is supported with specific operating system support such as Microsoft® Windows Server® 2012 R2 and later. For more information about operating system support, see the product QuickSpecs on the Hewlett Packard Enterprise website (<http://www.hpe.com/info/qs>). For more information about Microsoft® Windows® BitLocker Drive Encryption feature, see the Microsoft website (<http://www.microsoft.com>).

---

**⚠ CAUTION:** If the TPM is removed from the original server and powered up on a different server, data stored in the TPM including keys will be erased.

---

**❗ IMPORTANT:** In UEFI Boot Mode, the HPE TPM 2.0 Gen10 Kit can be configured to operate as TPM 2.0 (default) or TPM 1.2 on a supported server. In Legacy Boot Mode, the configuration can be changed between TPM 1.2 and TPM 2.0, but only TPM 1.2 operation is supported.

---

### HPE Trusted Platform Module 2.0 Guidelines

---

**⚠ CAUTION:** Always observe the guidelines in this document. Failure to follow these guidelines can cause hardware damage or halt data access.

---

**Hewlett Packard Enterprise SPECIAL REMINDER:** Before enabling TPM functionality on this system, you must ensure that your intended use of TPM complies with relevant local laws, regulations and policies, and approvals or licenses must be obtained if applicable.

For any compliance issues arising from your operation/usage of TPM which violates the above mentioned requirement, you shall bear all the liabilities wholly and solely. Hewlett Packard Enterprise will not be responsible for any related liabilities.

慧与特别提醒：在您启用系统中的TPM功能前，请务必确认您对TPM的使用遵守当地相关法律、法规及政策，并已事先获得所需的一切批准及许可（如适用），因您未获得相应的操作/使用许可而导致的违规问题，皆由您自行承担全部责任，与慧与无涉。

When installing or replacing a TPM, observe the following guidelines:

- Do not remove an installed TPM. Once installed, the TPM becomes a permanent part of the system board.
- When installing or replacing hardware, Hewlett Packard Enterprise service providers cannot enable the TPM or the encryption technology. For security reasons, only the customer can enable these features.
- When returning a system board for service replacement, do not remove the TPM from the system board. When requested, Hewlett Packard Enterprise Service provides a TPM with the spare system board.

- Any attempt to remove the cover of an installed TPM from the system board can damage the TPM cover, the TPM, and the system board.
- If the TPM is removed from the original server and powered up on a different server, data stored in the TPM including keys will be erased.
- When using BitLocker, always retain the recovery key/password. The recovery key/password is required to complete Recovery Mode after BitLocker detects a possible compromise of system integrity.
- Hewlett Packard Enterprise is not liable for blocked data access caused by improper TPM use. For operating instructions, see the TPM documentation or the encryption technology feature documentation provided by the operating system.

## Installing and enabling the HPE TPM 2.0 Gen10 Kit

### Installing the Trusted Platform Module board

#### Preparing the server for installation

##### Procedure

1. Observe the following warnings:



**WARNING:** The front panel Power On/Standby button does not shut off system power. Portions of the power supply and some internal circuitry remain active until AC power is removed.

To reduce the risk of personal injury, electric shock, or damage to the equipment, remove power from the server:

For rack and tower servers, remove the power cord.

For server blades and compute modules, remove the server blade or compute module from the enclosure.

---

---



**WARNING:** To reduce the risk of personal injury from hot surfaces, allow the drives and the internal system components to cool before touching them.

---

2. Update the system ROM.

Locate and download the latest ROM version from the [Hewlett Packard Enterprise Support Center website](#). Follow the instructions on the website to update the system ROM.

3. **Power down the server.**

4. Do one of the following:

- **Extend the server from the rack.**
- **Remove the server from the rack.**

5. Place the server on a flat, level work surface.

6. **Remove the access panel.**

7. Remove any components or cables that may prevent access to the TPM connector.

8. **Installing the TPM board and cover** on page 96.

## Installing the TPM board and cover

### Procedure

1. Observe the following alerts:

---

**⚠ CAUTION:** If the TPM is removed from the original server and powered up on a different server, data stored in the TPM including keys will be erased.

---

**⚠ CAUTION:** The TPM is keyed to install only in the orientation shown. Any attempt to install the TPM in a different orientation might result in damage to the TPM or system board.

---

2. Align the TPM board with the key on the connector, and then install the TPM board. To seat the board, press the TPM board firmly into the connector. To locate the TPM connector on the system board, see the server label on the access panel.

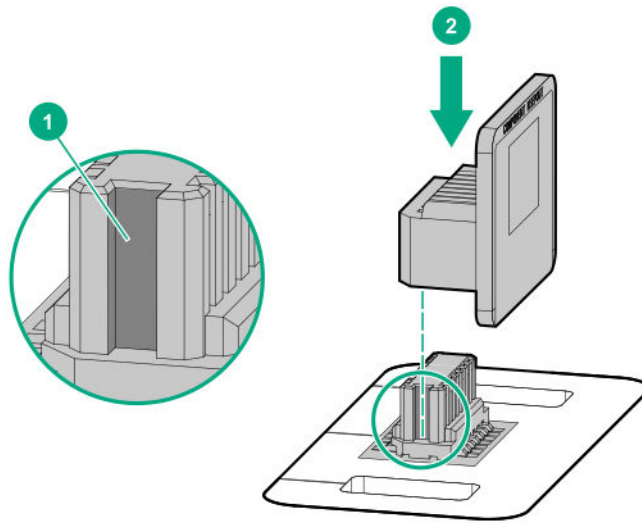

3. Install the TPM cover:

- a. Line up the tabs on the cover with the openings on either side of the TPM connector.
- b. To snap the cover into place, firmly press straight down on the middle of the cover.



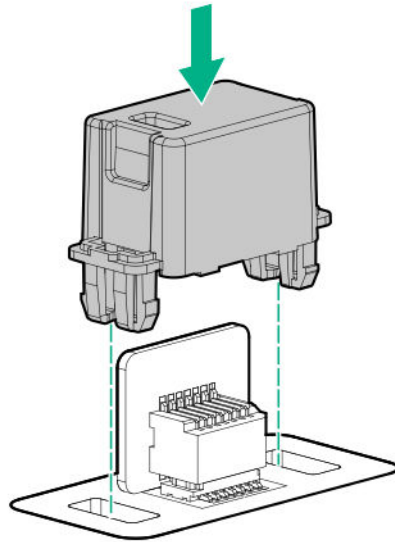

4. Proceed to **Preparing the server for operation** on page 97.

## Preparing the server for operation

### Procedure

1. Install any options or cables previously removed to access the TPM connector.
2. **Install the access panel.**
3. **Install the server into the rack.**
4. Connect the power cords to the server.
5. **Power up the server.**

## Enabling the Trusted Platform Module

When enabling the Trusted Platform module, observe the following guidelines:

- By default, the Trusted Platform Module is enabled as TPM 2.0 when the server is powered on after installing it.
- In UEFI Boot Mode, the Trusted Platform Module can be configured to operate as TPM 2.0 or TPM 1.2.
- In Legacy Boot Mode, the Trusted Platform Module configuration can be changed between TPM 1.2 and TPM 2.0, but only TPM 1.2 operation is supported.

## Enabling the Trusted Platform Module as TPM 2.0

### Procedure

1. During the server startup sequence, press the **F9** key to access **System Utilities**.
2. From the System Utilities screen, select **System Configuration > BIOS/Platform Configuration (RBSU) > Server Security > Trusted Platform Module options**.
3. Verify the following:

- "Current TPM Type" is set to **TPM 2.0**.
  - "Current TPM State" is set to **Present and Enabled**.
  - "TPM Visibility" is set to **Visible**.
4. If changes were made in the previous step, press the **F10** key to save your selection.
  5. If F10 was pressed in the previous step, do one of the following:
    - If in graphical mode, click **Yes**.
    - If in text mode, press the **Y** key.
  6. Press the **ESC** key to exit System Utilities.
  7. If changes were made and saved, the server prompts for reboot request. Press the **Enter** key to confirm reboot.
 

If the following actions were performed, the server reboots a second time without user input. During this reboot, the TPM setting becomes effective.

    - Changing from TPM 1.2 and TPM 2.0
    - Changing TPM bus from FIFO to CRB
    - Enabling or disabling TPM
    - Clearing the TPM
  8. Enable TPM functionality in the OS, such as Microsoft Windows BitLocker or measured boot.
 

For more information, see the [Microsoft website](#).

## Enabling the Trusted Platform Module as TPM 1.2

### Procedure

1. During the server startup sequence, press the **F9** key to access **System Utilities**.
2. From the System Utilities screen select **System Configuration > BIOS/Platform Configuration (RBSU) > Server Security > Trusted Platform Module options**.
3. Change the "TPM Mode Switch Operation" to **TPM 1.2**.
4. Verify "TPM Visibility" is **Visible**.
5. Press the **F10** key to save your selection.
6. When prompted to save the change in System Utilities, do one of the following:
  - If in graphical mode, click **Yes**.
  - If in text mode, press the **Y** key.
7. Press the **ESC** key to exit System Utilities.
 

The server reboots a second time without user input. During this reboot, the TPM setting becomes effective.
8. Enable TPM functionality in the OS, such as Microsoft Windows BitLocker or measured boot.

For more information, see the [Microsoft website](#).

## **Retaining the recovery key/password**

The recovery key/password is generated during BitLocker setup, and can be saved and printed after BitLocker is enabled. When using BitLocker, always retain the recovery key/password. The recovery key/password is required to enter Recovery Mode after BitLocker detects a possible compromise of system integrity.

To help ensure maximum security, observe the following guidelines when retaining the recovery key/password:

- Always store the recovery key/password in multiple locations.
- Always store copies of the recovery key/password away from the server.
- Do not save the recovery key/password on the encrypted hard drive.

# Cabling

## Cabling guidelines

The cable colors in the cabling diagrams used in this chapter are for illustration purposes only. Most of the server cables are black.

Observe the following guidelines when working with server cables.

### Before connecting cables

- Note the port labels on the PCA components. Not all of these components are used by all servers:
  - System board ports
  - Drive and power supply backplane ports
  - Expansion board ports (controllers, adapters, expanders, risers, and similar boards)
- Note the label near each cable connector. This label indicates the destination port for the cable connector.
- Some data cables are pre-bent. Do not unbend or manipulate the cables.
- To prevent mechanical damage or depositing oil that is present on your hands, and other contamination, do not touch the ends of the connectors.

### When connecting cables

- Before connecting a cable to a port, lay the cable in place to verify the length of the cable.
- Use the internal cable management features to properly route and secure the cables.
- When routing cables, be sure that the cables are not in a position where they can be pinched or crimped.
- Avoid tight bend radii to prevent damaging the internal wires of a power cord or a server cable. Never bend power cords and server cables tight enough to cause a crease in the sheathing.
- Make sure that the excess length of cables are properly secured to avoid excess bends, interference issues, and airflow restriction.
- To prevent component damage and potential signal interference, make sure that all cables are in their appropriate routing position before installing a new component and before closing up the server after hardware installation/maintenance.

### When disconnecting cables

- Grip the body of the cable connector. Do not pull on the cable itself because this action can damage the internal wires of the cable or the pins on the port.
- If a cable does not disconnect easily, check for any release latch that must be pressed to disconnect the cable.

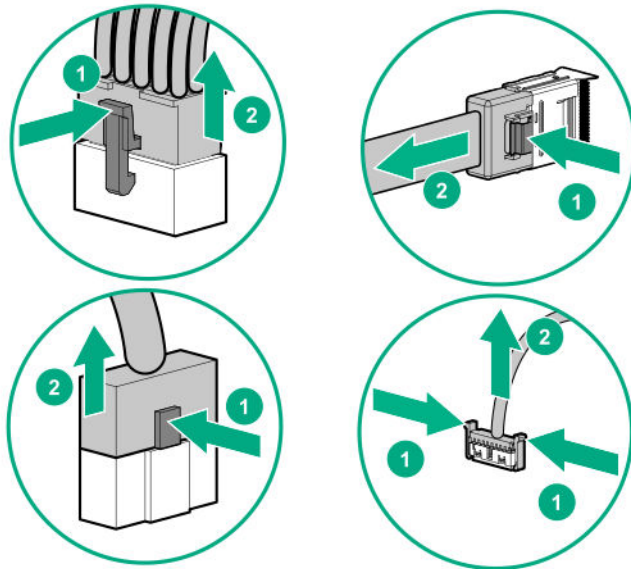

- Remove cables that are no longer being used. Retaining them inside the server can restrict airflow. If you intend to use the removed cables later, label and store them for future use.

## Cable routing: 4LFF drive model

- 4LFF drive connected to system board

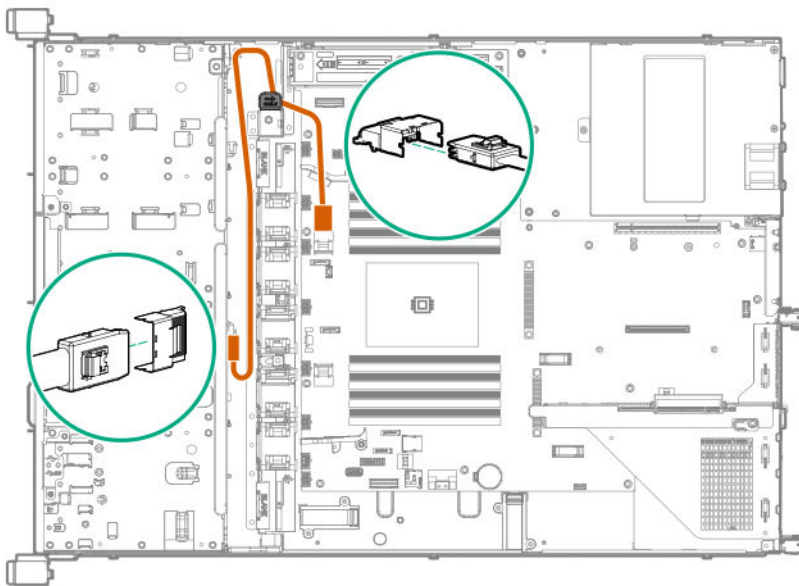

- 4LFF drive connected to Embedded HPE Smart Array S100i SR Gen10 Controller

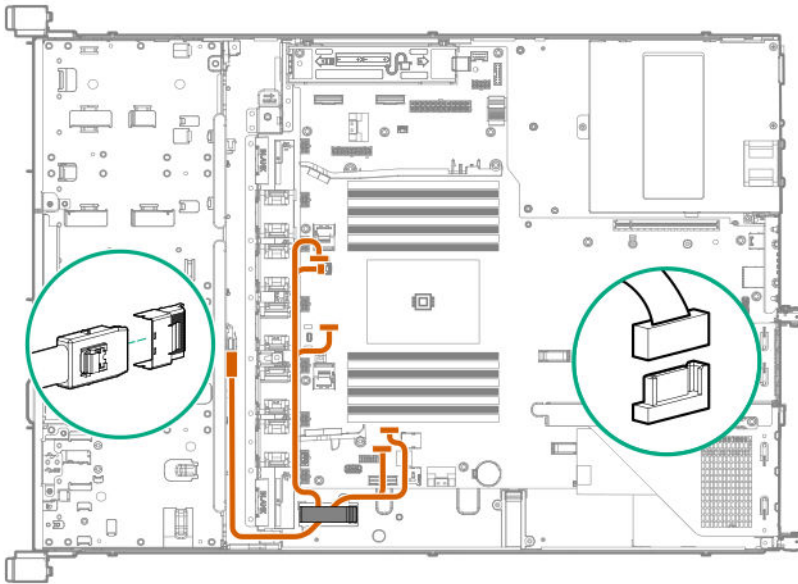

- 4LFF drive connected to type-a controller

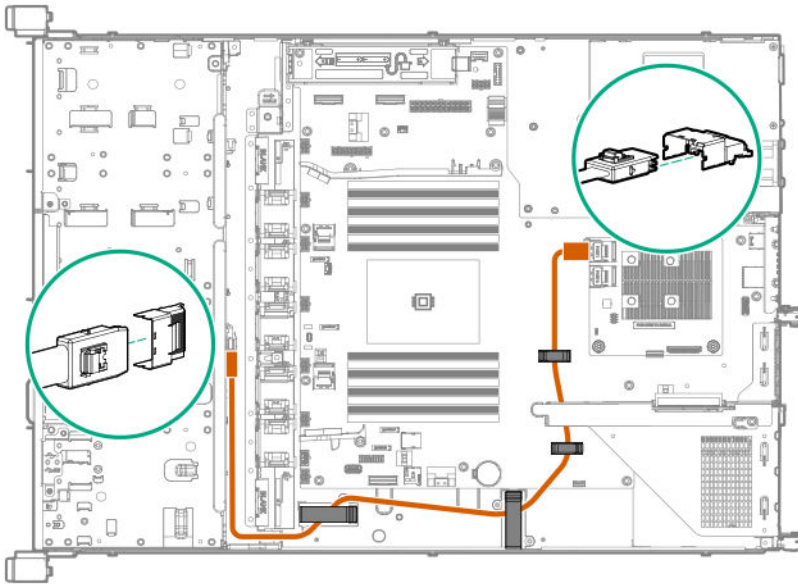

- 4LFF drive connected to type-p controller
  - Slot 1

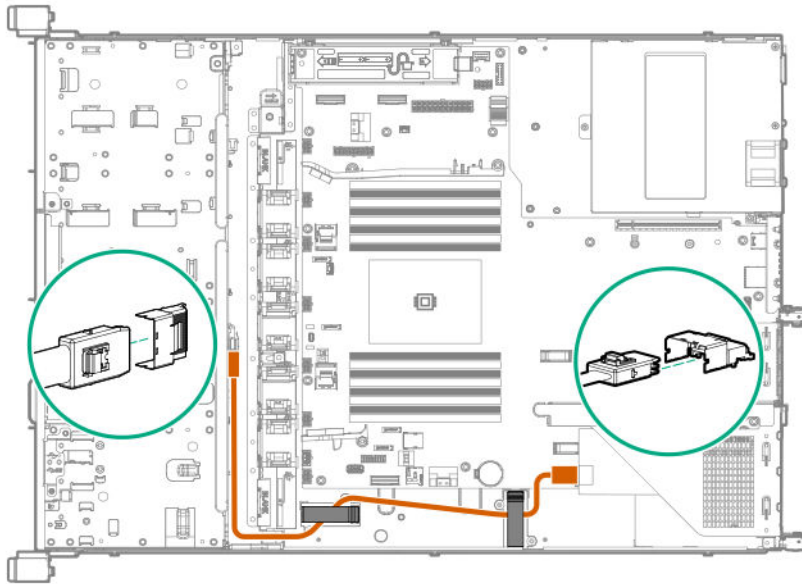

- Slot 2

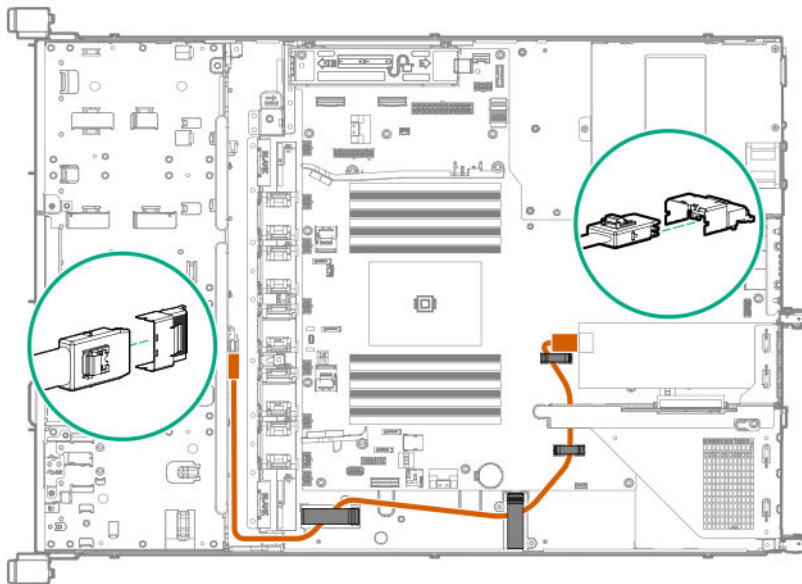

- Slot 3

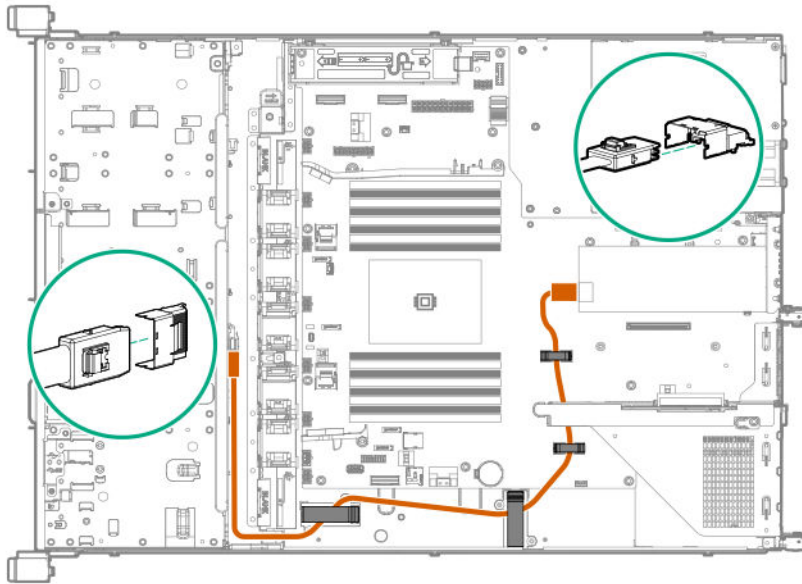

- 4LF drive power cable

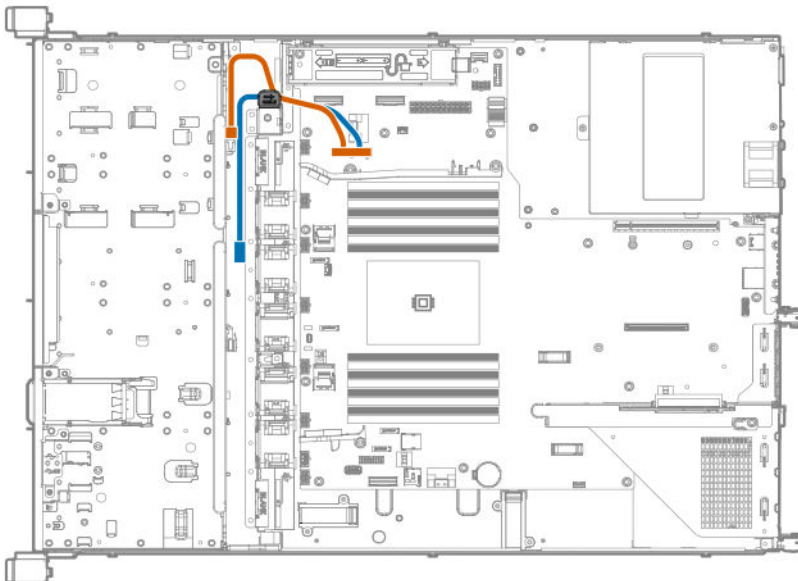

Cable color	Description
Orange	Power cable from system board to drive backplane
Blue	Power cable from system board to ODD (reserved)

## Cable routing: 8SFF SAS/SATA drive model

- 8SFF drive connected to system board



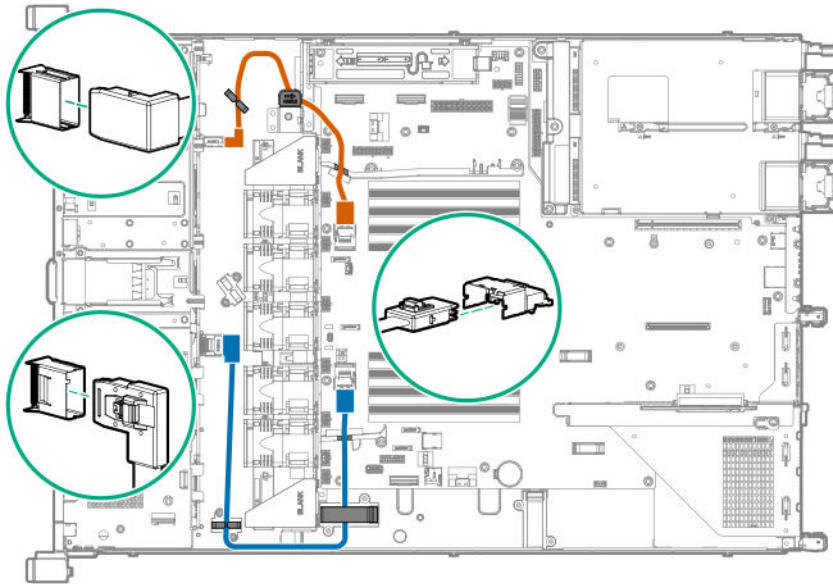

Cable color	Description
Orange	SATA cable from port 1 backplane to port 1 system board
Blue	SATA cable from port 2 backplane to port 2 system board

- 8SFF drive connected to type-a controller

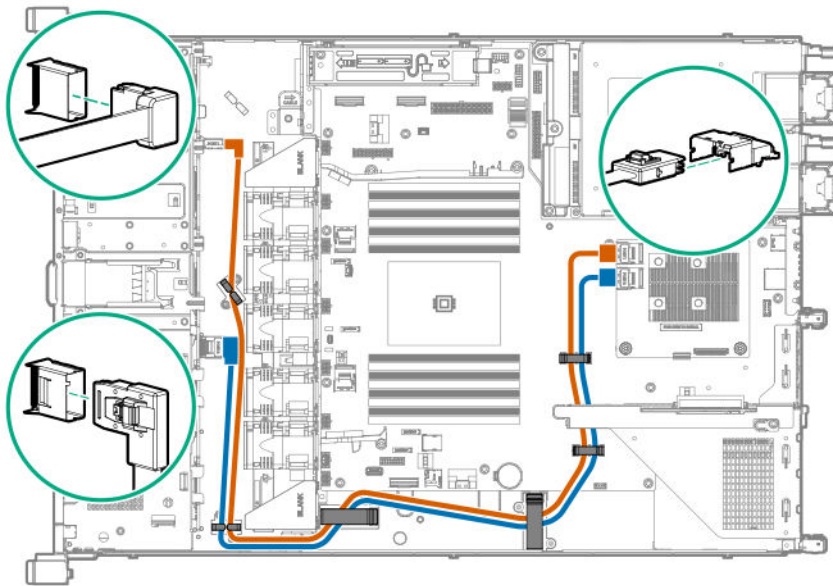

Cable color	Description
Orange	Mini-SAS cable from port 1 backplane to port 1 type-a controller
Blue	Mini-SAS cable from port 2 backplane to port 2 type-a controller

- 8SFF drive connected to type-p controller
  - Slot 1

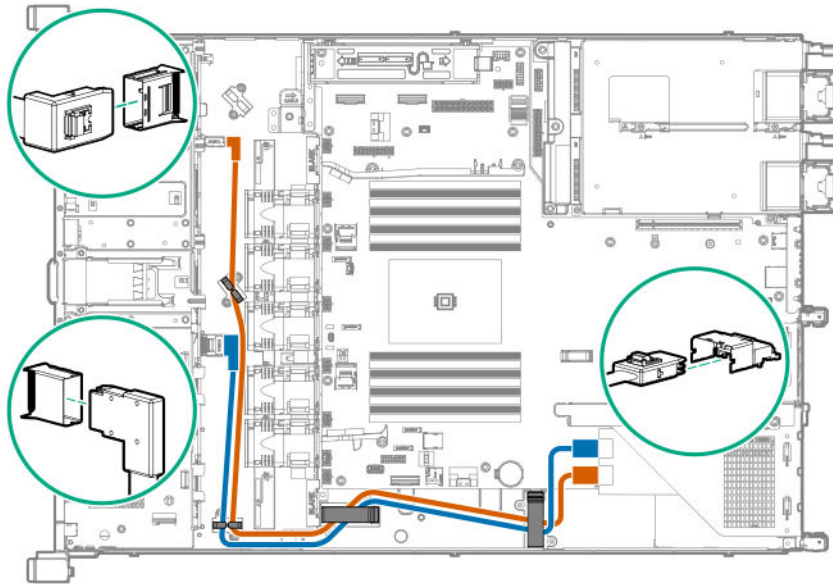

- Slot 2

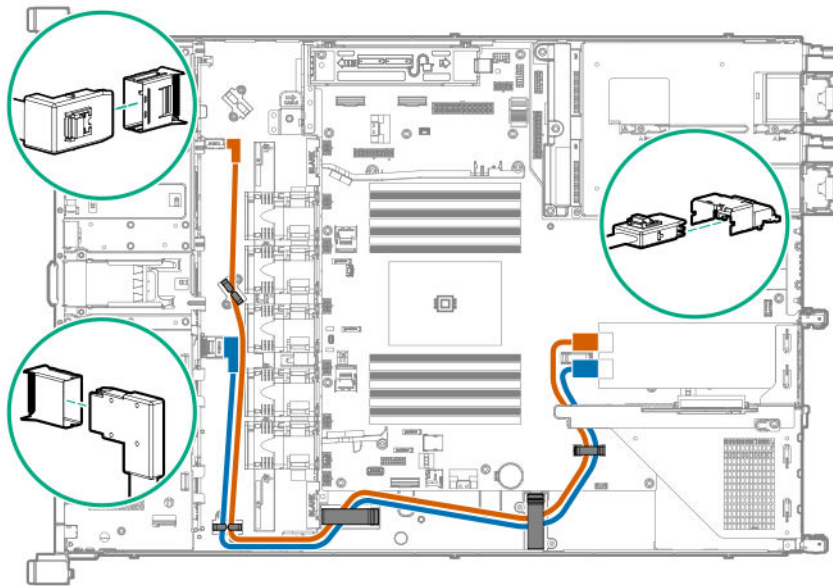

- Slot 3

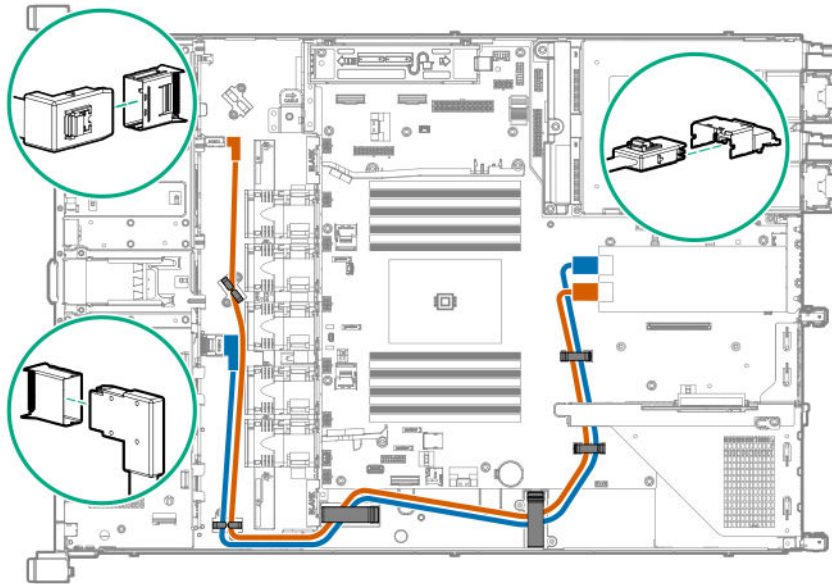

Cable color	Description
Orange	Mini-SAS cable from port 1 backplane to port 1 type-p controller
Blue	Mini-SAS cable from port 2 backplane to port 2 type-p controller

- 8SFF SAS/SATA drive power cable

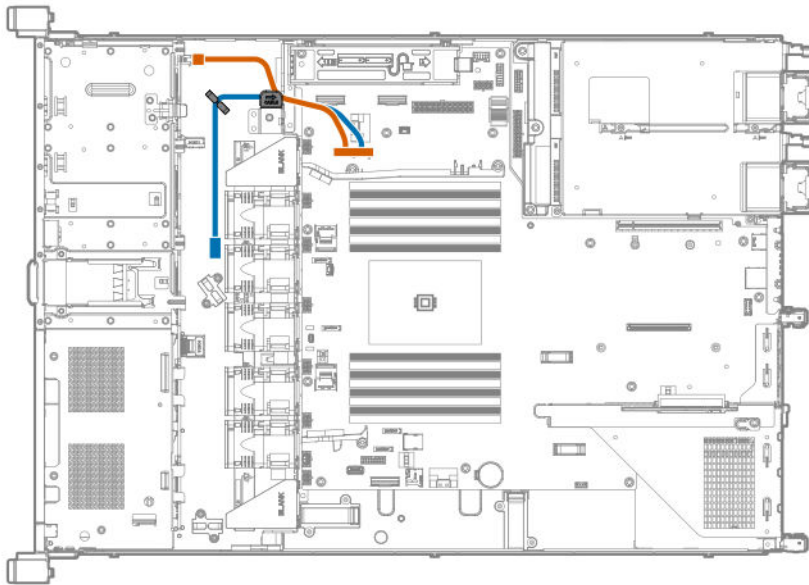

Cable color	Description
Orange	Power cable from system board to drive backplane
Blue	Power cable from system board to ODD (reserved)

## Cable routing: 8SFF NVMe drive model

- 8NVMe drive connected to system board

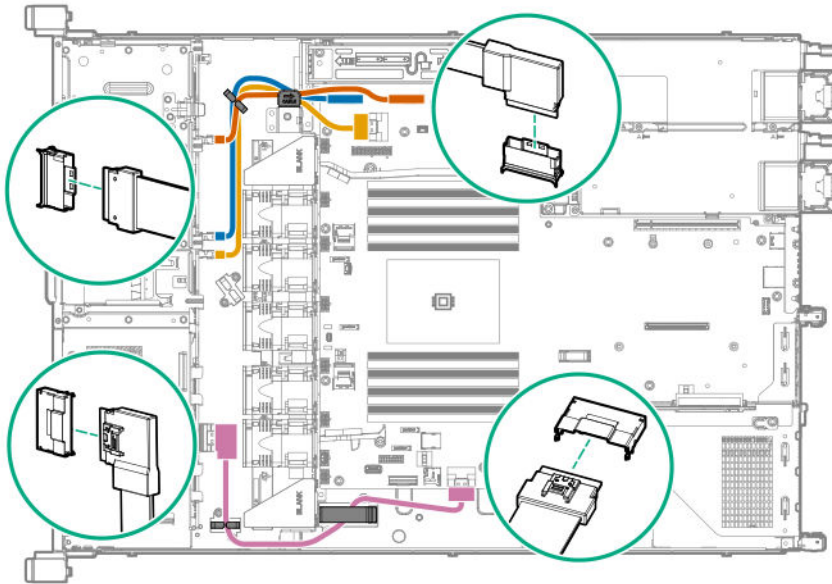

Item	Description
Orange	Slimline cable to NVMe port 1A on system board
Blue	Slimline cable to NVMe port 2A on system board
Gold	Slimline cable to NVMe port 3A on system board
Pink	Slimline cable to NVMe port 4A on system board

- **8NVMe drive power cable**

## Cable routing: 2SFF SAS/SATA drive cage

- SATA cable to system board

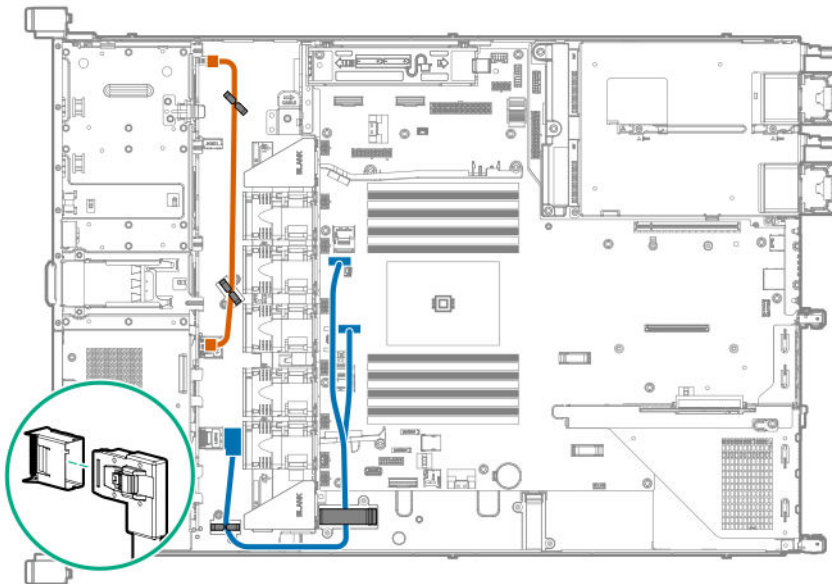

Item	Description
Orange	Power cable from 8SFF drive backplane to 2SFF drive backplane
Blue	SATA cable to SATA ports 1 & 2 on system board

- Mini-SAS cable to type-a controller

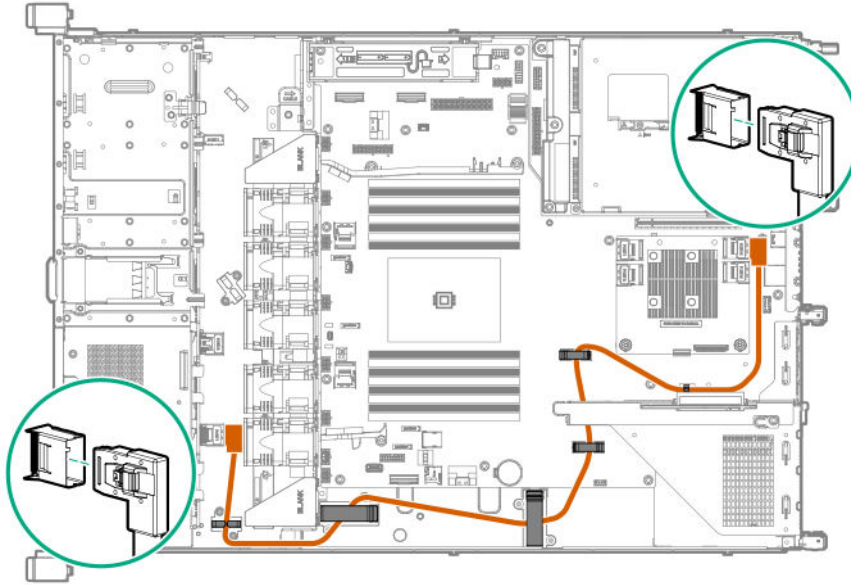

## Cable routing: 2SFF NVMe drive cage

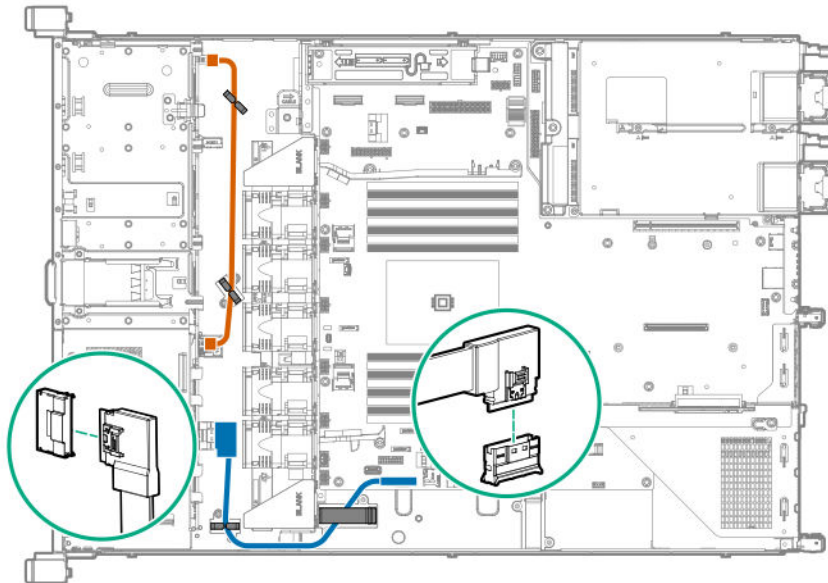

Item	Description
Orange	Power cable from 8SFF drive backplane to 2SFF drive backplane
Blue	Slimline cable to NVMe port 5A on system board

## Cable routing: Optical Drive

- LFF

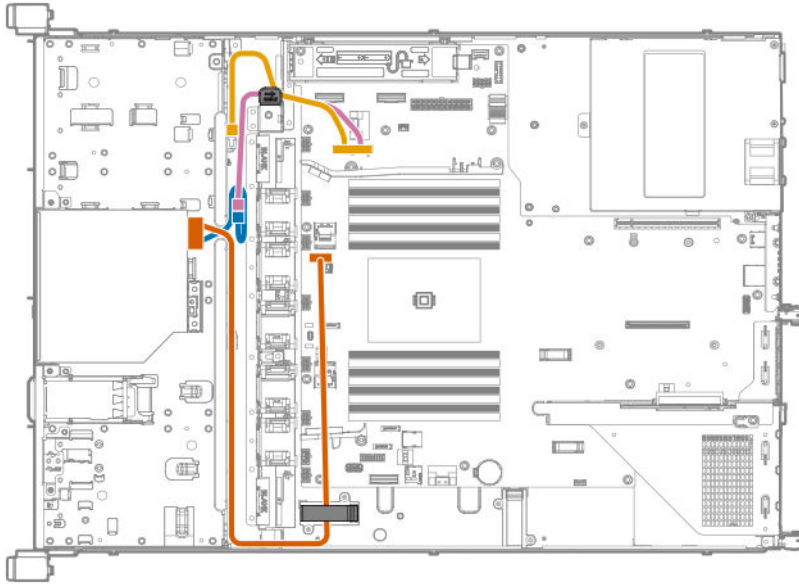

Item	Description
Orange	ODD SATA cable
Blue	ODD power cable
Pink	Power cable from system board to ODD
Gold	Power cable from system board to drive backplane

- SFF

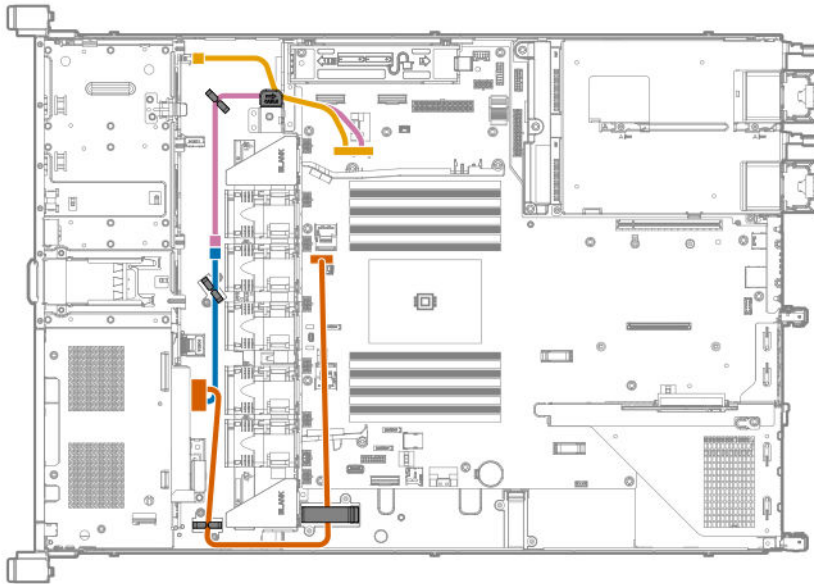

Item	Description
Orange	ODD SATA cable
Blue	ODD power cable
Pink	Power cable from system board to ODD
Gold	Power cable from system board to drive backplane

## Cable routing: iLO service port

- LFF

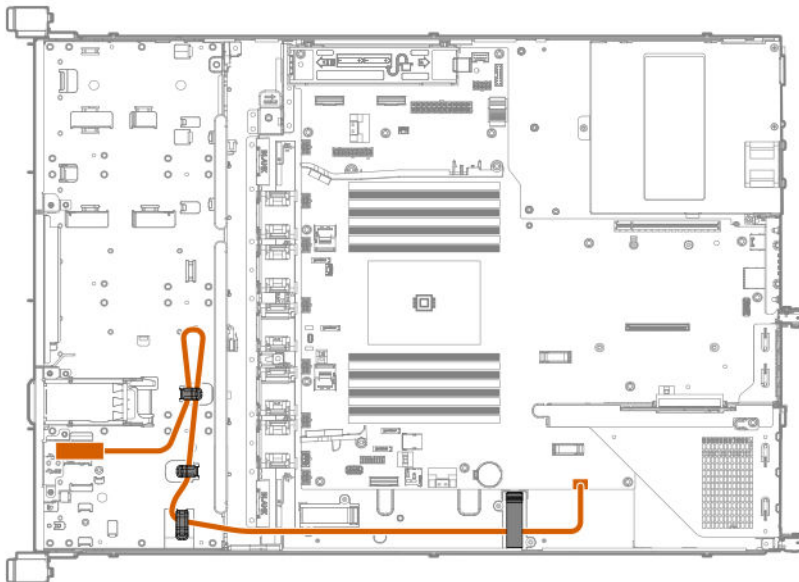

- SFF

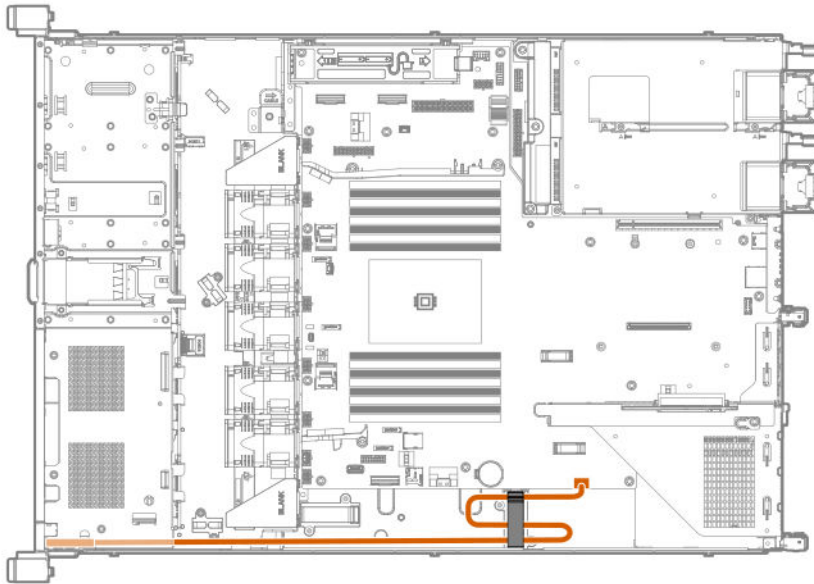

## Cable routing: Power supply

- Non-hot-plug power supply

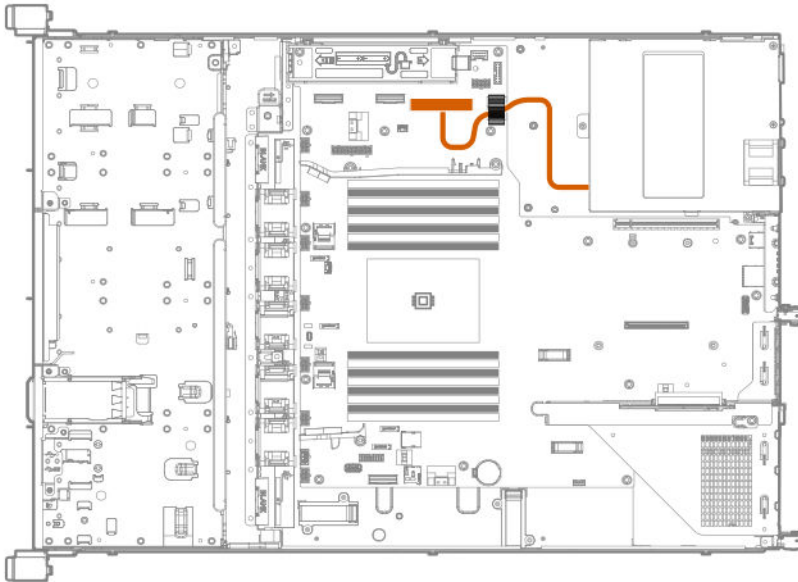

- Power distribution board (PDB) to system board



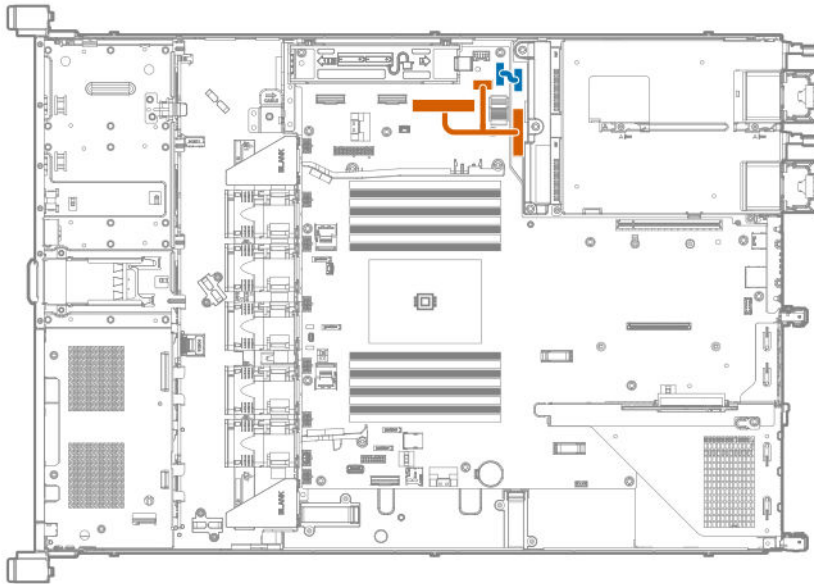

Item	Description
Orange	Power cable
Blue	Sideband signal cable

## Cable routing: GPU

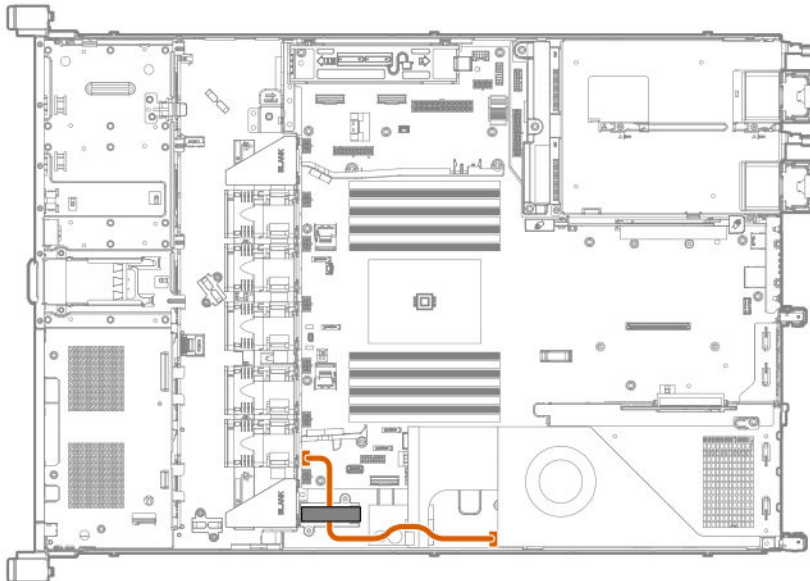

## Cable routing: Front I/O

- LFF

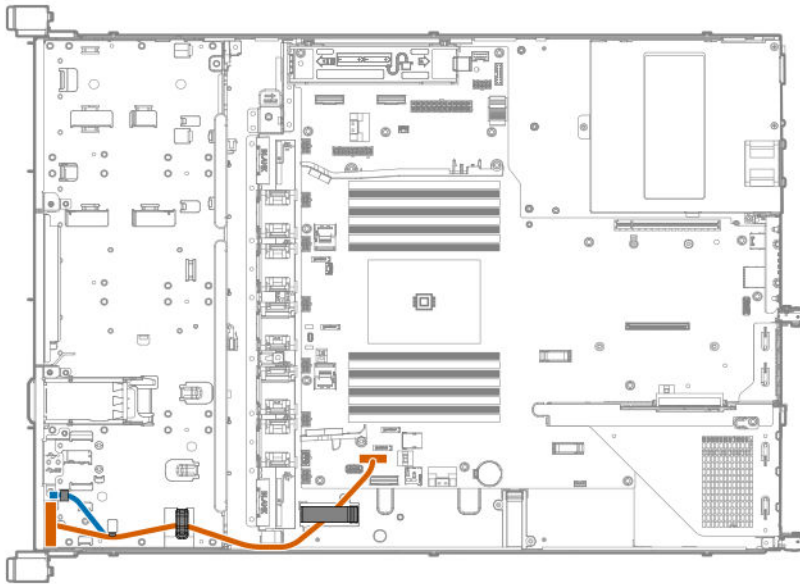

Item	Description
Orange	Front I/O cable
Blue	Ambient temperature sensor cable

- SFF

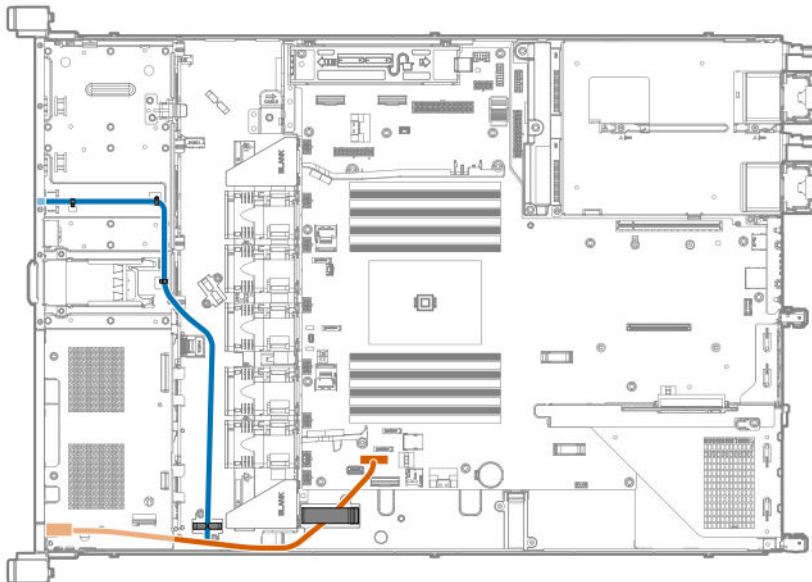

Item	Description
Orange	Front I/O cable
Blue	Ambient temperature sensor cable

## Cable routing: USB 3.0

- LFF

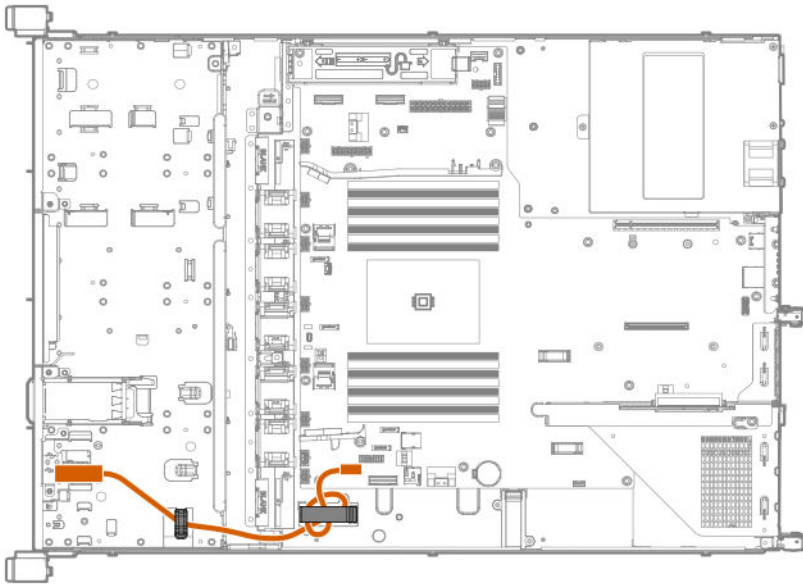

- SFF

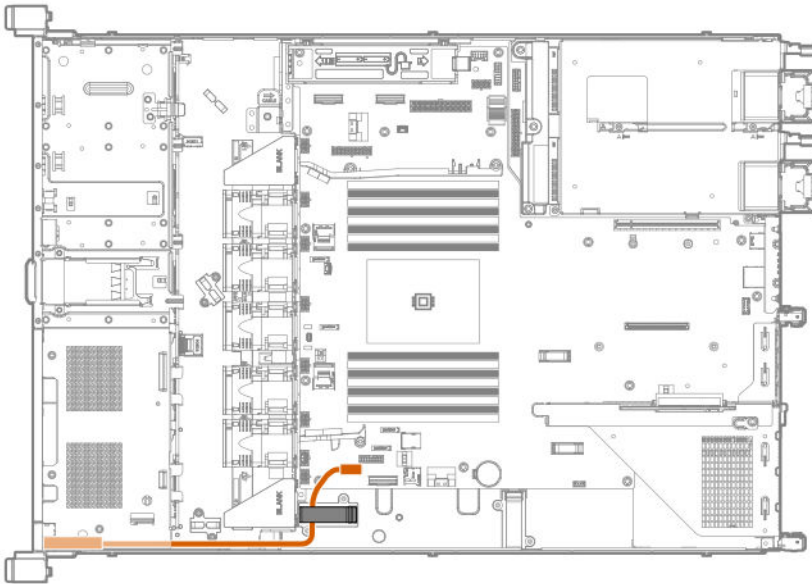

### Cable routing: Serial port

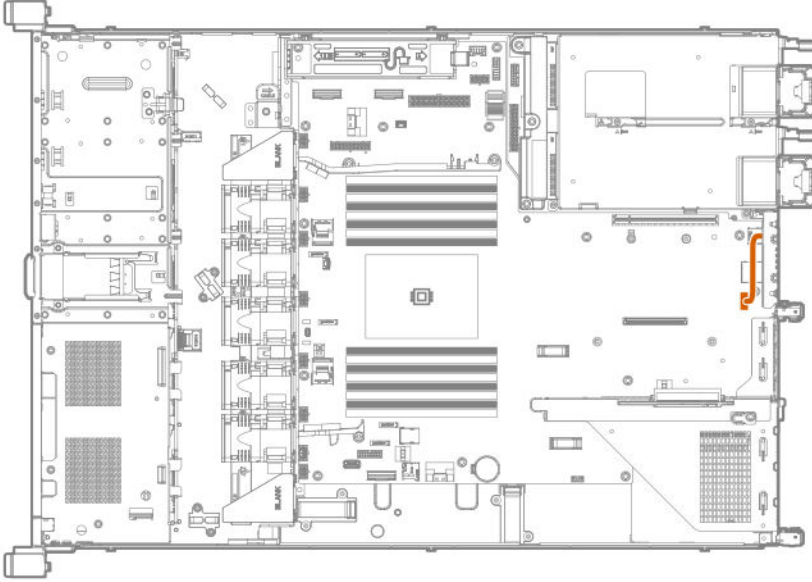

### Cable routing: Chassis Intrusion Detection switch

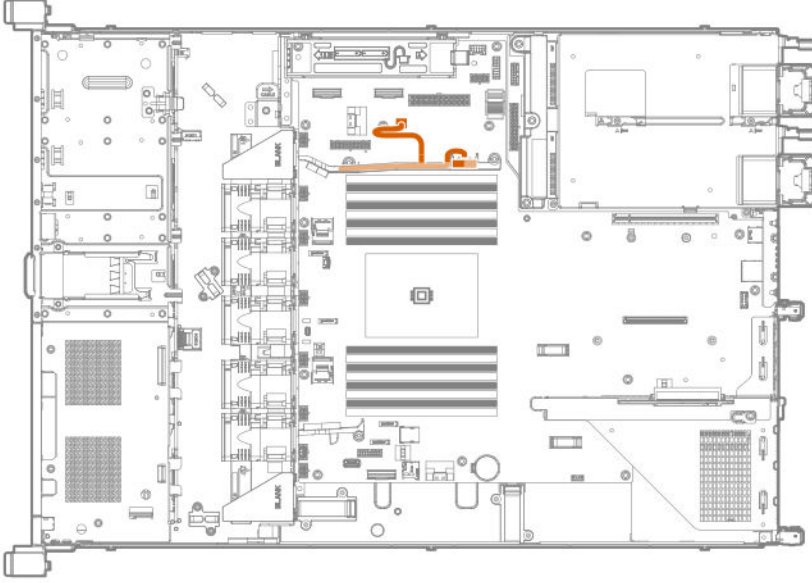

### Cable routing: M.2 SSD

- Slot 1

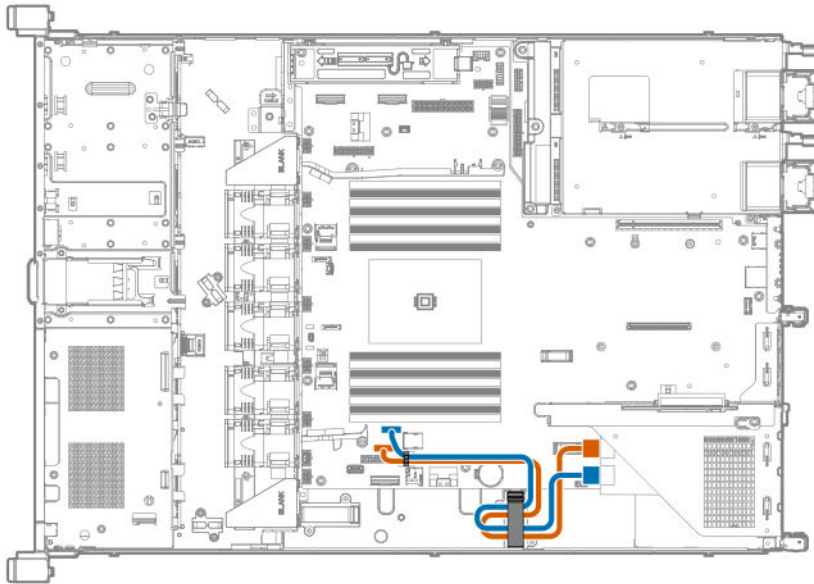

- Slot 2

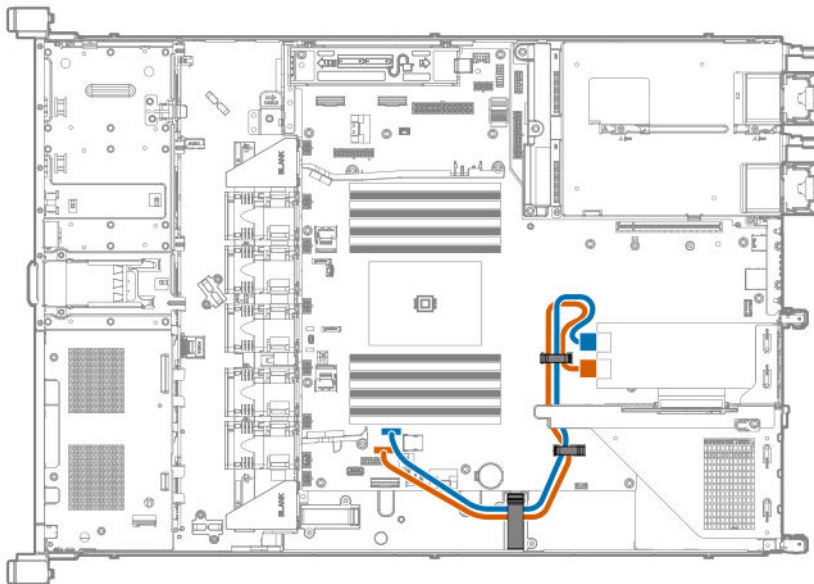

- Slot 3

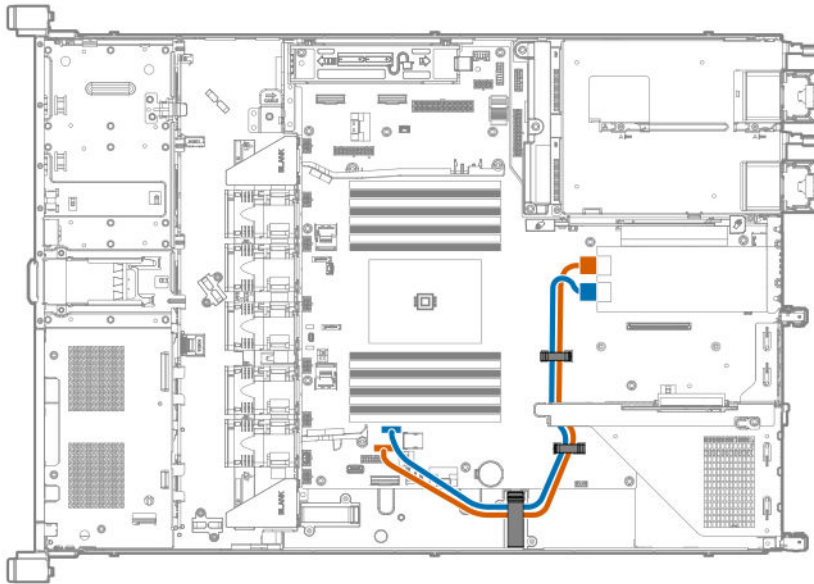

Item	Description
Blue	SATA cable from M.2 enablement board port 1 to x1 SATA port 3 on system board
Orange	SATA cable from M.2 enablement board port 2 to x1 SATA port 4 on system board

## Cable routing: Controller backup power cable

Depending on the controller option installed, the actual storage controller connectors might look different from what is shown in this section.

- Slot 1

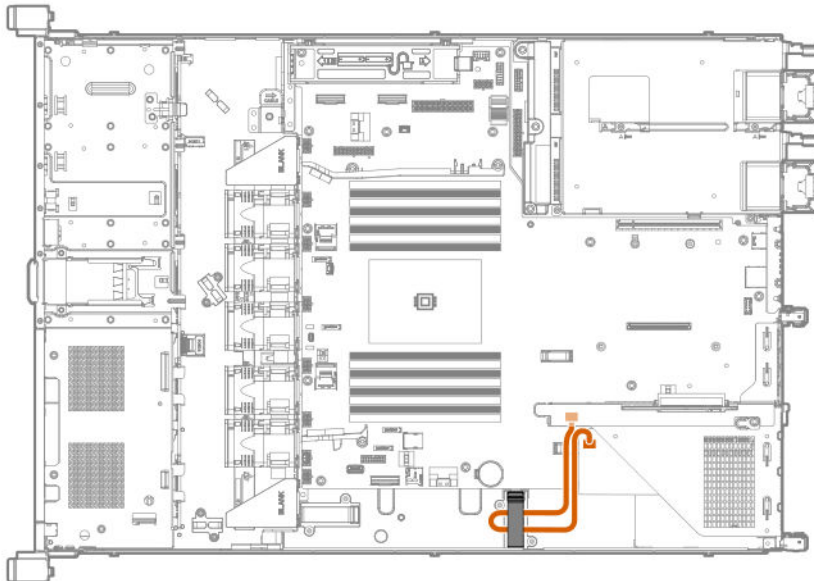

- Slot 2

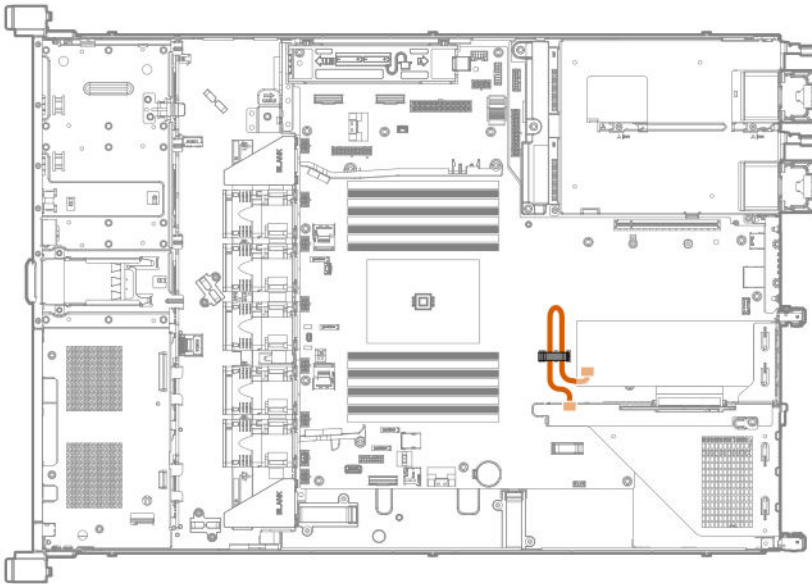

- Slot 3

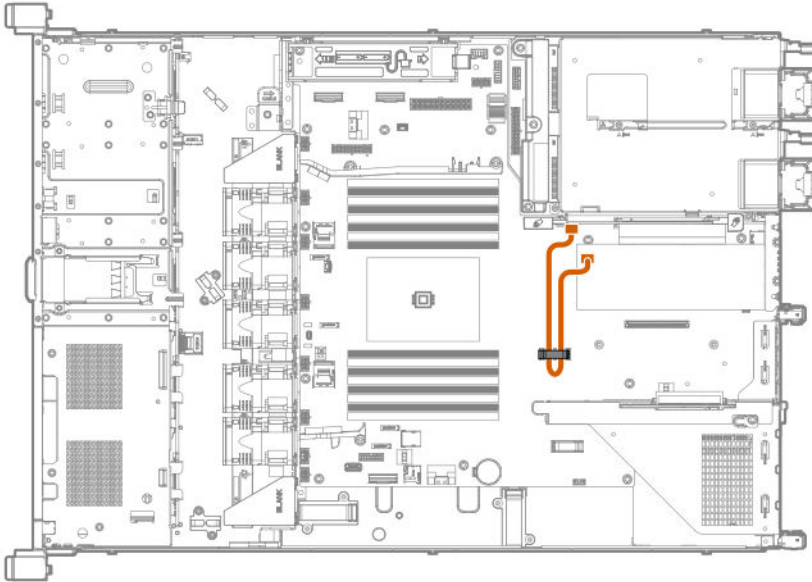

# Cable routing: Energy pack

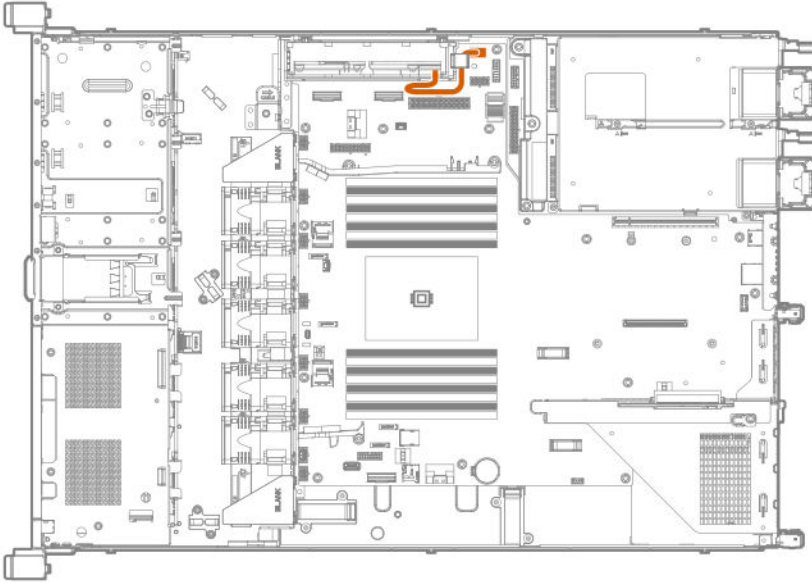



# Software and configuration utilities

## Server mode

The software and configuration utilities presented in this section operate in online mode, offline mode, or in both modes.

Software or configuration utility	Server mode
<b>Active Health System</b> on page 121	Online and Offline
<b>HPE iLO 5</b> on page 122	Online and Offline
<b>HPE Smart Storage Administrator</b> on page 128	Online and Offline
<b>iLO RESTful API</b> on page 123	Online and Offline
<b>Intelligent Provisioning</b> on page 124	Online and Offline
<b>Scripting Toolkit for Windows and Linux</b> on page 126	Online
<b>Service Pack for ProLiant</b> on page 130	Online and Offline
<b>Smart Update Manager</b> on page 130	Online and Offline
<b>UEFI System Utilities</b> on page 126	Offline

## Product QuickSpecs

For more information about product features, specifications, options, configurations, and compatibility, see the product QuickSpecs on the Hewlett Packard Enterprise website (<http://www.hpe.com/info/qs>).

## Active Health System Viewer

Active Health System Viewer (AHSV) is an online tool used to read, diagnose, and resolve server issues quickly using AHS uploaded data. AHSV provides Hewlett Packard Enterprise recommended repair actions based on experience and best practices. AHSV provides the ability to:

- Read server configuration information
- View Driver/Firmware inventory
- Review Event Logs
- Respond to Fault Detection Analytics alerts
- Open new and update existing support cases

## Active Health System

The Active Health System monitors and records changes in the server hardware and system configuration.

The Active Health System provides:

- Continuous health monitoring of over 1600 system parameters
- Logging of all configuration changes
- Consolidated health and service alerts with precise time stamps
- Agentless monitoring that does not affect application performance

For more information about the Active Health System, see the iLO user guide at the following website: <http://www.hpe.com/support/ilo-docs>.

## Active Health System data collection

The Active Health System does not collect information about your operations, finances, customers, employees, or partners.

Examples of information that is collected:

- Server model and serial number
- Processor model and speed
- Storage capacity and speed
- Memory capacity and speed
- Firmware/BIOS and driver versions and settings

The Active Health System does not parse or change OS data from third-party error event log activities (for example, content created or passed through the OS).

## Active Health System Log

The data collected by the Active Health System is stored in the Active Health System Log. The data is logged securely, isolated from the operating system, and separate from customer data. Host resources are not consumed in the collection and logging of Active Health System data.

When the Active Health System Log is full, new data overwrites the oldest data in the log.

It takes less than 5 minutes to download the Active Health System Log and send it to a support professional to help you resolve an issue.

When you download and send Active Health System data to Hewlett Packard Enterprise, you agree to have the data used for analysis, technical resolution, and quality improvements. The data that is collected is managed according to the privacy statement, available at <http://www.hpe.com/info/privacy>.

## HPE iLO 5

iLO 5 is a remote server management processor embedded on the system boards of HPE ProLiant servers and Synergy compute modules. iLO enables the monitoring and controlling of servers from remote locations. iLO management is a powerful tool that provides multiple ways to configure, update, monitor, and repair servers remotely. iLO (Standard) comes preconfigured on Hewlett Packard Enterprise servers without an additional cost or license.

Features that enhance server administrator productivity and additional new security features are licensed. For more information, see the iLO licensing guide at the following website: <http://www.hpe.com/support/ilo-docs>.

For more information about iLO, see the iLO user guide at the following website: <http://www.hpe.com/support/ilo-docs>.

## iLO Federation

iLO Federation enables you to manage multiple servers from one system using the iLO web interface.

When configured for iLO Federation, iLO uses multicast discovery and peer-to-peer communication to enable communication between the systems in iLO Federation groups.

When you navigate to one of the iLO Federation pages, a data request is sent from the iLO system running the web interface to its peers, and from those peers to other peers until all data for the selected iLO Federation group is retrieved.

iLO supports the following features:

- Group health status—View server health and model information.
- Group virtual media—Connect URL-based media for access by a group of servers.
- Group power control—Manage the power status of a group of servers.
- Group power capping—Set dynamic power caps for a group of servers.
- Group firmware update—Update the firmware of a group of servers.
- Group license installation—Enter a license key to activate iLO licensed features on a group of servers.
- Group configuration—Add iLO Federation group memberships for multiple iLO systems.

Any user can view information on iLO Federation pages, but a license is required for using the following features: Group virtual media, Group power control, Group power capping, Group configuration, and Group firmware update.

For more information about iLO Federation, see the iLO user guide at the following website: <http://www.hpe.com/support/ilo-docs>.

## iLO Service Port

To find out if your server or compute module supports this feature, see the server specifications document at the following website: <http://www.hpe.com/info/qs>.

When you have physical access to a server, you can use the Service Port to do the following:

Download the Active Health System Log to a supported USB flash drive.

When you use this feature, the connected USB flash drive is not accessible by the host operating system.

When you use the iLO Service Port:

- Actions are logged in the iLO event log.
- The server UID flashes to indicate the Service Port status.  
You can also retrieve the Service Port status by using a REST client and the iLO RESTful API.
- You cannot use the Service Port to boot any device within the server, or the server itself.
- You cannot access the server by connecting to the Service Port.
- You cannot access the connected device from the server.

For more information about the iLO Service Port, see the iLO user guide at the following website: <http://www.hpe.com/support/ilo-docs>.

## iLO RESTful API

iLO includes the iLO RESTful API, which is Redfish API conformant. The iLO RESTful API is a management interface that server management tools can use to perform configuration, inventory, and monitoring tasks by sending basic HTTPS operations (GET, PUT, POST, DELETE, and PATCH) to the iLO web server.

To learn more about the iLO RESTful API, see the Hewlett Packard Enterprise website (<http://www.hpe.com/support/restfulinterface/docs>).

For specific information about automating tasks using the iLO RESTful API, see libraries and sample code at <http://www.hpe.com/info/redfish>.

## RESTful Interface Tool

The RESTful Interface Tool (iLOREST) is a scripting tool that allows you to automate HPE server management tasks. It provides a set of simplified commands that take advantage of the iLO RESTful API. You can install the tool on your computer for remote use or install it locally on a server with a Windows or Linux Operating System. The RESTful Interface Tool offers an interactive mode, a scriptable mode, and a file-based mode similar to CONREP to help decrease automation times.

For more information, see the following website: <http://www.hpe.com/info/resttool>.

## iLO Amplifier Pack

The iLO Amplifier Pack is an advanced server inventory, firmware and driver update solution that enables rapid discovery, detailed inventory reporting, firmware, and driver updates by leveraging iLO advanced functionality. The iLO Amplifier Pack performs rapid server discovery and inventory for thousands of supported servers for the purpose of updating firmware and drivers at scale.

For more information about iLO Amplifier Pack, see the *iLO Amplifier Pack User Guide* at the following website: <http://www.hpe.com/support/ilo-ap-ug-en>.

## Integrated Management Log

The IML records hundreds of events and stores them in an easy-to-view form. The IML timestamps each event with one-minute granularity.

You can view recorded events in the IML in several ways, including the following:

- From within HPE SIM
- From within the UEFI System Utilities
- From within the Embedded UEFI shell
- From within the iLO web interface

## Intelligent Provisioning

Intelligent Provisioning is a single-server deployment tool embedded in ProLiant servers and HPE Synergy compute modules. Intelligent Provisioning simplifies server setup, providing a reliable and consistent way to deploy servers.

Intelligent Provisioning 3.30 and later includes HPE Rapid Setup Software. When you launch F10 mode from the POST screen, you are prompted to select whether you want to enter the Intelligent Provisioning or HPE Rapid Setup Software mode.

---

**NOTE:** After you have selected a mode, you must reprovision the server to change the mode that launches when you boot to F10.

---

Intelligent Provisioning prepares the system for installing original, licensed vendor media and Hewlett Packard Enterprise-branded versions of OS software. Intelligent Provisioning also prepares the system to integrate optimized server support software from the Service Pack for ProLiant (SPP). SPP is a comprehensive systems software and firmware solution for ProLiant servers, server blades, their enclosures, and HPE Synergy compute modules. These components are preloaded with a basic set of firmware and OS components that are installed along with Intelligent Provisioning.

- 
- !** **IMPORTANT:** HPE ProLiant DX/XL servers do not support operating system installation with Intelligent Provisioning, but they do support the maintenance features. For more information, see "Performing Maintenance" in the Intelligent Provisioning user guide and online help.
- 

After the server is running, you can update the firmware to install additional components. You can also update any components that have been outdated since the server was manufactured.

To access Intelligent Provisioning:

- Press **F10** from the POST screen and enter either Intelligent Provisioning or HPE Rapid Setup Software.
- From the iLO web interface using **Always On**. **Always On** allows you to access Intelligent Provisioning without rebooting your server.

## Intelligent Provisioning operation

Intelligent Provisioning includes the following components:

- Critical boot drivers
- Active Health System (AHS)
- Erase Utility
- Deployment Settings

- 
- !** **IMPORTANT:**
- Although your server is preloaded with firmware and drivers, Hewlett Packard Enterprise recommends updating the firmware upon initial setup. Also, downloading and updating the latest version of Intelligent Provisioning ensures the latest supported features are available.
  - For ProLiant servers, firmware is updated using the Intelligent Provisioning Firmware Update utility.
  - Do not update firmware if the version you are currently running is required for compatibility.
- 

**NOTE:** Intelligent Provisioning does not function within multihomed configurations. A multihomed host is one that is connected to two or more networks or has two or more IP addresses.

---

Intelligent Provisioning provides installation help for the following operating systems:

- Microsoft Windows Server
- Red Hat Enterprise Linux
- SUSE Linux Enterprise Server
- VMware ESXi/vSphere Custom Image
- ClearOS

Not all versions of an OS are supported. For information about specific versions of a supported operating system, see the OS Support Matrix on the Hewlett Packard Enterprise website (<http://www.hpe.com/info/ossupport>).

## Management Security

HPE ProLiant Gen10 servers are built with some of the industry's most advanced security capabilities, out of the box, with a foundation of secure embedded management applications and firmware. The management security provided by HPE

embedded management products enables secure support of modern workloads, protecting your components from unauthorized access and unapproved use. The range of embedded management and optional software and firmware available with the iLO Advanced license provides security features that help ensure protection, detection, and recovery from advanced cyber-attacks. For more information, see the *HPE Gen10 Server Security Reference Guide* on the Hewlett Packard Enterprise Information Library at <http://www.hpe.com/support/gen10-security-ref-en>.

## Scripting Toolkit for Windows and Linux

The STK for Windows and Linux is a server deployment product that delivers an unattended automated installation for high-volume server deployments. The STK is designed to support ProLiant servers. The toolkit includes a modular set of utilities and important documentation that describes how to apply these tools to build an automated server deployment process.

The STK provides a flexible way to create standard server configuration scripts. These scripts are used to automate many of the manual steps in the server configuration process. This automated server configuration process cuts time from each deployment, making it possible to scale rapid, high-volume server deployments.

For more information or to download the STK, see the [Hewlett Packard Enterprise website](#).

## UEFI System Utilities

The UEFI System Utilities is embedded in the system ROM. Its features enable you to perform a wide range of configuration activities, including:

- Configuring system devices and installed options.
- Enabling and disabling system features.
- Displaying system information.
- Selecting the primary boot controller or partition.
- Configuring memory options.
- Launching other preboot environments.

HPE servers with UEFI can provide:

- Support for boot partitions larger than 2.2 TB. Such configurations could previously only be used for boot drives when using RAID solutions.
- Secure Boot that enables the system firmware, option card firmware, operating systems, and software collaborate to enhance platform security.
- UEFI Graphical User Interface (GUI)
- An Embedded UEFI Shell that provides a preboot environment for running scripts and tools.
- Boot support for option cards that only support a UEFI option ROM.

## Selecting the boot mode

This server provides two **Boot Mode** configurations: UEFI Mode and Legacy BIOS Mode. Certain boot options require that you select a specific boot mode. By default, the boot mode is set to **UEFI Mode**. The system must boot in **UEFI Mode** to use certain options, including:

- Secure Boot, UEFI Optimized Boot, Generic USB Boot, IPv6 PXE Boot, iSCSI Boot, and Boot from URL
- Fibre Channel/FCoE Scan Policy

---

**NOTE:** The boot mode you use must match the operating system installation. If not, changing the boot mode can impact the ability of the server to boot to the installed operating system.

---

### Prerequisite

When booting to **UEFI Mode**, leave **UEFI Optimized Boot** enabled.

### Procedure

1. From the **System Utilities** screen, select **System Configuration > BIOS/Platform Configuration (RBSU) > Boot Options > Boot Mode**.
2. Select a setting.
  - **UEFI Mode** (default)—Configures the system to boot to a UEFI compatible operating system.
  - **Legacy BIOS Mode**—Configures the system to boot to a traditional operating system in Legacy BIOS compatibility mode.
3. Save your setting.
4. Reboot the server.

## Secure Boot

Secure Boot is a server security feature that is implemented in the BIOS and does not require special hardware. Secure Boot ensures that each component launched during the boot process is digitally signed and that the signature is validated against a set of trusted certificates embedded in the UEFI BIOS. Secure Boot validates the software identity of the following components in the boot process:

- UEFI drivers loaded from PCIe cards
- UEFI drivers loaded from mass storage devices
- Preboot UEFI Shell applications
- OS UEFI boot loaders

When Secure Boot is enabled:

- Firmware components and operating systems with boot loaders must have an appropriate digital signature to execute during the boot process.
- Operating systems must support Secure Boot and have an EFI boot loader signed with one of the authorized keys to boot. For more information about supported operating systems, see <http://www.hpe.com/servers/ossupport>.

You can customize the certificates embedded in the UEFI BIOS by adding or removing your own certificates, either from a management console directly attached to the server, or by remotely connecting to the server using the iLO Remote Console.

You can configure Secure Boot:

- Using the **System Utilities** options described in the following sections.
- Using the iLO RESTful API to clear and restore certificates. For more information, see the Hewlett Packard Enterprise website (<http://www.hpe.com/info/redfish>).
- Using the `secboot` command in the Embedded UEFI Shell to display Secure Boot databases, keys, and security reports.

## Launching the Embedded UEFI Shell

Use the **Embedded UEFI Shell** option to launch the Embedded UEFI Shell. The Embedded UEFI Shell is a preboot command-line environment for scripting and running UEFI applications, including UEFI boot loaders. The Shell also provides CLI-based commands you can use to obtain system information, and to configure and update the system BIOS.

### Prerequisites

**Embedded UEFI Shell** is set to **Enabled**.

### Procedure

1. From the **System Utilities** screen, select **Embedded Applications > Embedded UEFI Shell**.

The **Embedded UEFI Shell** screen appears.

2. Press any key to acknowledge that you are physically present.

This step ensures that certain features, such as disabling **Secure Boot** or managing the **Secure Boot** certificates using third-party UEFI tools, are not restricted.

3. If an administrator password is set, enter it at the prompt and press **Enter**.

The `Shell>` prompt appears.

4. Enter the commands required to complete your task.

5. Enter the `exit` command to exit the Shell.

## HPE Smart Storage Administrator

HPE SSA is the main tool for configuring arrays on HPE Smart Array SR controllers. It exists in three interface formats: the HPE SSA GUI, the HPE SSA CLI, and HPE SSA Scripting. All formats provide support for configuration tasks. Some of the advanced tasks are available in only one format.

The diagnostic features in HPE SSA are also available in the standalone software HPE Smart Storage Administrator Diagnostics Utility CLI.

During the initial provisioning of the server or compute module, an array is required to be configured before the operating system can be installed. You can configure the array using SSA.

HPE SSA is accessible both offline (either through HPE Intelligent Provisioning or as a standalone bootable ISO image) and online:

- Accessing HPE SSA in the offline environment

---

**!** **IMPORTANT:** If you are updating an existing server in an offline environment, obtain the latest version of HPE SSA through Service Pack for ProLiant before performing configuration procedures.

---

Using one of multiple methods, you can run HPE SSA before launching the host operating system. In offline mode, users can configure or maintain detected and supported devices, such as optional Smart Array controllers and



integrated Smart Array controllers. Some HPE SSA features are only available in the offline environment, such as setting the boot controller and boot volume.

- Accessing HPE SSA in the online environment

This method requires an administrator to download the HPE SSA executables and install them. You can run HPE SSA online after launching the host operating system.

For more information, see *HPE Smart Array SR Gen10 Configuration Guide* at the [Hewlett Packard Enterprise website](#).

## HPE InfoSight for servers

The HPE InfoSight portal is a secure web interface hosted by HPE that allows you to monitor supported devices through a graphical interface.

HPE InfoSight for servers:

- Combines the machine learning and predictive analytics of HPE InfoSight with the health and performance monitoring of Active Health System (AHS) and HPE iLO to optimize performance and predict and prevent problems
- Provides automatic collection and analysis of the sensor and telemetry data from AHS to derive insights from the behaviors of the install base to provide recommendations to resolve problems and improve performance

For more information on getting started and using HPE InfoSight for servers, go to: <http://www.hpe.com/info/infosight-servers-docs>.

## USB support

Hewlett Packard Enterprise Gen10 servers support all USB operating speeds depending on the device that is connected to the server.

### External USB functionality

Hewlett Packard Enterprise provides external USB support to enable local connection of USB devices for server administration, configuration, and diagnostic procedures.

For additional security, external USB functionality can be disabled through USB options in UEFI System Utilities.

## Redundant ROM support

The server enables you to upgrade or configure the ROM safely with redundant ROM support. The server has a single ROM that acts as two separate ROM images. In the standard implementation, one side of the ROM contains the current ROM program version, while the other side of the ROM contains a backup version.

---

**NOTE:** The server ships with the same version programmed on each side of the ROM.

---

### Safety and security benefits

When you flash the system ROM, the flashing mechanism writes over the backup ROM and saves the current ROM as a backup, enabling you to switch easily to the alternate ROM version if the new ROM becomes corrupted for any reason. This feature protects the existing ROM version, even if you experience a power failure while flashing the ROM.

## Keeping the system current

### Updating firmware or system ROM

To update firmware or system ROM, use one of the following methods:

- The **Firmware Update** option in the System Utilities.
- The `fwupdate` command in the **Embedded UEFI Shell**.
- Service Pack for ProLiant (SPP)
- HPE online flash components
- Moonshot Component Pack

## Service Pack for ProLiant

SPP is a systems software and firmware solution delivered as a single ISO file download. This solution uses SUM as the deployment tool and is tested and supports HPE ProLiant, HPE BladeSystem, HPE Synergy, and HPE Apollo servers and infrastructure.

SPP, along with SUM and iSUT, provides Smart Update system maintenance tools that systematically update HPE ProLiant, HPE BladeSystem, HPE Synergy, and HPE Apollo servers and infrastructure.

SPP can be used in an online mode on a server running Windows, Linux, or VMware vSphere ESXi, or in an offline mode where the server is booted to an operating system included in the ISO file.

The preferred method for downloading an SPP is using the SPP Custom Download at <https://www.hpe.com/servers/spp/custom>.

The SPP is also available for download from the SPP download page at <https://www.hpe.com/servers/spp/download>.

## Smart Update Manager

SUM is an innovative tool for maintaining and updating the firmware, drivers, and system software of HPE ProLiant, HPE BladeSystem, HPE Synergy, and HPE Apollo servers, infrastructure, and associated options.

SUM identifies associated nodes you can update at the same time to avoid interdependency issues.

Key features of SUM include:

- Discovery engine that finds installed versions of hardware, firmware, and software on nodes.
- SUM deploys updates in the correct order and ensures that all dependencies are met before deploying an update.
- Interdependency checking.
- Automatic and step-by-step Localhost Guided Update process.
- Web browser-based user interface.
- Ability to create custom baselines and ISOs.
- Support for iLO Repository (Gen10 iLO 5 nodes only).
- Simultaneous firmware and software deployment for multiple remote nodes.
- Local offline firmware deployments with SPP deliverables.
- Extensive logging in all modes.

---

**NOTE:** SUM does not support third-party controllers, including flashing hard drives behind the controllers.

---

## Integrated Smart Update Tools

Integrated Smart Update Tools (iSUT) is a software utility used with iLO 4, iLO 5, iLO Amplifier Pack, HPE OneView, Service Pack for ProLiant (SPP), and Smart Update Manager (SUM) to stage, install, and activate firmware and driver updates.

- **iSUT**: Polls iLO to check for requests from HPE OneView, SUM, or iLO Amplifier Pack for updates through the management network and orchestrates staging, deploying, and activating updates. You can adjust the polling interval by issuing the appropriate command-line option provided by iSUT. Performs inventory on target servers, stages deployment, deploys updates, and then reboots the servers.
- **iLO 5 with integrated Smart Update** (Gen10 servers only): Performs iLO Repository-based updates by downloading the components from iLO Repository when iLO Installation Queue has the components which can be updated by iSUT.
- **iLO Amplifier Pack**: Displays available updates for servers. Communicates with iSUT (or SUT 1.x) to initiate updates using the iLO Redfish interface. iSUT reports the status of updates to iLO Amplifier Pack via iLO Restful Interface.
- **HPE OneView**: Displays available updates for servers. Communicates with iSUT (or SUT 1.x) to initiate updates, reports the status on the **Firmware** section of the **Server Profile** page of HPE OneView. HPE OneView provides automated compliance reporting in the dashboard.
- **SPP**: A comprehensive systems software and firmware update solution, which is delivered as a single ISO image.
- **SUM**: A tool for firmware and driver maintenance for HPE ProLiant servers and associated options.

---

**NOTE:** SUM, iLO Amplifier Pack, and HPE OneView should not manage the same nodes.

---

## Updating firmware from the System Utilities

Use the **Firmware Updates** option to update firmware components in the system, including the system BIOS, NICs, and storage cards.

### Procedure

1. Access the System ROM Flash Binary component for your server from the Hewlett Packard Enterprise Support Center.
2. Copy the binary file to a USB media or iLO virtual media.
3. Attach the media to the server.
4. Launch the **System Utilities**, and select **Embedded Applications > Firmware Update**.
5. Select a device.

The **Firmware Updates** screen lists details about your selected device, including the current firmware version in use.

6. Select **Select Firmware File**.
7. Select the flash file in the **File Explorer** list.

The firmware file is loaded and the **Firmware Updates** screen lists details of the file in the **Selected firmware file** field.

8. Select **Image Description**, and then select a firmware image.

A device can have multiple firmware images.

9. Select **Start firmware update**.

## Updating the firmware from the UEFI Embedded Shell

### Procedure

1. Access the System ROM Flash Binary component for your server from the Hewlett Packard Enterprise Support Center (<http://www.hpe.com/support/hpesc>).
2. Copy the binary file to a USB media or iLO virtual media.
3. Attach the media to the server.
4. Boot to the UEFI Embedded Shell.
5. To obtain the assigned file system volume for the USB key, enter `map -r`.
6. Change to the file system that contains the System ROM Flash Binary component for your server. Enter one of the `fsx` file systems available, such as `fs0:` or `fs1:`, and press **Enter**.
7. Use the `cd` command to change from the current directory to the directory that contains the binary file.
8. Flash the system ROM by entering `fwupdate -d BIOS -f filename`.
9. Reboot the server. A reboot is required after the firmware update in order for the updates to take effect and for hardware stability to be maintained.

## Online Flash components

This component provides updated system firmware that can be installed directly on supported operating systems. Additionally, when used in conjunction with SUM, this Smart Component allows the user to update firmware on remote servers from a central location. This remote deployment capability eliminates the need for the user to be physically present at the server to perform a firmware update.

## Drivers

---

 **IMPORTANT:** Always perform a backup before installing or updating device drivers.

---

Update drivers using any of the following **Smart Update Solutions**:

- Download the latest Service Pack for ProLiant (includes Smart Update Manager)
- Create a custom SPP download
- Download Smart Update Manager for Linux
- Download specific drivers

To locate the drivers for a server, go to the **Hewlett Packard Enterprise Support Center website**, and then search for the product name/number.

## Software and firmware

Update software and firmware before using the server for the first time, unless any installed software or components require an older version.

For system software and firmware updates, use one of the following sources:

- Download the SPP from the Hewlett Packard Enterprise website (<http://www.hpe.com/servers/spp/download>).
- Download individual drivers, firmware, or other system software components from the server product page in the Hewlett Packard Enterprise Support Center website (<http://www.hpe.com/support/hpesc>).

## Operating system version support

For information about specific versions of a supported operating system, refer to the [operating system support matrix](#).

## HPE Pointnext Portfolio

HPE Pointnext delivers confidence, reduces risk, and helps customers realize agility and stability. Hewlett Packard Enterprise helps customers succeed through Hybrid IT by simplifying and enriching the on-premise experience, informed by public cloud qualities and attributes.

Operational Support Services enable you to choose the right service level, length of coverage, and response time to fit your business needs. For more information, see the Hewlett Packard Enterprise website:

<https://www.hpe.com/us/en/services/operational.html>

Utilize the Advisory and Transformation Services in the following areas:

- Private or hybrid cloud computing
- Big data and mobility requirements
- Improving data center infrastructure
- Better use of server, storage, and networking technology

For more information, see the Hewlett Packard Enterprise website:

<http://www.hpe.com/services/consulting>

## Proactive notifications

30 to 60 days in advance, Hewlett Packard Enterprise sends notifications to subscribed customers on upcoming:

- Hardware, firmware, and software changes
- Bulletins
- Patches
- Security alerts

You can subscribe to proactive notifications on the [Hewlett Packard Enterprise website](#).

# System battery replacement

## System battery information

The server contains an internal lithium manganese dioxide, a vanadium pentoxide, or an alkaline battery that provides power to the real-time clock. If this battery is not properly handled, a risk of the fire and burns exists. To reduce the risk of personal injury:

- Do not attempt to recharge the battery.
- Do not expose the battery to temperatures higher than 60°C (140°F).
- Do not disassemble, crush, puncture, short external contacts, or dispose the battery in fire or water.
- If the server no longer automatically displays the correct date and time, then replace the battery that provides power to the real-time clock. Under normal use, battery life is 5 to 10 years.

## Removing and replacing the system battery

### Procedure

1. If installed, **remove the front bezel.**
2. **Power down the server.**
3. Remove all power:
  - a. Disconnect each power cord from the power source
  - b. Disconnect each power cord from the server.
4. Do one of the following:
  - **Extend the server from the rack.**
  - **Remove the server from the rack.**
5. **Remove the access panel.**
6. **Locate the battery on the system board.**
7. Remove the battery.

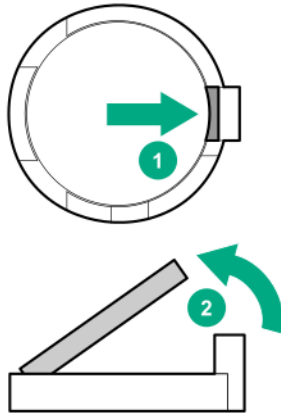

8. Insert the battery with the "+" side facing up on the socket, and then press the battery down to secure it in place.

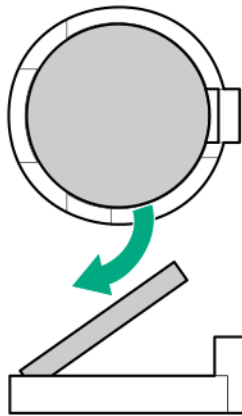

9. **Install the access panel.**
10. **Install the server into the rack.**
11. Connect all peripheral cables to the server.
12. Connect each power cord to the server.
13. Connect each power cord to the power source.
14. **Power up the server.**
15. Properly dispose of the old battery.

For more information about battery replacement or proper disposal, contact an authorized reseller or an authorized service provider.

# Troubleshooting

## NMI functionality

An NMI crash dump enables administrators to create crash dump files when a system is hung and not responding to traditional debugging methods.

An analysis of the crash dump log is an essential part of diagnosing reliability problems, such as hanging operating systems, device drivers, and applications. Many crashes freeze a system, and the only available action for administrators is to cycle the system power. Resetting the system erases any information that could support problem analysis, but the NMI feature preserves that information by performing a memory dump before a hard reset.

To force the OS to invoke the NMI handler and generate a crash dump log, the administrator can use the iLO Virtual NMI feature.

## Troubleshooting resources

Troubleshooting resources are available for HPE Gen10 server products in the following documents:

- *Troubleshooting Guide for HPE ProLiant Gen10 servers* provides procedures for resolving common problems and comprehensive courses of action for fault isolation and identification, issue resolution, and software maintenance.
- *Error Message Guide for HPE ProLiant Gen10 servers and HPE Synergy* provides a list of error messages and information to assist with interpreting and resolving error messages.
- *Integrated Management Log Messages and Troubleshooting Guide for HPE ProLiant Gen10 and HPE Synergy* provides IML messages and associated troubleshooting information to resolve critical and cautionary IML events.

To access the troubleshooting resources, see the Hewlett Packard Enterprise Information Library (<http://www.hpe.com/info/gen10-troubleshooting>).



# Safety, warranty, and regulatory information

## Regulatory information

To view the regulatory information for your product, view the *Safety and Compliance Information for Server, Storage, Power, Networking, and Rack Products*, available at the Hewlett Packard Enterprise Support Center:

[www.hpe.com/support/Safety-Compliance-EnterpriseProducts](http://www.hpe.com/support/Safety-Compliance-EnterpriseProducts)

### Additional regulatory information

Hewlett Packard Enterprise is committed to providing our customers with information about the chemical substances in our products as needed to comply with legal requirements such as REACH (Regulation EC No 1907/2006 of the European Parliament and the Council). A chemical information report for this product can be found at:

[www.hpe.com/info/reach](http://www.hpe.com/info/reach)

For Hewlett Packard Enterprise product environmental and safety information and compliance data, including RoHS and REACH, see:

[www.hpe.com/info/ecodata](http://www.hpe.com/info/ecodata)

For Hewlett Packard Enterprise environmental information, including company programs, product recycling, and energy efficiency, see:

[www.hpe.com/info/environment](http://www.hpe.com/info/environment)

## Notices for Eurasian Economic Union



### Manufacturer and Local Representative Information

#### Manufacturer information:

Hewlett Packard Enterprise, 6280 America Center Drive, San Jose, CA 95002 U.S.

#### Local representative information Russian:

- **Russia**

ООО "Хьюлетт Паккард Энтерпрайз", Российская Федерация, 125171, г. Москва, Ленинградское шоссе, 16А, стр.3, Телефон: +7 499 403 4248 Факс: +7 499 403 4677

- **Kazakhstan**

ТОО «Хьюлетт-Паккард (К)», Республика Казахстан, 050040, г. Алматы, Бостандыкский район, проспект Аль-Фараби, 77/7, Телефон/факс: + 7 727 355 35 50

#### Local representative information Kazakh:

- **Russia**

ЖШС "Хьюлетт Паккард Энтерпрайз", Ресей Федерациясы, 125171, Мәскеу, Ленинград тас жолы, 16А блок 3, Телефон: +7 499 403 4248 Факс: +7 499 403 4677

- **Kazakhstan**

ЖШС «Хьюлетт-Паккард (К)», Қазақстан Республикасы, 050040, Алматы қ., Бостандық ауданы, Әл-Фараби даңғылы, 77/7, Телефон/факс: +7 727 355 35 50

**Manufacturing date:**

The manufacturing date is defined by the serial number.

CCSYWWZZZZ (product serial number format)

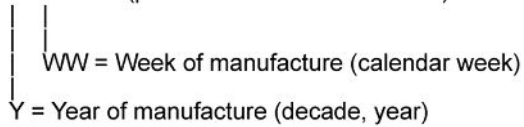

If you need help identifying the manufacturing date, contact [tre@hpe.com](mailto:tre@hpe.com).

**Turkey RoHS material content declaration**

Türkiye Cumhuriyeti: AEEE Yönetmeliğine Uygundur

**Ukraine RoHS material content declaration**

Обладнання відповідає вимогам Технічного регламенту щодо обмеження використання деяких небезпечних речовин в електричному та електронному обладнанні, затвердженого постановою Кабінету Міністрів України від 3 грудня 2008 № 1057

**Warranty information**

To view the warranty information for your product, see the links provided below:

**HPE ProLiant and IA-32 Servers and Options**

[www.hpe.com/support/ProLiantServers-Warranties](http://www.hpe.com/support/ProLiantServers-Warranties)

**HPE Enterprise and Cloudline Servers**

[www.hpe.com/support/EnterpriseServers-Warranties](http://www.hpe.com/support/EnterpriseServers-Warranties)

**HPE Storage Products**

[www.hpe.com/support/Storage-Warranties](http://www.hpe.com/support/Storage-Warranties)

**HPE Networking Products**

[www.hpe.com/support/Networking-Warranties](http://www.hpe.com/support/Networking-Warranties)

# Specifications

## Environmental specifications

Specifications	Value
<b>Temperature range*</b>	—
Operating	10°C to 35°C (50°F to 95°F)
Nonoperating	-30°C to 60°C (-22°F to 140°F)
<b>Relative humidity (noncondensing)</b>	—
Operating	8% to 90% - Relative humidity (Rh), 28°C (82.4°F) maximum wet bulb temperature, non-condensing
Nonoperating	5 to 95% relative humidity (Rh), 38.7°C (101.7°F) maximum wet bulb temperature, non-condensing
<b>Altitude</b>	—
Operating	3050 m (10,000 ft). This value may be limited by the type and number of options installed. Maximum allowable altitude change rate is 457 m/min (1500 ft/min).
Non-operating	9144 m (30,000 ft). Maximum allowable altitude change rate is 457 m/min (1500 ft/min).

### Standard operating support

10° to 35°C (50° to 95°F) at sea level with an altitude derating of 1.0°C per every 305 m (1.8°F per every 1000 ft) above sea level to a maximum of 3050 m (10,000 ft), no direct sustained sunlight. Maximum rate of change is 20°C/hr (36°F/hr). The upper limit and rate of change may be limited by the type and number of options installed.

System performance during standard operating support may be reduced if operating with a fan fault or above 30°C (86°F).

### Extended ambient operating support

For approved hardware configurations, the supported system inlet range is extended to be: 5° to 10°C (41° to 50°F) and 35° to 40°C (95° to 104°F) at sea level with an altitude derating of 1.0°C per every 175 m (1.8°F per every 574 ft) above 900 m (2953 ft) to a maximum of 3050 m (10,000 ft). The approved hardware configurations for this system are listed at the [Hewlett Packard Enterprise website](#).

40°C to 45°C (104°F to 113°F) at sea level with an altitude derating of 1.0°C per every 125 m (1.8°F per every 410 ft) above 900 m (2953 ft) to a maximum of 3050 m (10,000 ft). The approved hardware configurations for this system are listed on the [Hewlett Packard Enterprise website](#).

System performance may be reduced if operating in the extended ambient operating range or with a fan fault.

## Mechanical specifications

Specification	Value
Height	4.29 cm (1.69 in)
Depth	61.49 cm (24.21 in)
Width	43.46 cm (17.11 in)
Weight (approximate range)	10.0 kg to 16.0 kg (22.05 lb to 35.27 lb)

## Power supply specifications

Depending on the installed options and the regional location where the server was purchased, the server can be configured with one of the following power supplies:

- **HPE 500W Low Halogen Non-hot-plug Power Supply**
- **HPE 500W Flex Slot Platinum Hot-plug Low Halogen Power Supply** on page 141
- **HPE 800W Flex Slot Platinum Hot-plug Low Halogen Power Supply** on page 142
- **HPE 800W Flex Slot Titanium Hot-plug Low Halogen Power Supply** on page 143
- **HPE 800W Flex Slot Universal Hot-plug Low Halogen Power Supply** on page 144
- **HPE 800W Flex Slot -48VDC Hot-plug Low Halogen Power Supply** on page 144
- **HPE 1600W Flex Slot Platinum Hot-plug Low Halogen Power Supply** on page 146

For detailed power supply specifications, see the QuickSpecs on the [Hewlett Packard Enterprise website](#).

### HPE 500W Low Halogen Non-hot-plug Power Supply

Specification	Value
<b>Input requirements</b>	—
Rated input voltage	100 VAC to 240 VAC 240 VDC for China only
Rated input frequency	50 Hz to 60 Hz
Rated input current	5.8 A at 100 VAC 2.3 A at 240 VAC 2.7 A at 240 VDC for China only
Maximum rated input power	578 W at 100 VAC 557 W at 240 VAC
BTUs per hour	1953 at 100 VAC 1882 at 240 VAC

*Table Continued*

<b>Specification</b>	<b>Value</b>
<b>Power supply output</b>	—
Rated steady-state power	500 W at 100 VAC to 240 VAC input 500 W at 240 VDC input for China only
Maximum peak power	500 W at 100 VAC to 240 VAC input 500 W at 240 VDC input for China only

## **HPE 500W Flex Slot Platinum Hot-plug Low Halogen Power Supply**

<b>Specification</b>	<b>Value</b>
<b>Input requirements</b>	—
Rated input voltage	100 VAC to 240 VAC 240 VDC for China only
Rated input frequency	50 Hz to 60 Hz Not applicable to 240 VDC
Rated input current	5.8 A at 100 VAC 2.8 A at 200 VAC 2.4 A at 240 VDC for China only
Maximum rated input power	557 W at 100 VAC 539 W at 200 VAC 537 W at 240 VDC for China only
BTUs per hour	1902 at 100 VAC 1840 at 200 VAC 1832 at 240 VDC for China only
<b>Power supply output</b>	—

*Table Continued*

<b>Specification</b>	<b>Value</b>
Rated steady-state power	500 W at 100 VAC to 127 VAC input
	500 W at 100 VAC to 240 VAC input
	500 W at 240 VDC input for China only
Maximum peak power	500 W at 100 VAC to 127 VAC input
	500 W at 100 VAC to 240 VAC input
	500 W at 240 VDC input for China only

## **HPE 800W Flex Slot Platinum Hot-plug Low Halogen Power Supply**

<b>Specification</b>	<b>Value</b>
<b>Input requirements</b>	—
Rated input voltage	100 VAC to 127 VAC
	200 VAC to 240 VAC
	240 VDC for China only
Rated input frequency	50 Hz to 60 Hz
	Not applicable to 240 VDC
Rated input current	9.1 A at 100 VAC
	4.4 A at 200 VAC
	3.6 A at 240 VDC for China only
Maximum rated input power	899 W at 100 VAC
	867 W at 200 VAC
	864 W at 240 VDC for China only
BTUs per hour	3067 at 100 VAC
	2958 at 200 VAC
	2949 at 240 VAC for China only
<b>Power supply output</b>	—

*Table Continued*

Specification	Value
Rated steady-state power	800 W at 100 VAC to 127 VAC input
	800 W at 100 VAC to 240 VAC input
	800 W at 240 VDC input for China only
Maximum peak power	800 W at 100 VAC to 127 VAC input
	800 W at 100 VAC to 240 VAC input
	800 W at 240 VDC input for China only

## HPE 800W Flex Slot Titanium Hot-plug Low Halogen Power Supply

Specification	Value
<b>Input requirements</b>	—
Rated input voltage	200 VAC to 240 VAC
	240 VDC for China only
Rated input frequency	50 Hz to 60 Hz
	Not applicable to 240 VDC
Rated input current	4.35 A at 200 VAC 3.62 A at 240 VAC
	3.62 A at 240 VDC for China only
Maximum rated input power	851 W at 200 VAC
	848 W at 240 VAC
	848 W at 240 VDC for China only
BTUs per hour	2905 at 200 VAC
	2893 at 240 VAC
	2893 at 240 VDC for China only
<b>Power supply output</b>	—
Rated steady-state power	800 W at 200 VAC to 240 VAC input
	800 W at 240 VDC input for China only
Maximum peak power	800 W at 200 VAC to 240 VAC input
	800 W at 240 VDC input for China only

## HPE 800W Flex Slot Universal Hot-plug Low Halogen Power Supply

Specification	Value
<b>Input requirements</b>	—
Rated input voltage	200 VAC to 277 VAC 380 VDC
Rated input frequency	50 Hz to 60 Hz
Rated input current	4.4 A at 200 VAC 3.1 A at 277 VAC 2.3 A at 380 VDC
Maximum rated input power	869 W at 200 VAC 865 W at 230 VAC 861 W at 277 VAC 863 W at 380 VDC
BTUs per hour	2964 at 200 VAC 2951 at 230 VAC 2936 at 277 VAC 2943 at 380 VDC
<b>Power supply output</b>	—
Rated steady-state power	800 W at 200 VAC to 277 VAC input
Maximum peak power	800 W at 200 VAC to 277 VAC input

## HPE 800W Flex Slot -48VDC Hot-plug Low Halogen Power Supply

Specification	Value
<b>Input requirements</b>	—
Rated input voltage	-40 VDC to -72 VDC -48 VDC nominal input
Rated input current	22.1 A at -40 VDC input 18.2 A at -48 VDC input, nominal input 12.0 A at -72 VDC input

Table Continued



Specification	Value
Rated input power (W)	874 W at -40 VDC input
	865 W at -48 VDC input, nominal input
	854 W at -72 VDC input
Rated input power (BTUs per hour)	2983 at -40 VDC input
	2951 at -48 VDC input, nominal input
	2912 at -72 VDC input
<b>Power supply output</b>	—
Rated steady-state power (W)	800 W at -40 VDC to -72 VDC
Maximum peak power (W)	800 W at -40 VDC to -72 VDC
Maximum peak power	800 W at -40 VDC to -72 VDC input



**WARNING:** To reduce the risk of electric shock or energy hazards:

- This equipment must be installed by trained service personnel.
- Connect the equipment to a reliably grounded secondary circuit source. A secondary circuit has no direct connection to a primary circuit and derives its power from a transformer, converter, or equivalent isolation device.
- The branch circuit overcurrent protection must be rated 27 A.



**CAUTION:** This equipment is designed to permit the connection of the earthed conductor of the DC supply circuit to the earthing conductor at the equipment.

If this connection is made, all of the following must be met:

- This equipment must be connected directly to the DC supply system earthing electrode conductor or to a bonding jumper from an earthing terminal bar or bus to which the DC supply system earthing electrode conductor is connected.
- This equipment must be located in the same immediate area (such as adjacent cabinets) as any other equipment that has a connection between the earthed conductor of the same DC supply circuit and the earthing conductor, and also the point of earthing of the DC system. The DC system must be earthed elsewhere.
- The DC supply source is to be located within the same premises as the equipment.
- Switching or disconnecting devices must not be in the earthed circuit conductor between the DC source and the point of connection of the earthing electrode conductor.

## HPE 1600W Flex Slot Platinum Hot-plug Low Halogen Power Supply

<b>Specification</b>	<b>Value</b>
<b>Input requirements</b>	
Rated input voltage	200 VAC to 240 VAC
	240 VDC for China only
Rated input frequency	50 Hz to 60 Hz
Rated input current	8.7 A at 200 VAC
	7.2 A at 240 VAC
Maximum rated input power	1734 W at 200 VAC
	1725 W at 240 VAC
BTUs per hour	5918 at 200 VAC
	5884 at 240 VAC
<b>Power supply output</b>	
Rated steady-state power	1600 W at 200 VAC to 240 VAC input
	1600 W at 240 VDC input
Maximum peak power	2200 W for 1 ms (turbo mode) at 200 VAC to 240 VAC input

# Websites

## General websites

### Hewlett Packard Enterprise Information Library

[www.hpe.com/info/EIL](http://www.hpe.com/info/EIL)

### Subscription Service/Support Alerts

[www.hpe.com/support/e-updates](http://www.hpe.com/support/e-updates)

### Single Point of Connectivity Knowledge (SPOCK) Storage compatibility matrix

[www.hpe.com/storage/spock](http://www.hpe.com/storage/spock)

### Storage white papers and analyst reports

[www.hpe.com/storage/whitepapers](http://www.hpe.com/storage/whitepapers)

For additional general support websites, see [\*\*Support and other resources\*\*](#).

## Product websites

### HPE ProLiant DL325 Gen10 Server QuickSpecs

<http://www.hpe.com/servers/dl325-gen10>

### HPE ProLiant DL325 Gen10 Server support page

<http://www.hpe.com/support/dl325gen10>

### HPE ProLiant DL325 Gen10 Server user documents

<http://www.hpe.com/info/dl325gen10-docs>

# Support and other resources

## Accessing Hewlett Packard Enterprise Support

- For live assistance, go to the Contact Hewlett Packard Enterprise Worldwide website:  
<http://www.hpe.com/info/assistance>
- To access documentation and support services, go to the Hewlett Packard Enterprise Support Center website:  
<http://www.hpe.com/support/hpesc>

### Information to collect

- Technical support registration number (if applicable)
- Product name, model or version, and serial number
- Operating system name and version
- Firmware version
- Error messages
- Product-specific reports and logs
- Add-on products or components
- Third-party products or components

## Accessing updates

- Some software products provide a mechanism for accessing software updates through the product interface. Review your product documentation to identify the recommended software update method.

- To download product updates:

### Hewlett Packard Enterprise Support Center

[www.hpe.com/support/hpesc](http://www.hpe.com/support/hpesc)

### Hewlett Packard Enterprise Support Center: Software downloads

[www.hpe.com/support/downloads](http://www.hpe.com/support/downloads)

### Software Depot

[www.hpe.com/support/softwaredepot](http://www.hpe.com/support/softwaredepot)

- To subscribe to eNewsletters and alerts:

[www.hpe.com/support/e-updates](http://www.hpe.com/support/e-updates)

- To view and update your entitlements, and to link your contracts and warranties with your profile, go to the Hewlett Packard Enterprise Support Center **More Information on Access to Support Materials** page:

[www.hpe.com/support/AccessToSupportMaterials](http://www.hpe.com/support/AccessToSupportMaterials)

- 
-  **IMPORTANT:** Access to some updates might require product entitlement when accessed through the Hewlett Packard Enterprise Support Center. You must have an HPE Passport set up with relevant entitlements.
-

## Customer self repair

Hewlett Packard Enterprise customer self repair (CSR) programs allow you to repair your product. If a CSR part needs to be replaced, it will be shipped directly to you so that you can install it at your convenience. Some parts do not qualify for CSR. Your Hewlett Packard Enterprise authorized service provider will determine whether a repair can be accomplished by CSR.

For more information about CSR, contact your local service provider or go to the CSR website:

<http://www.hpe.com/support/selfrepair>

## Remote support

Remote support is available with supported devices as part of your warranty or contractual support agreement. It provides intelligent event diagnosis, and automatic, secure submission of hardware event notifications to Hewlett Packard Enterprise, which will initiate a fast and accurate resolution based on your product's service level. Hewlett Packard Enterprise strongly recommends that you register your device for remote support.

If your product includes additional remote support details, use search to locate that information.

### Remote support and Proactive Care information

#### HPE Get Connected

[www.hpe.com/services/getconnected](http://www.hpe.com/services/getconnected)

#### HPE Proactive Care services

[www.hpe.com/services/proactivecare](http://www.hpe.com/services/proactivecare)

#### HPE Datacenter Care services

[www.hpe.com/services/datacentercare](http://www.hpe.com/services/datacentercare)

#### HPE Proactive Care service: Supported products list

[www.hpe.com/services/proactivecaresupportedproducts](http://www.hpe.com/services/proactivecaresupportedproducts)

#### HPE Proactive Care advanced service: Supported products list

[www.hpe.com/services/proactivecareadvancedsupportedproducts](http://www.hpe.com/services/proactivecareadvancedsupportedproducts)

#### Proactive Care customer information

##### Proactive Care central

[www.hpe.com/services/proactivecarecentral](http://www.hpe.com/services/proactivecarecentral)

##### Proactive Care service activation

[www.hpe.com/services/proactivecarecentralgetstarted](http://www.hpe.com/services/proactivecarecentralgetstarted)

## Documentation feedback

Hewlett Packard Enterprise is committed to providing documentation that meets your needs. To help us improve the documentation, send any errors, suggestions, or comments to Documentation Feedback ([docsfeedback@hpe.com](mailto:docsfeedback@hpe.com)). When submitting your feedback, include the document title, part number, edition, and publication date located on the front cover of the document. For online help content, include the product name, product version, help edition, and publication date located on the legal notices page.