



by Schneider Electric

Installation Guide Smart-UPS™ RT External Battery Module SRTG192XLBP2

Important Safety Instructions

Read the instructions carefully and look at the equipment to become familiar with the device before trying to install, operate, service or maintain it. The following special messages may appear throughout this document or on the equipment to warn of potential hazards or to call attention to information that clarifies or simplifies a procedure.



The addition of this symbol to either a “Danger” or “Warning” safety label indicates that an electrical hazard exists which will result in personal injury if the instructions are not followed.



This is the safety alert symbol. It is used to alert you to potential personal injury hazards. Obey all safety messages that follow this symbol to avoid possible injury or death.

DANGER

DANGER indicates a hazardous situation which, if not avoided, **will result in** death or serious injury.

WARNING

WARNING indicates a hazardous situation which, if not avoided, **could result in** death or serious injury.

CAUTION

CAUTION indicates a hazardous situation which, if not avoided, **could result in** minor or moderate injury.

NOTICE

NOTICE is used to address practices not related to physical injury.

Product Handling Guidelines



<18 kg
<40 lb



18-32 kg
40-70 lb



32-55 kg
70-120 lb



>55 kg
>120 lb



Safety and General Information

- Adhere to all national and local electrical codes.
- Changes and modifications to this unit not expressly approved by APC by Schneider Electric could void the warranty.
- This unit is intended only for indoor use in a controlled environment.
- Do not operate this unit in direct sunlight, in contact with fluids, or where there is excessive dust or humidity.
- Be sure the air vents on the unit are not blocked. Allow adequate space for proper ventilation.
- Before replacing batteries, remove conductive jewelry such as chains, wrist watches, and rings. High energy through conductive materials could cause severe burns.
- The battery typically lasts for two to five years. Environmental factors impact battery life.
- Elevated ambient temperatures, poor quality mains power, and frequent short duration discharges will shorten battery life.
- The equipment is heavy. Always practice safe lifting techniques adequate for the weight of the equipment.
- The batteries are heavy. Remove the batteries before installing the UPS and external battery modules in a rack.
- Always install XLBPs at the bottom in rack-mount configurations. The UPS must be installed above the XLBPs.
- Do not dispose of battery or batteries in a fire. The batteries may explode.
- Do not open or mutilate batteries. Released electrolyte is harmful to the skin and eyes, and may be toxic.
- Always recycle used batteries.
- Recycle the package materials or save them for reuse.
- Additional safety information can be found in the Safety Guide supplied with this unit.
- A battery can present a risk of electric shock and burns by high short-circuit current.
- Failed batteries can reach temperatures that exceed the burn thresholds for touchable surfaces.
- Battery breaker must be turned off when the UPS is not operating for a long time.
- Servicing of user replaceable batteries should to be performed or supervised by personnel knowledgeable about batteries and required precautions.

Battery safety

CAUTION

RISK OF FALLING OBJECTS

- Each battery module weighs 24.5 kg (54 lb).
- Always practice safe lifting techniques adequate for the weight of the equipment.
- Remove the battery modules before installing the SRTG192XLBP2.
- Use the battery module handle to carefully slide the battery modules in or out of the SRTG192XLBP2.
- Do not use the battery module handle to lift or carry the battery module.

Failure to follow these instructions can result in equipment damage and minor or moderate injury.

CAUTION

RISK OF HYDROGEN SULPHIDE GAS AND EXCESSIVE SMOKE

- Replace the battery at least every 5 years or at the end of its service life, whichever is earlier.
- Replace the battery immediately when the UPS indicates battery replacement is necessary.
- Replace batteries with the same number and type of batteries as originally installed in the equipment.
- Replace the battery immediately when the UPS indicates a battery over-temperature condition, or UPS internal over-temperature, or when there is evidence of electrolyte leakage. Power off the UPS, unplug it from the AC input, and disconnect the batteries. Do not operate the UPS until the batteries have been replaced.
- *Replace all battery modules (including the modules in External Battery Packs) which are older than one year, when installing additional battery packs or replacing the battery module(s).





Failure to follow these instructions can result in minor or moderate injury and equipment damage.

* Contact APC by Schneider Electric Worldwide Customer Support to determine the age of the installed battery modules.

Package Contents

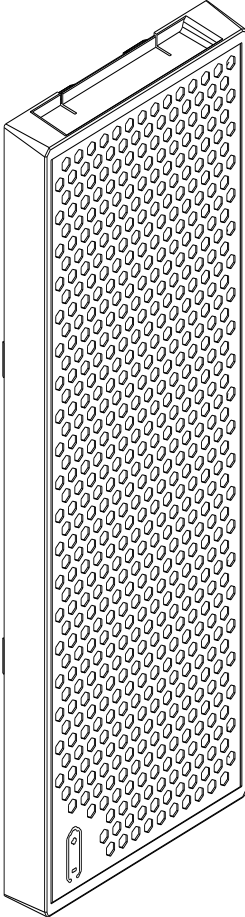
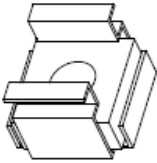
Inspect the contents upon receipt. Notify the carrier and dealer if there is damage.

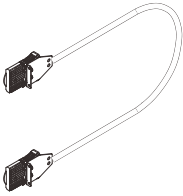
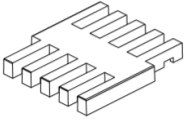
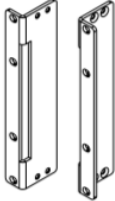
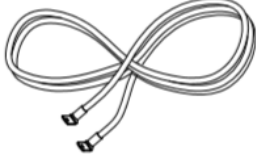
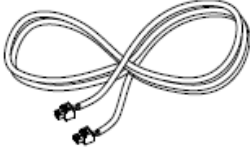
Included with all models:

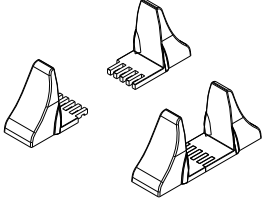
<p>Front bezel</p>  <p>(x1)</p>	<p>M5 Floating nut to secure the battery pack to the rack</p>  <p>(x4)</p> <p>M4x8 flat head screws to secure the rack-mount brackets to the UPS</p>  <p>(x8)</p> <p>M5x12 Phillips flat head screw to secure the XLBP to the rack</p>  <p>(x4)</p> <p>Battery cable 0.64m</p>  <p>(x1)</p>	<p>Stabilizer bracket connectors</p>  <p>(x8)</p> <p>Rack-mount brackets</p>  <p>(x1 pair)</p> <p>Ground wire 0.64m</p>  <p>(x1)</p> <p>Battery pack temperature sensor wire 0.64m</p>  <p>(x1)</p>	<p>Installation manual</p>  <p>(x1)</p> <p>Packing list</p>  <p>(x1)</p> <p>Stabilizer bracket</p>  <p>(x2 pairs)</p>
---	---	---	---

Specifications

For additional specifications, refer to the APC by Schneider Electric Web site at www.apc.com.

Environmental

Temperature	Operating	0 to 40 °C (32 to 104 °F)
	Storage	-15 to 45 °C (5 to 113 °F)
Maximum Elevation	Operating	0 - 3,000 m (0 - 10,000 ft) 0-1,000 m no derating; 1,000 to 3,000 m, power reduction of 1%/100 m
	Storage	0 - 15,000 m (50,000 ft.)
Humidity		0% to 95% relative humidity, non-condensing
International Protection Code		IP20
<p>Note: Charge the battery modules every six months during storage. Environmental factors impact battery life. Elevated ambient temperatures, high humidity, poor quality mains power, and frequent short duration discharges will shorten battery life.</p>		

Physical

The XLBP is heavy. Follow all lifting guidelines.

XLBP model	SRTG192XLBP2
Unit weight batteries included, without packaging	116 kg
Unit weight batteries included, with packaging	133 kg
Unit dimensions without packaging Height x Width x Depth	175 x 440 x 700 mm (6.89 x 17.32 x 27.56 in.)
Unit dimensions with packaging Height x Width x Depth	445 x 600 x 800 mm (17.52 x 23.62 x 31.50 in.)
The model and serial numbers are on a small label located on the rear panel.	

Battery

UPS model	SRTG15KXLI/SRTG20KXLI
XLBP model	SRTG192XLBP2
Replacement battery module This UPS has replaceable battery modules. Refer to the appropriate replacement battery user manual for installation instructions. Contact your dealer or go the APC by Schneider Electric Web site, www.apc.com for information on replacement batteries.	APCRBC172
Total Voltage of battery pack for UPS Ah rating	±192 VDC 9 Ah
Battery type	Sealed Maintenance Free Valve Regulated Lead Acid
Number of battery pack	4 battery packs excluding the one supplied with UPS
XLBP cable length	0.64 m

Remove Battery Modules

⚠ CAUTION

RISK OF FALLING OBJECTS

- The equipment is heavy. Each battery module weighs 24.5 kg (54 lb).
- Always practice safe lifting techniques adequate for the weight of the equipment.
- Remove the battery modules before installing the XLBP.
- Use the battery module handle to slide the battery modules in or out of the XLBP.
- Do not use the battery module handle to lift or carry the battery module.

Failure to follow these instructions can result in equipment damage and minor or moderate injury.

- 1 Remove the screws securing the battery compartment door and remove the battery compartment door.

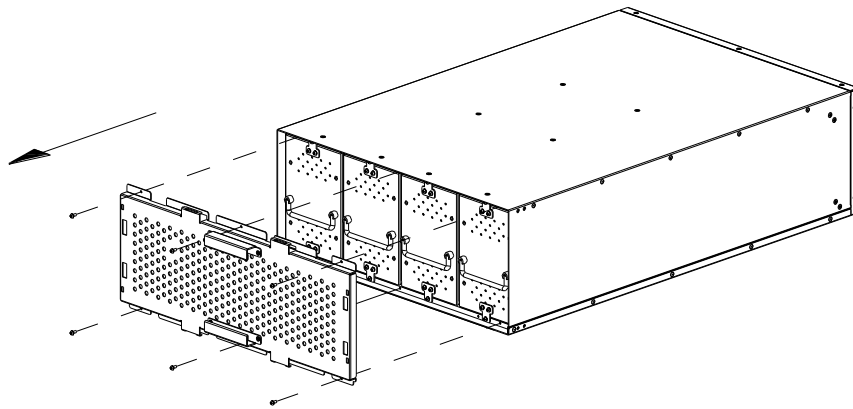

- 2 Remove the screws securing the battery modules.

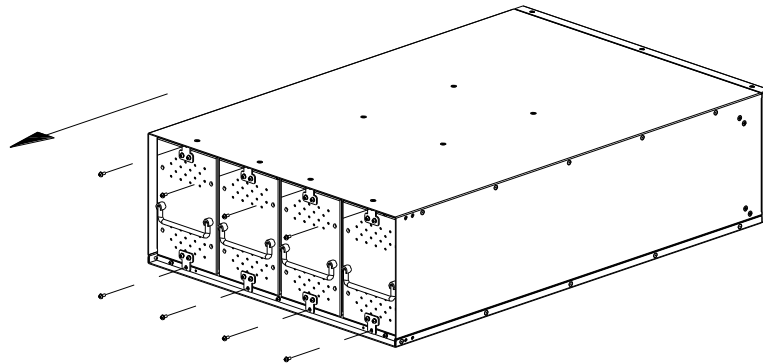

- 3 Remove the battery modules from the battery pack.

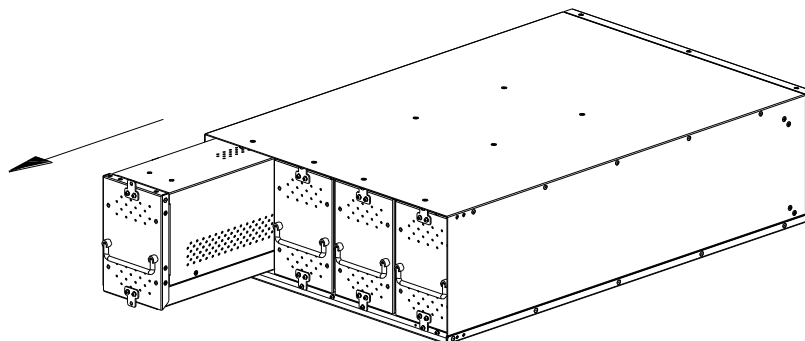

Rack-Mount Installation

Your UPS model may differ in appearance from those depicted in these graphics. The SRTG192XLBP2 installation process is identical for all models.

Refer to the rail kit Installation Guide for instructions on rail installation.

⚠ CAUTION

RISK OF FALLING OBJECTS

- The equipment is heavy. Always practice safe lifting techniques adequate for the weight of the equipment.
- Always use the recommended number of screws to secure rack-mount brackets to the XLBP.
- Always use the recommended number of screws and cage nuts to secure XLBP to the rack.
- Always install the XLBP at the bottom of the rack.
- Always install the XLBP below the UPS in the rack.
- Use the battery module handle to slide the battery modules in or out of the XLBP.
- Do not use the battery module handle to lift or carry the battery module.

Failure to follow these instructions can result in equipment damage and minor or moderate injury.

- 1 Secure the front of rail (SRTGRK2) with 10 (M5x12) screws.

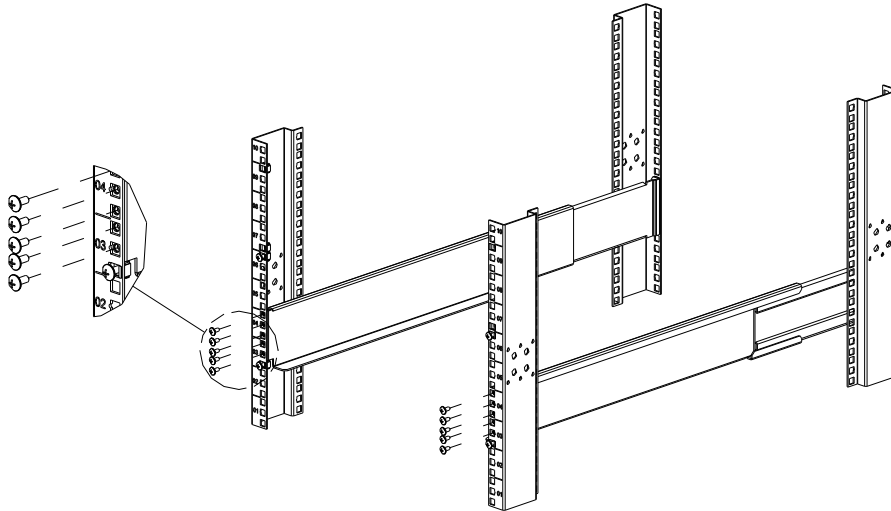

- 2 Secure the back of rail (SRTGRK2) with 8 (M5x12) screws.

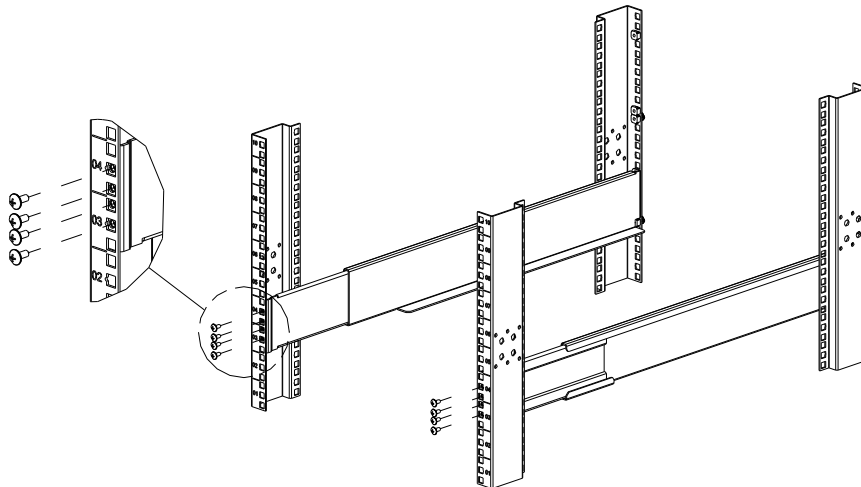

- 3 Secure the rack-mount brackets to the battery pack with 8 (M4x8) screws.

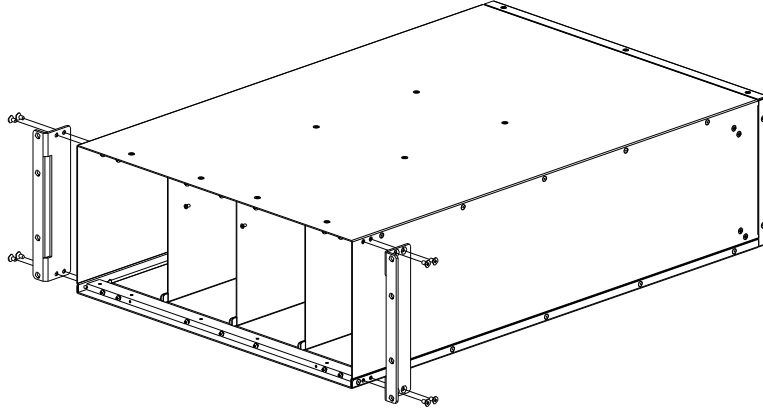

- 4 Rest the XLBP on the rail (SRTGRK2) shelves. Slide the XLBP into the rack.

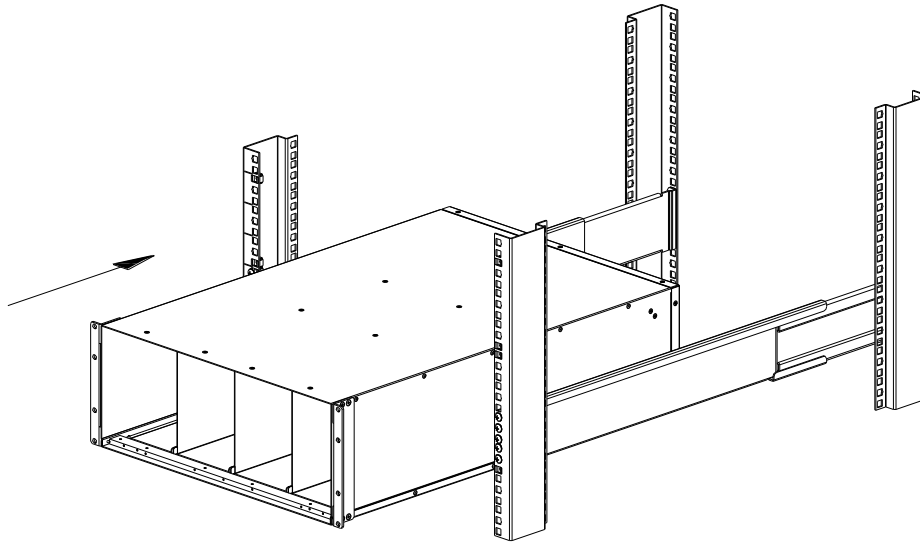

- 5 Secure rack-mount brackets to the rack with 4 (M5x12) screws.

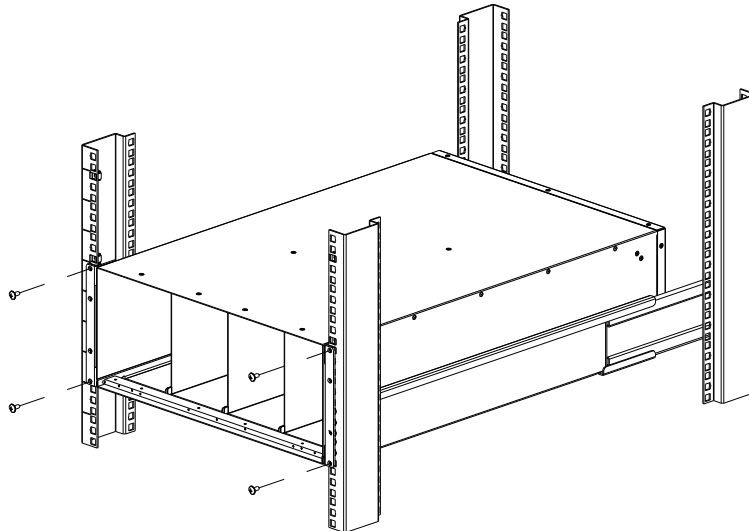

- 6 Install four battery modules.

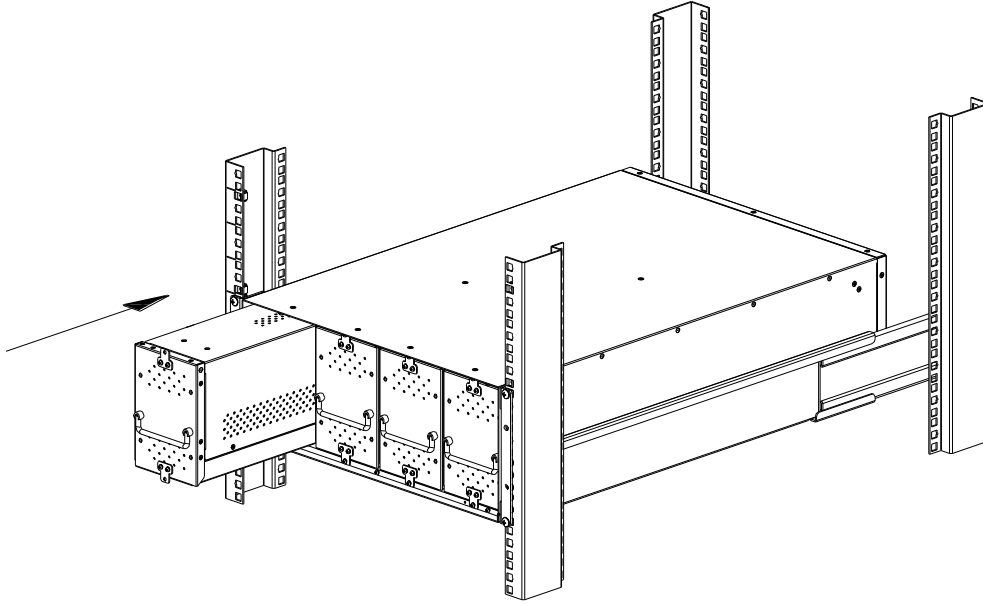

- 7 Secure the battery modules with 8 (M3x8) screws.

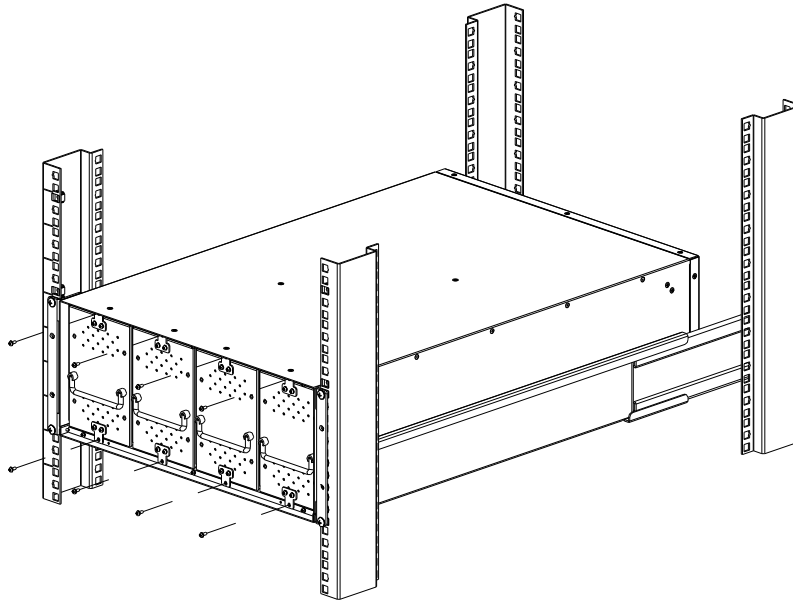

- 8 Secure the battery compartment door to the battery pack with 6 (M3x8) screws.

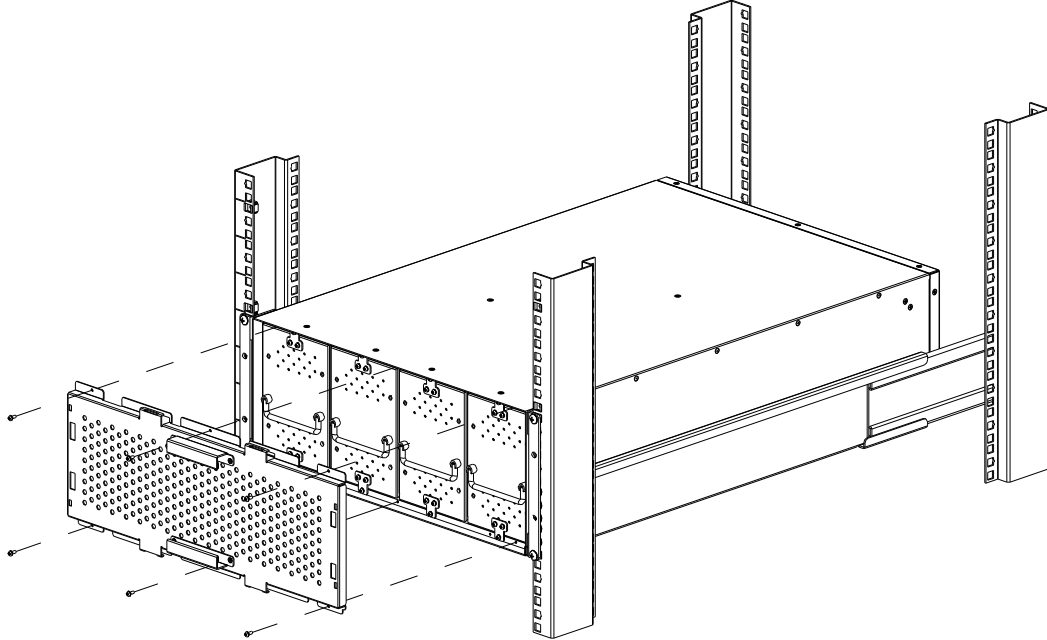

- 9 Install the front bezel of XLBP.

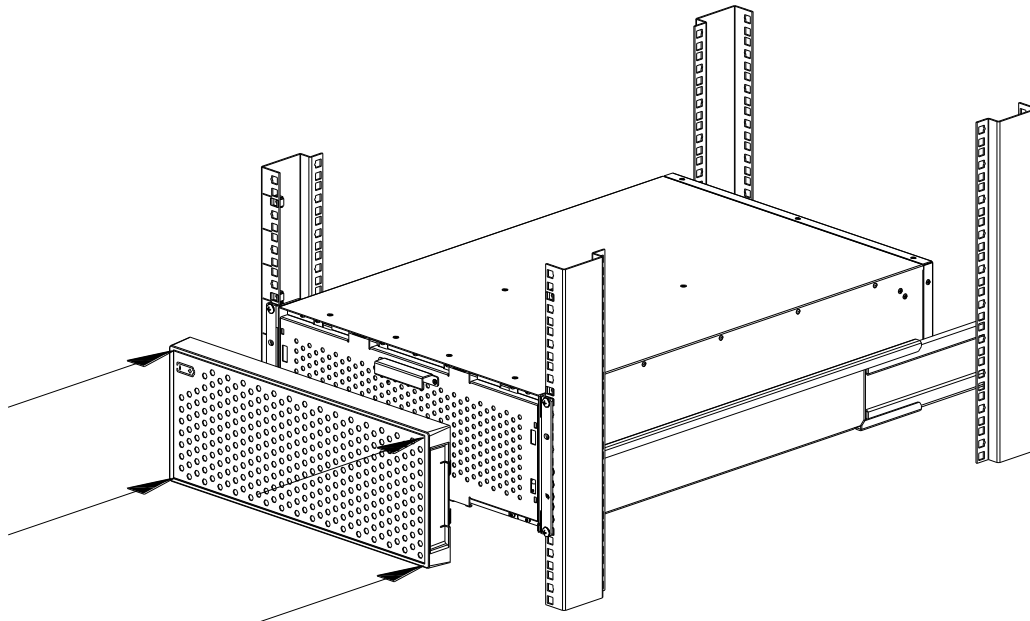

Tower Installation

⚠ CAUTION

RISK OF FALLING OBJECTS

- Prior to installing the tie brackets, select a location sturdy enough for the combined weight of the units.
- Do not move the units once the tie brackets are installed.
- Always install stabilizer brackets when an XLBP and UPS model SRTG15K/20KXLI are installed together in tower configuration.
- Always install stabilizer brackets when an XLBP is installed in tower configuration and not secured to a UPS.

Failure to follow these instructions can result in equipment damage and minor or moderate injury.

- 1 Remove the battery modules. Refer "Remove Battery Modules" on page 6 for details.
- 2 Assemble battery pack stabilizer bracket.

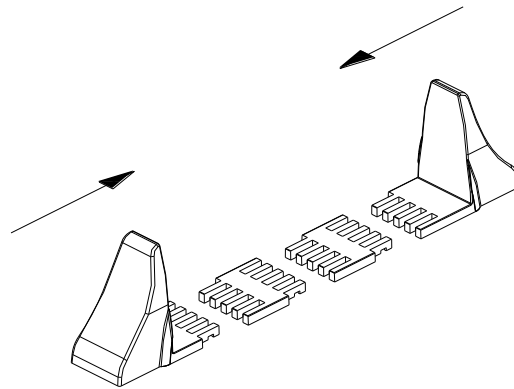

- 3 Change the orientation of the battery pack to tower orientation.

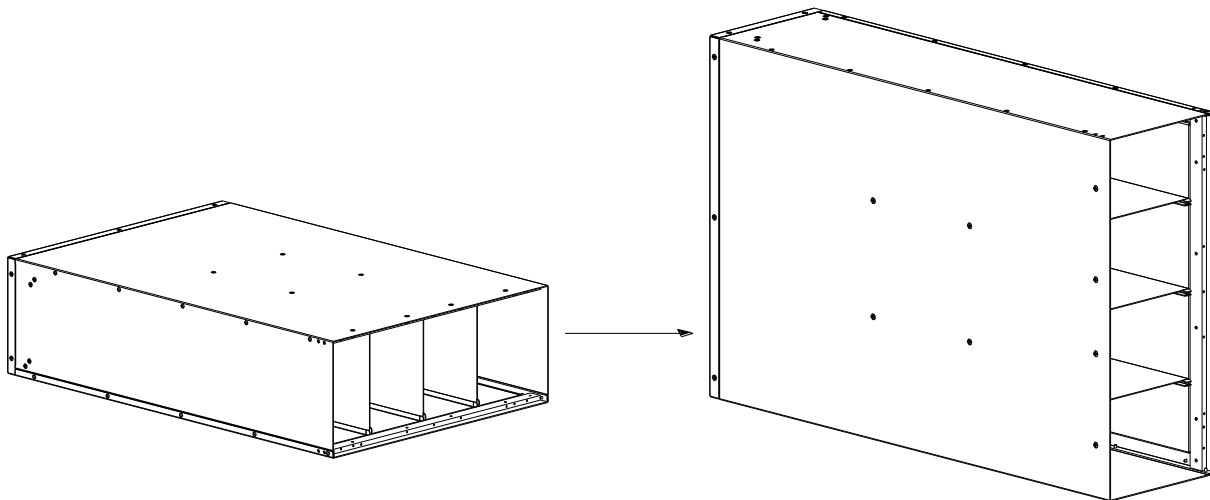

- 4 Install four battery modules.

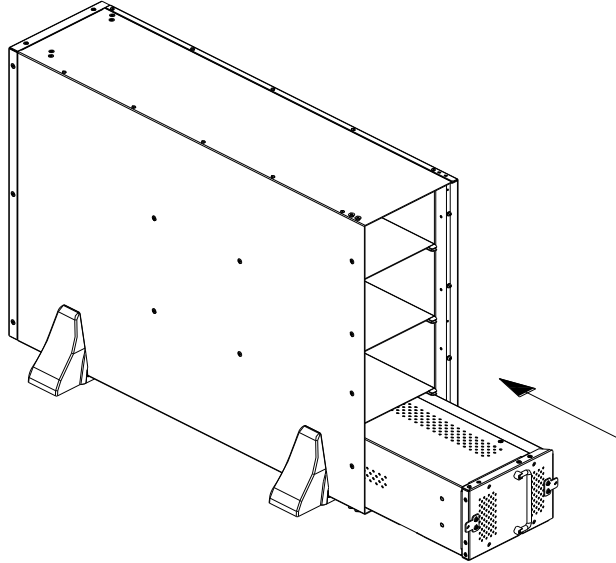

- 5 Secure the battery modules with 8 (M3x8) screws.

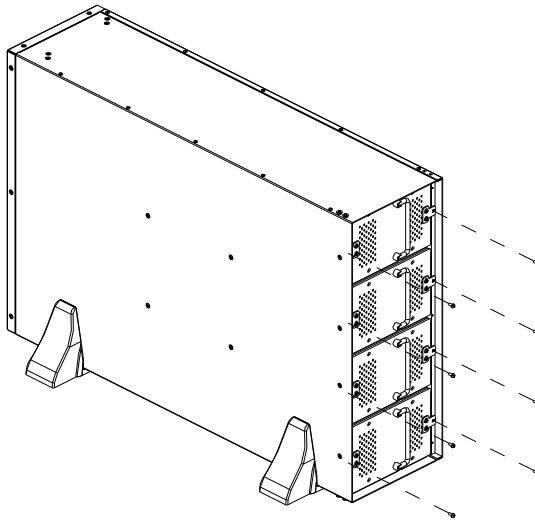

- 6 Secure the battery compartment door to the battery pack with 6 (M3x8) screws.

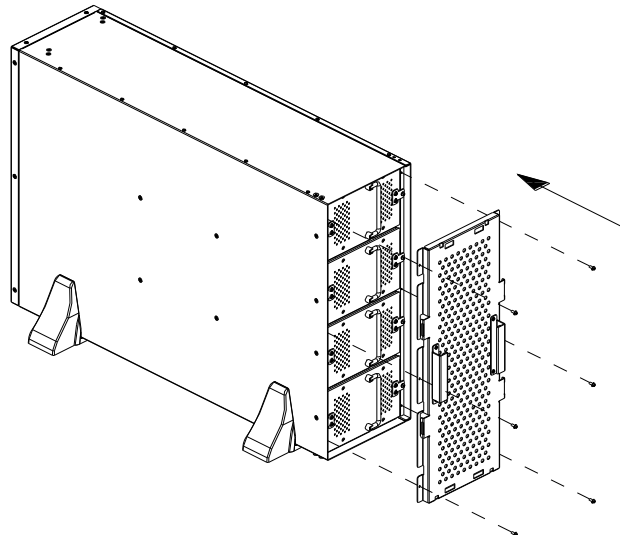

- 7 Install the front bezel of XLBP.

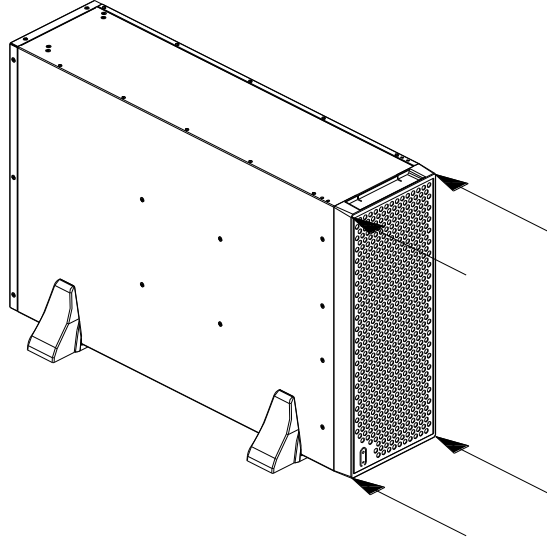

UPS models SRTG15K/SRTG20K XLI with XLBP

- 1 Assemble battery pack stabilizer bracket.

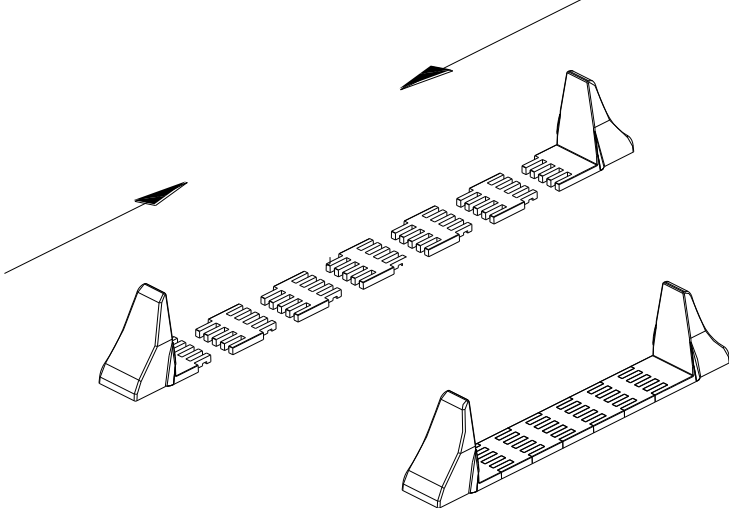

- 2 Install the UPS module and battery pack on the stabilizer brackets.

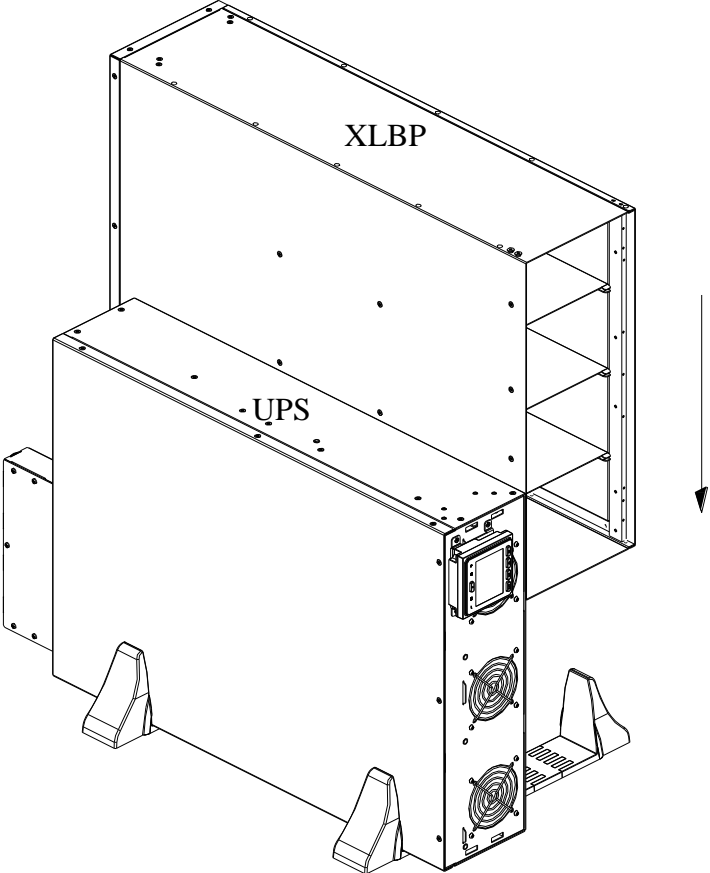

- 3 Install four battery modules.

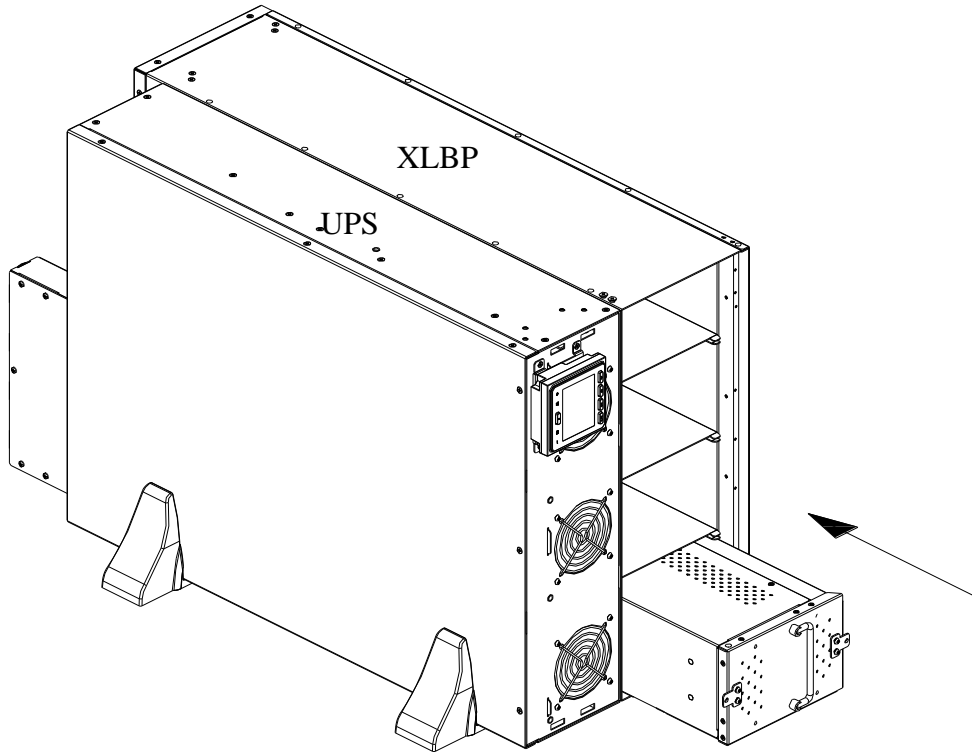

- 4 Secure the battery modules with 8 (M3x8) screws.

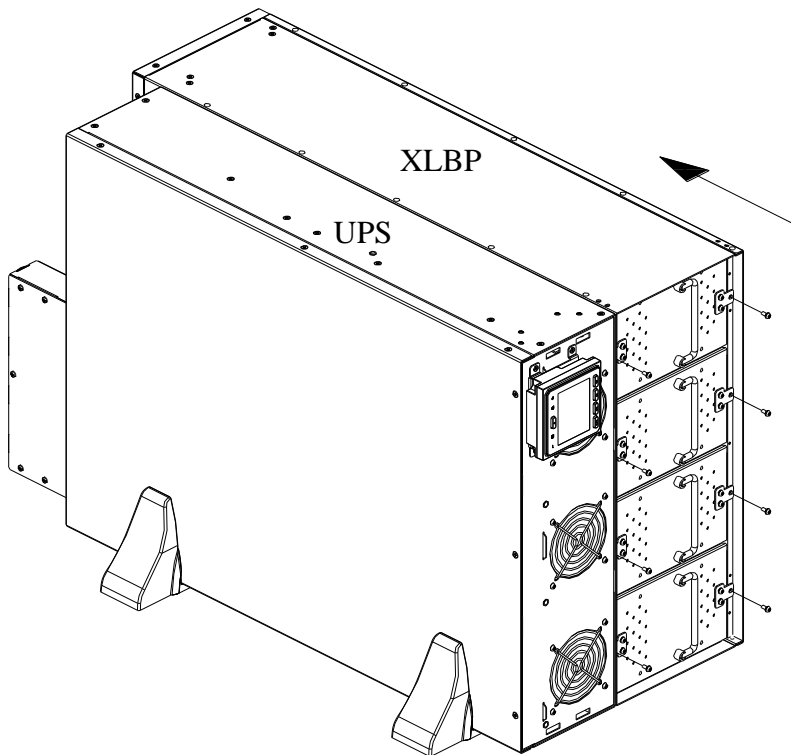

- 5 Secure the battery compartment door to the battery pack with 6 (M3x8) screws.

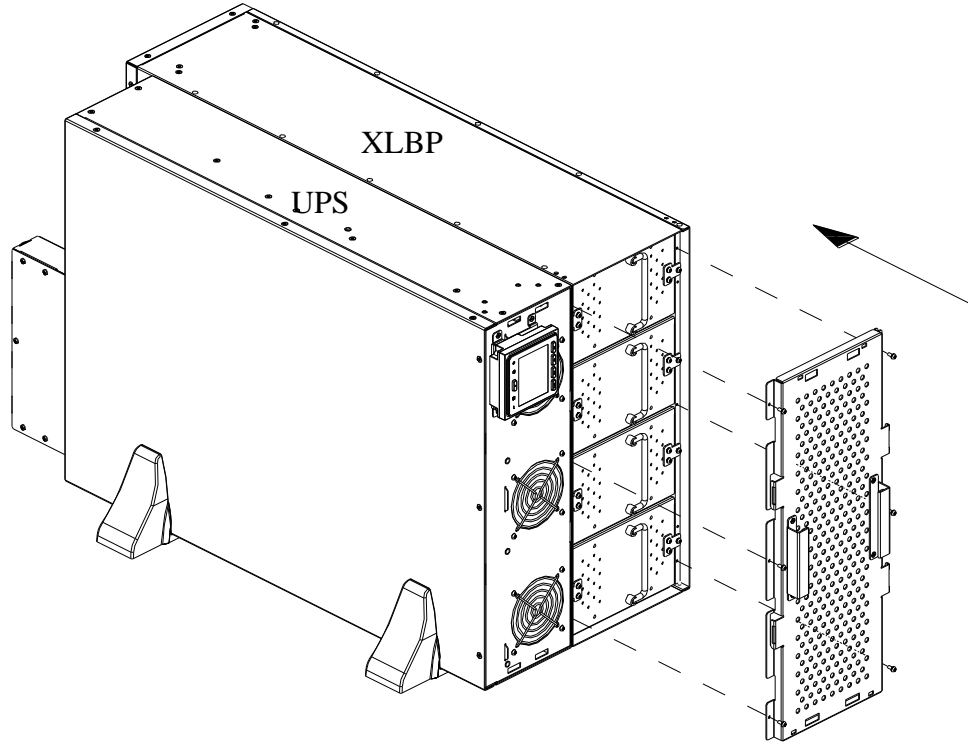

- 6 Rotate the LCD of UPS module 90 degrees to the right.

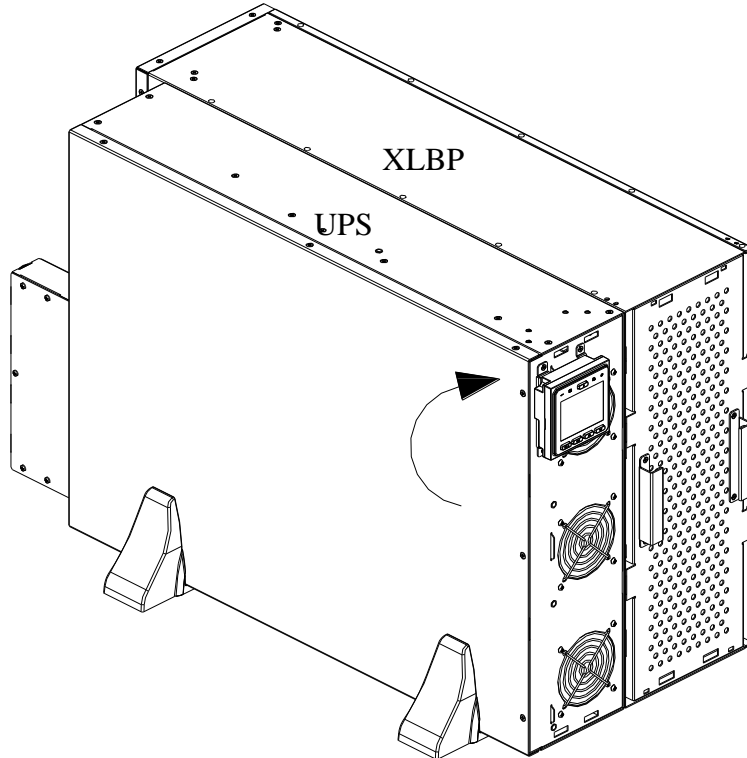

- 7 Install the front bezels of both the UPS and the battery pack.

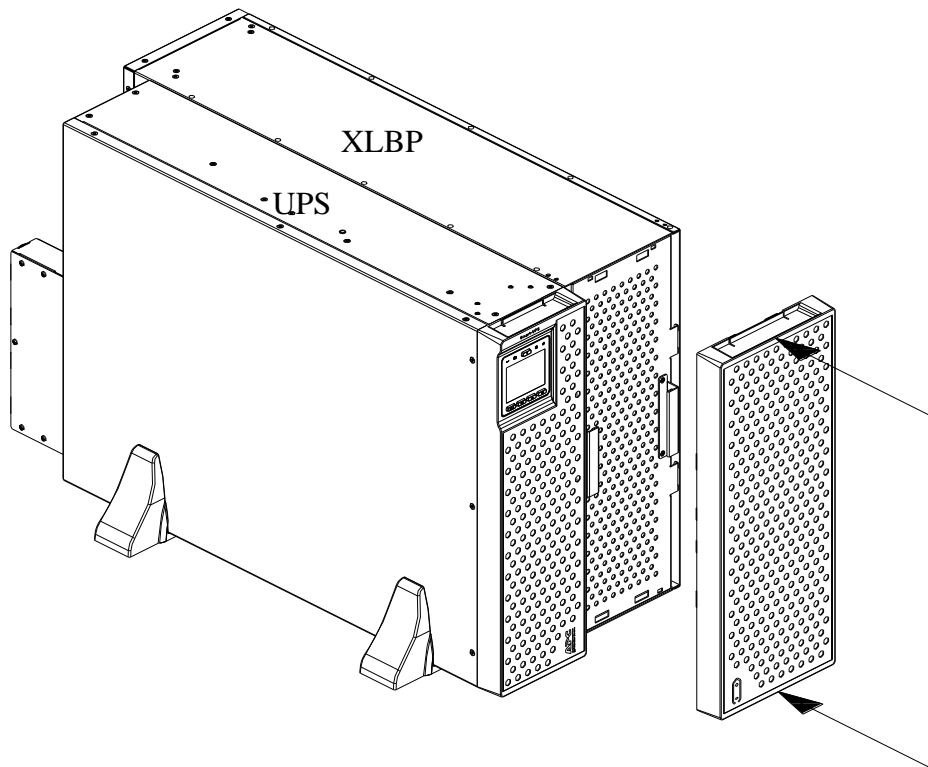

Rear Panel Features

Note: Refer to the table “Key to identify rear panel features” on page 18, that provides a key to the call out numbers for the rear panel graphics depicted in this manual.
This picture is for reference only. The physical object may be different.

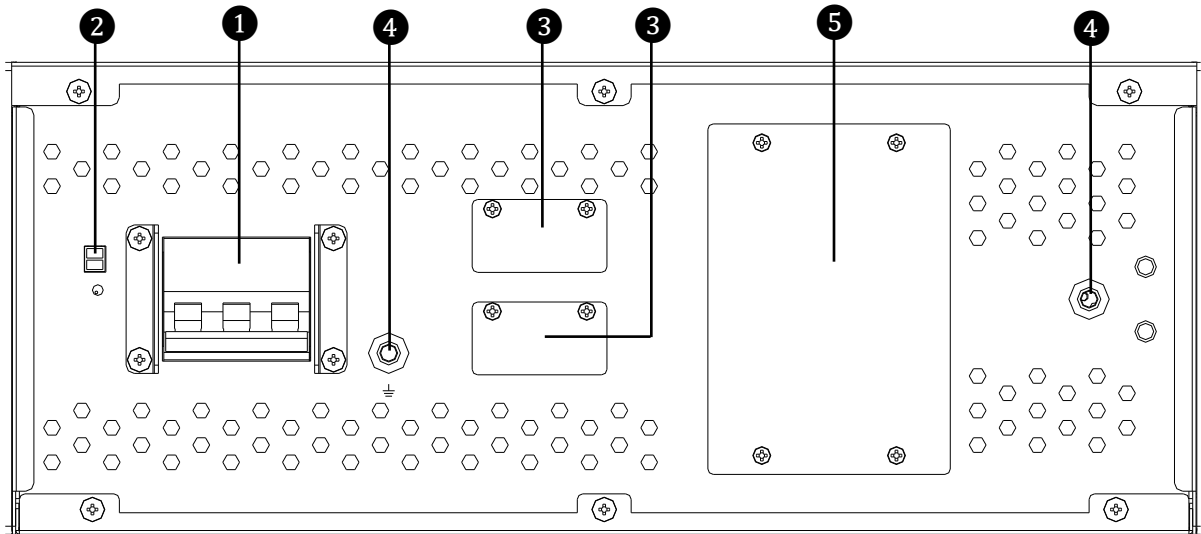

Key to identify rear panel features

①	Battery breaker	Connects or disconnects batteries.
②	BAT_T	Battery temperature sensor.
③	Battery connector	Enables connection of battery pack to UPS or connection of additional battery packs.
④	Ground screw	Connect to ground.
⑤	Battery Fuse	2 pieces of 100 A / 500 Vdc fuse.

Connect Ground and Battery Wires

SRTG15K/20K XLI models with two SRTG192XLBP2

Connect ground wires

Recommended screw torque, 2.72 Nm (24 lbf-in)

Recommended method 1:

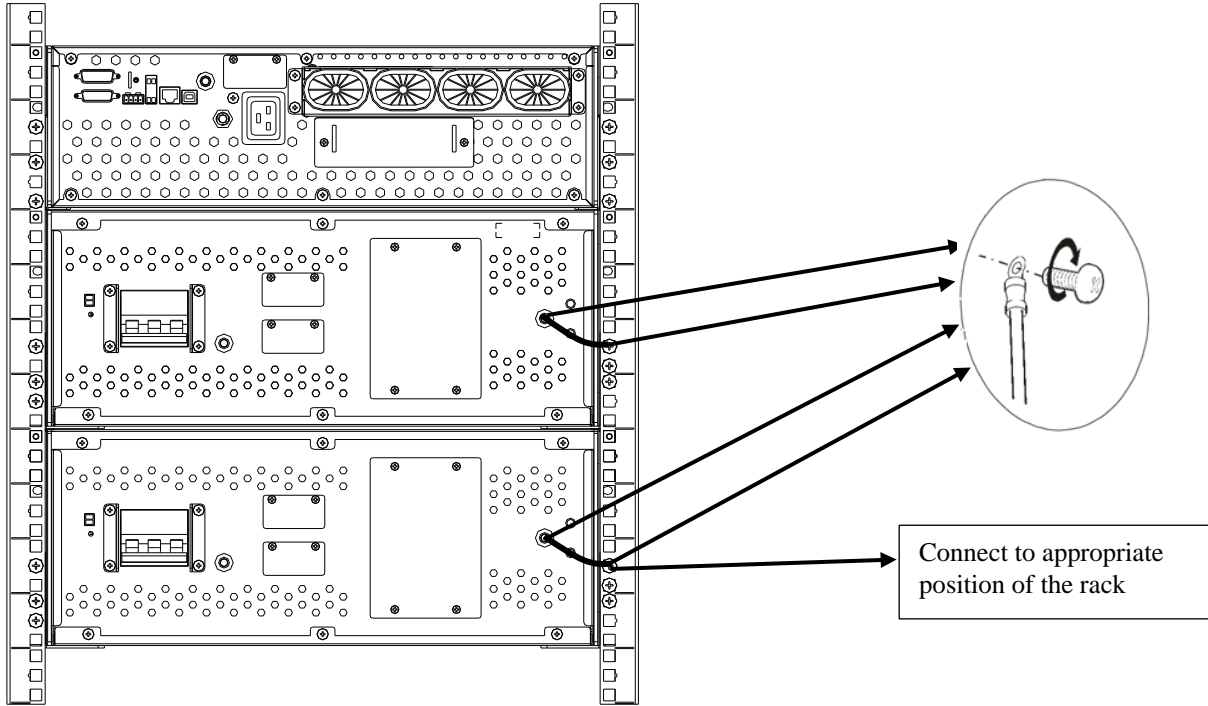

Recommended method 2:

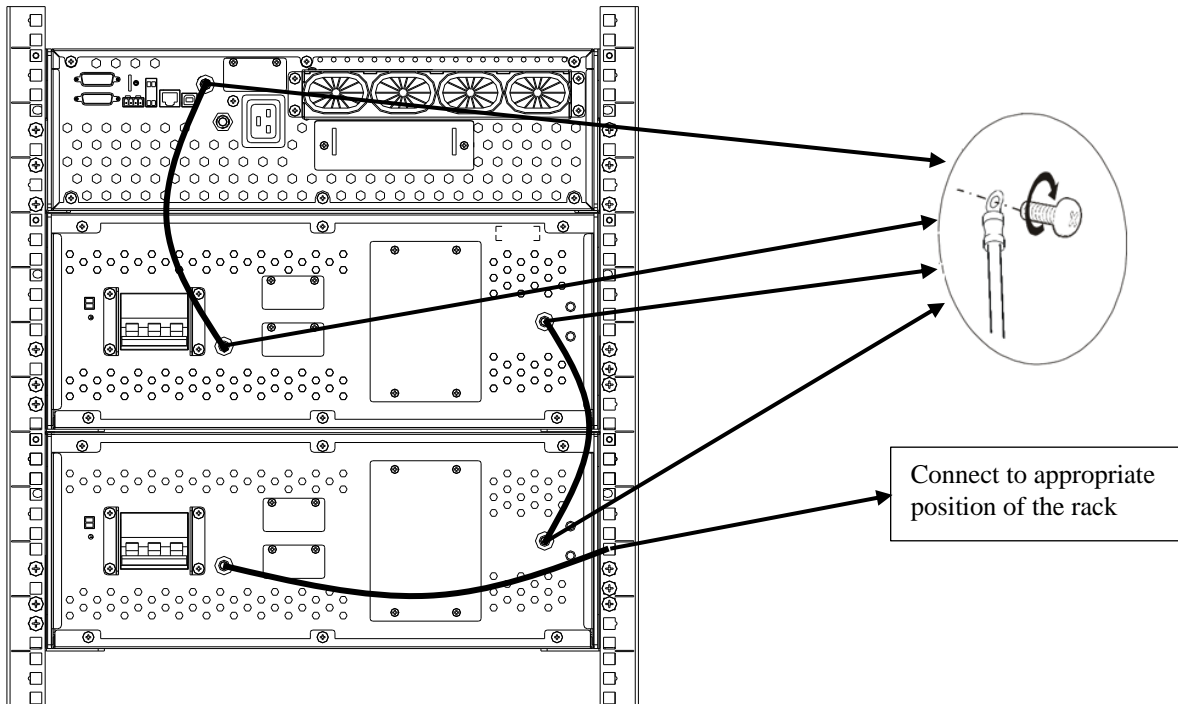

Connect external battery pack wires

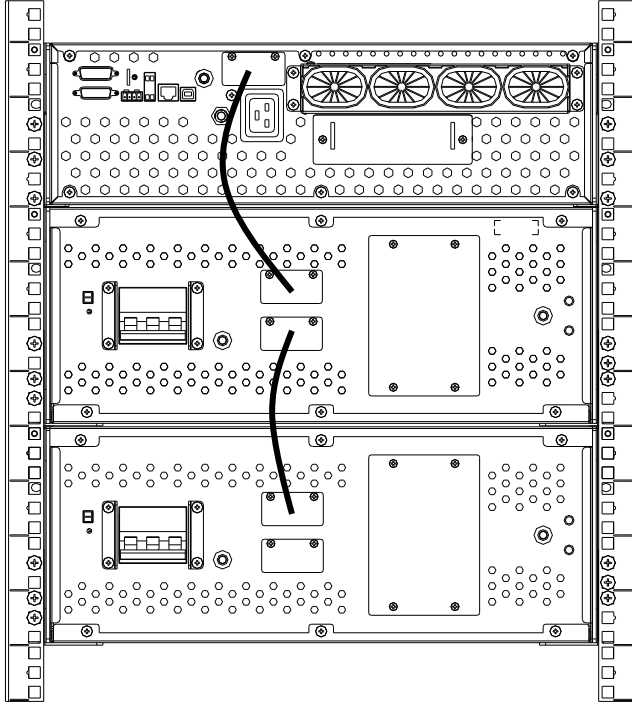

Recycling Used Battery

For disposing/recycling used batteries, visit APC by Schneider Electric Website
www.apc.com → Choose your country → Support → Recycling options.

APC by Schneider Electric Worldwide Customer Support

Customer support for this or any other APC™ by Schneider Electric product is available at no charge in any of the following ways:

- Visit the APC by Schneider Electric Web site to access documents in the APC by Schneider Electric Knowledge Base and to submit customer support requests.
 - www.apc.com (Corporate Headquarters)
Connect to localized APC by Schneider Electric Web sites for specific countries, each of which provides customer support information.
 - www.apc.com/support/
Global support searching APC by Schneider Electric Knowledge Base and using e-support.
- Contact APC by Schneider Electric Customer Support Center by telephone or e-mail.
 - Local, country specific centers: go to www.apc.com/support/contact for contact information.

For information on how to obtain local customer support, contact the APC by Schneider Electric representative or other distributor from whom you purchased your APC by Schneider Electric product.

User Document Link

Refer the link or scan the QR code to access the user documentation:

SRTG192XLBP2

<https://d.go2se.com/SRTG192XLBP2>



Customer support and warranty information are available on the APC by Schneider Electric Web site, www.apc.com.

© 2020 APC by Schneider Electric. APC, the APC logo, and Smart-UPS are owned by Schneider Electric Industries S.A.S., or their affiliated companies. All other trademarks are property of their respective owners.

EN 990-6210
08/2020