







ANTENNAS | EPNT-1 SERIES

## X-POLARISED, OMNI-DIRECTIONAL, 5G/LTE & WI-FI CPE

617 – 3800 MHz; 4x4 LTE/5G (MIMO), 5 dBi; 2x2 Wi-Fi (MIMO), 7 dBi;



 617 – 960 MHz 1427 – 1517 MHz 1710 – 2700 MHz 3400 – 3800 MHz	 5 dBi	 Increase X Mb/s	 Omni- Directional	 5G	 4G LTE
 CBRS Band	 4x4 MIMO	 2.4 – 2.5 GHz 5.0 – 7.2 GHz	 Fire Resistant	 IP 65	 -40°C to +80°C



APPLICATION AREAS

- Antenna enclosure with high performance antennas
- Wideband 4x4 MIMO 4G/5G antenna
- 2x2 MIMO dual-band 2.4 GHz and 5 – 7.2 GHz Wi-Fi antennas
- Cross polarised antennas for improved performance
- IP65 weather/dust and vandal resistant enclosure

### Product Overview

Poynting Antennas introduces its all-new antenna enclosure range, the ePoynt series. The ePoynt enclosures are designed to fit a variety of router modules, transforming the antenna enclosure into a Customer Premises Equipment (CPE) – just add your own LTE/5G router. The ePoynt enclosure can accommodate routers up to the size of 185 x 145 x 45 mm<sup>3</sup>. The ePoynt-1 (EPNT-1) combines our cross-polarised omni-directional antennas for enhanced performance. This is ideal in built-up areas where there are several base stations close by, but where higher stability and throughput is required due to its enhanced MIMO configuration.

The EPNT-1 includes four cross-polarised antennas, making it ideal for 4x4 MIMO or dual 2x2 MIMO routers. The antennas offer wideband coverage from 617 to 3800 MHz, making it ideal for LTE & 5G implementation with a peak gain of 5 dBi. The EPNT-1 also includes two omni-directional dual-band Wi-Fi antennas that cover the 2.4 GHz and 5 to 7.2 GHz Wi-Fi bands for 2x2 MIMO. The EPNT-1 enclosure was also designed to withstand adverse weather conditions, making the antenna weatherproof and waterproof with an IP65 rating.

### Features

- Ultra-wideband coverage for 2G, 3G, 4G and 5G
- Omni-directional antennas with peak gain of 5 dBi
- 4x4 MIMO for improved performance
- Wall, pole and window mountable
- Weatherproof and waterproof enclosure (IP65)
- 1x Ethernet port

### Application Areas

- Outdoor antenna for Fixed Wireless Access (FWA)
- Consumer 5G/LTE internet connectivity
- Industrial and commercial 5G/LTE deployment
- Urban and rural household reception enhancement
- Oil & Gas communication systems



**Frequency Bands**

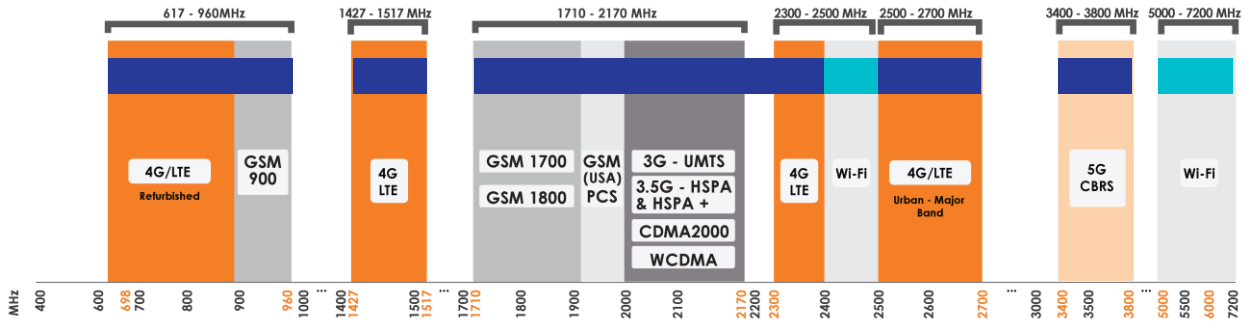

The EPNT-1 is an Omni-directional antenna that works from | 617 – 960 MHz | 1427 – 1517 MHz | 1710 – 2700 MHz | 3400 – 3800 MHz | and the following Wi-Fi frequency bands | 2400 – 2500 MHz | and | 5000 – 7200 MHz |



Indicates the LTE bands on which EPNT-1 works

Indicates the WI-FI bands on which EPNT-1 works

**Antenna Overview**

		
<b>Ports</b>	Cell 1 & Cell 2 Main Cell 1 & Cell 2 Aux/Div	1 & 2
<b>SISO / MIMO</b>	4x4 MIMO	2x2 MIMO
<b>Frequency Bands</b>	617 - 3800 MHz	2400 - 2500 MHz 5000 - 7200 MHz
<b>Peak Gain</b>	5 dBi	7 dBi
<b>Connector Type*</b>	SMA (F)	SMA (F)

*\* The connectors are factory mounted to the antenna  
Additional pigtailed (not supplied) are required to connect the antenna to the router  
See accessories section at the end of this document for pigtail options offered*

## Electrical Specifications - Cellular

<b>Frequency Bands:</b>	617 – 960 MHz 1427 – 1517 MHz 1710 – 2700 MHz 3400 – 3800 MHz
<b>Gain (max):</b>	1 dBi @ 617 – 960 MHz 2.5 dBi @ 1427 – 1517 MHz 5 dBi @ 1710 – 2700 MHz 4.5 dBi @ 3400 - 3800 MHz
<b>VSWR:</b>	≤2.5:1
<b>Feed Power Handling:</b>	10 W
<b>Input Impedance:</b>	50 Ohm (nominal)
<b>Polarisation:</b>	Cell 1: ±45° Cell 2: Vertical & Horizontal linear
<b>Path to Ground:</b>	Yes

## Wi-Fi Electrical Specifications

<b>Frequency:</b>	2400 - 2500 MHz 5000 – 7200 MHz
<b>Gain (Max):</b>	3 dBi @ 2400 - 2500 MHz 7 dBi @ 5000 - 7200 MHz
<b>VSWR:</b>	<2.5:1 over 90% of the band
<b>Feed Power Handling:</b>	10 W
<b>Nominal Input Impedance:</b>	50 Ohm (nominal)
<b>Polarisation:</b>	Vertical & Horizontal Linear
<b>Path to Ground:</b>	Yes

## Product Box Contents

<b>Antenna:</b>	A-EPNT-0001-V1-01
-----------------	-------------------

## Ordering Information

<b>Commercial Name:</b>	EPNT-1
<b>Order Product Code:</b>	A-EPNT-0001-V1-01
<b>EAN Number:</b>	6009710922521

## Mechanical Specifications

<b>Product Dimensions:</b>	260 mm x 264 mm x 168 mm
<b>Maximum Router Dimensions:</b>	185 mm x 145 mm x 45 mm
<b>Packaged Dimensions:</b>	450 mm x 270 mm x 180 mm
<b>Weight:</b>	1.035 kg
<b>Packaged Weight:</b>	1.785 kg
<b>Radome Material:</b>	UV Stable ASA
<b>Radome Colour:</b>	Brilliant White Pantone P 179-1C
<b>Mounting Type:</b>	Wall/ Pole and Window Mounted

## Environmental Specifications, Certification & Approvals

<b>Wind Survival:</b>	≤220 km/h
<b>Temperature Range (Operating):</b>	-40°C to +70°C
<b>Environmental Conditions:</b>	Outdoor/Indoor
<b>Water Ingress Protection Ratio/Standard:</b>	IP65
<b>Salt Spray:</b>	MIL-STD 810G/ASTM B117
<b>Operating Relative Humidity:</b>	Up to 98%
<b>Storage Humidity:</b>	5% to 95% - non-condensing
<b>Storage Temperature:</b>	-40°C to +70°C
<b>Enclosure Flammability Rating:</b>	UL 94-HB
<b>Impact Resistance:</b>	IK 08
<b>Product Safety &amp; Environmental:</b>	Complies with CE and RoHS standards

*\*Routers/Router boards have their own operating temperatures as provided in their individual data sheets. Routers/router boards mounted within an EPNT-1 which is exposed to solar radiation will operate at 10-12°C above ambient temperature. Please take this into consideration and select your device to be used with the EPNT-1 accordingly.*

**Antenna Performance Plots - Cellular**

**VSWR: Cellular Antenna**

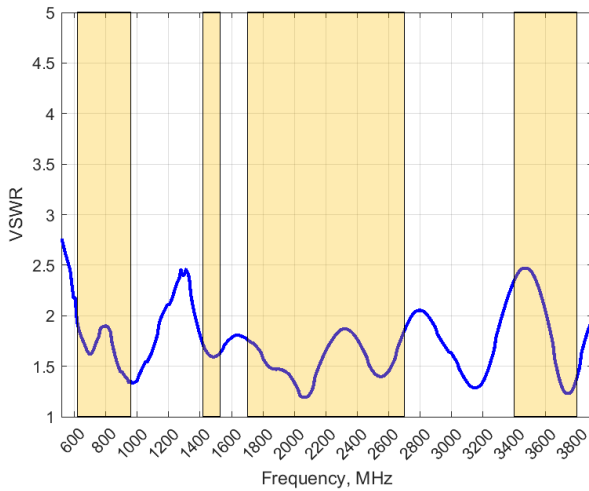

**Voltage Standing Wave Ratio (VSWR)\***

VSWR is a measure of how efficiently radio-frequency power is transmitted from a power source, through a transmission line, into a load. In an ideal system, 100% of the energy is transmitted which corresponds to a VSWR of 1:1.

The EPNT-1 delivers superior performance across all bands with a VSWR of 2.5:1 or better across all bands.

*\*VSWR measured without a cable.*

**GAIN (EXCLUDING CABLE LOSS): Cellular Antenna**

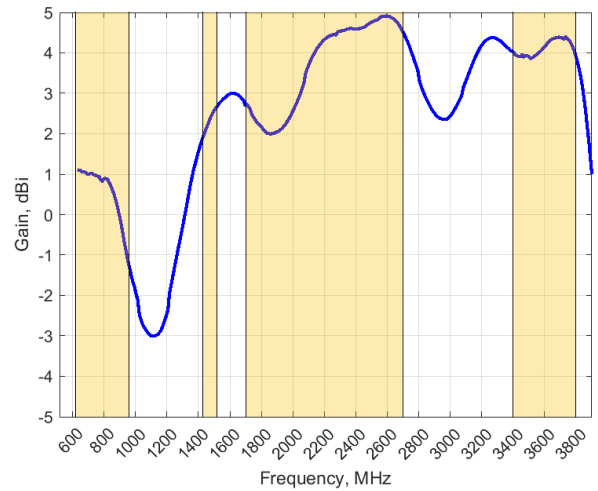

**Gain\* in dBi**

5 dBi is the peak gain across all bands from 617 – 3800 MHz

Gain @ 617 – 960 MHz:	1 dBi
Gain @ 1427 – 1517 MHz:	2.5 dBi
Gain @ 1710 – 2700 MHz:	5 dBi
Gain @ 3400 – 3800 MHz:	4.5 dBi

*\*Antenna gain measured with polarisation aligned standard antenna*

**VSWR: Wi-Fi Antenna**

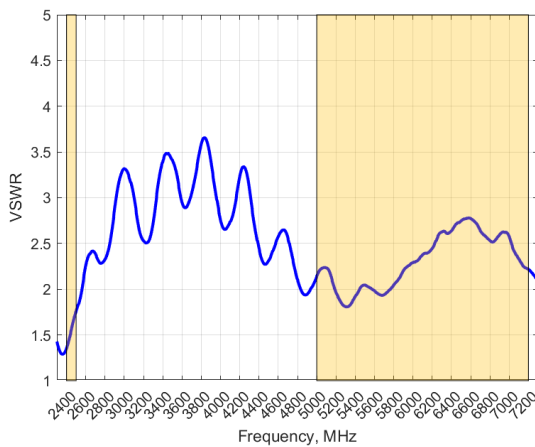

**Voltage Standing Wave Ratio (VSWR)\***

VSWR is a measure of how efficiently radio-frequency power is transmitted from a power source, through a transmission line, into a load. In an ideal system, 100% of the energy is transmitted which corresponds to a VSWR of 1:1.

The EPNT-1 delivers superior performance across all bands with a VSWR of <3:1.

*\*VSWR measured without a cable.*

**GAIN (EXCLUDING CABLE LOSS): Wi-Fi Antenna**

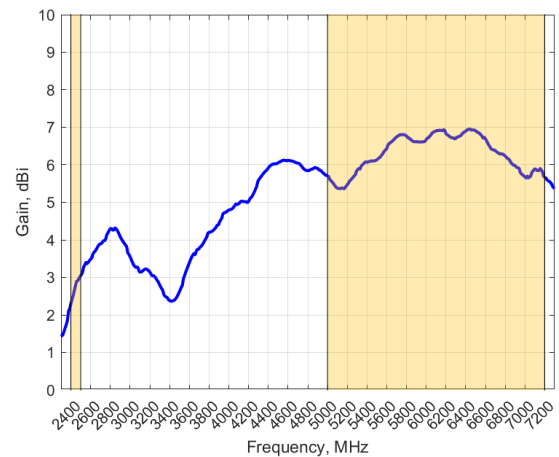

**Gain\* in dBi**

7 dBi is the peak gain across all bands from 2400 – 2500 MHz and 5000 – 7200 MHz

Gain @ 2400 - 2500 MHz:	3 dBi
Gain @ 5000 – 7200 MHz:	7 dBi

*\*Antenna gain measured with polarisation aligned standard antenna*

Technical Drawings

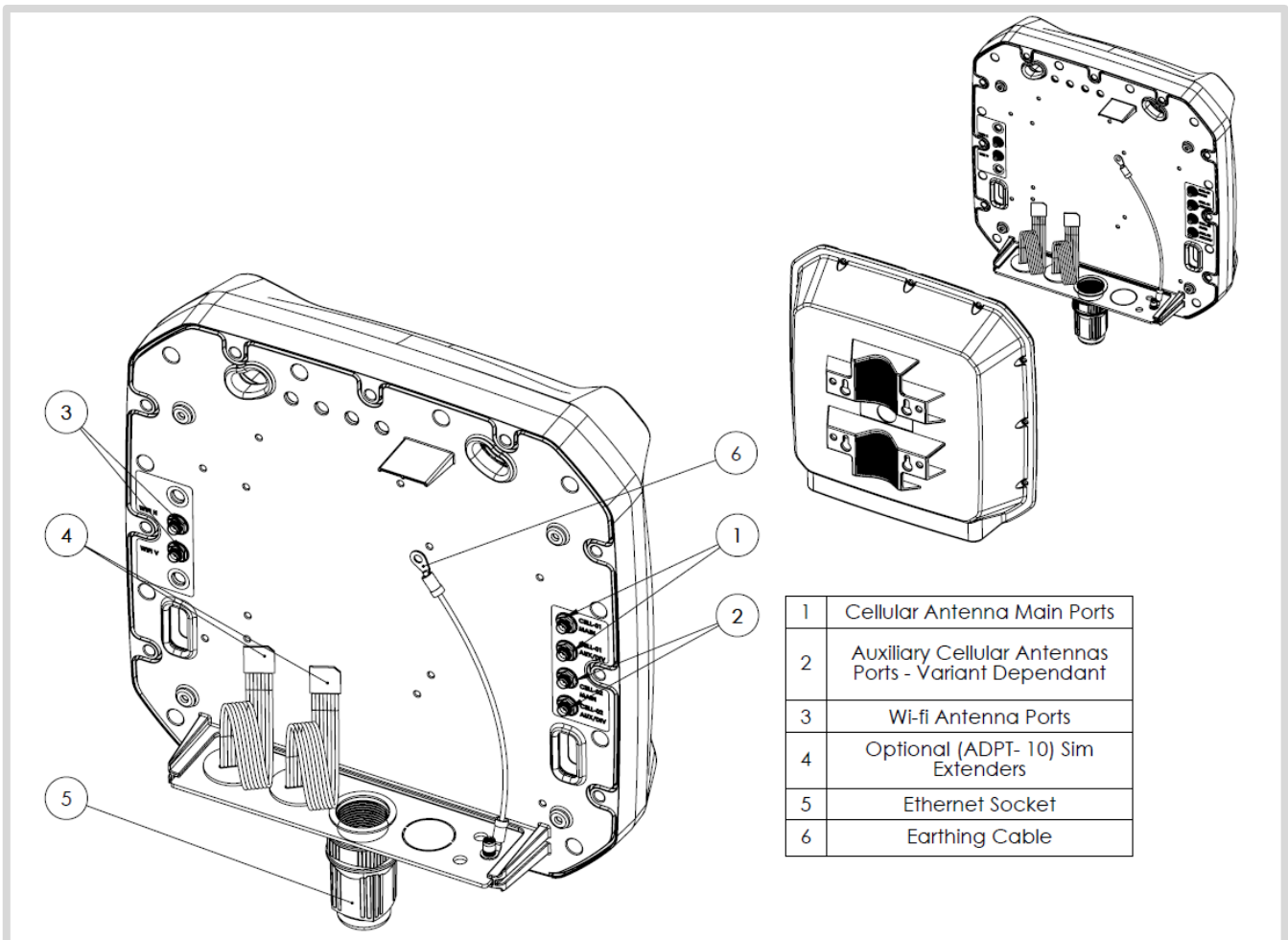
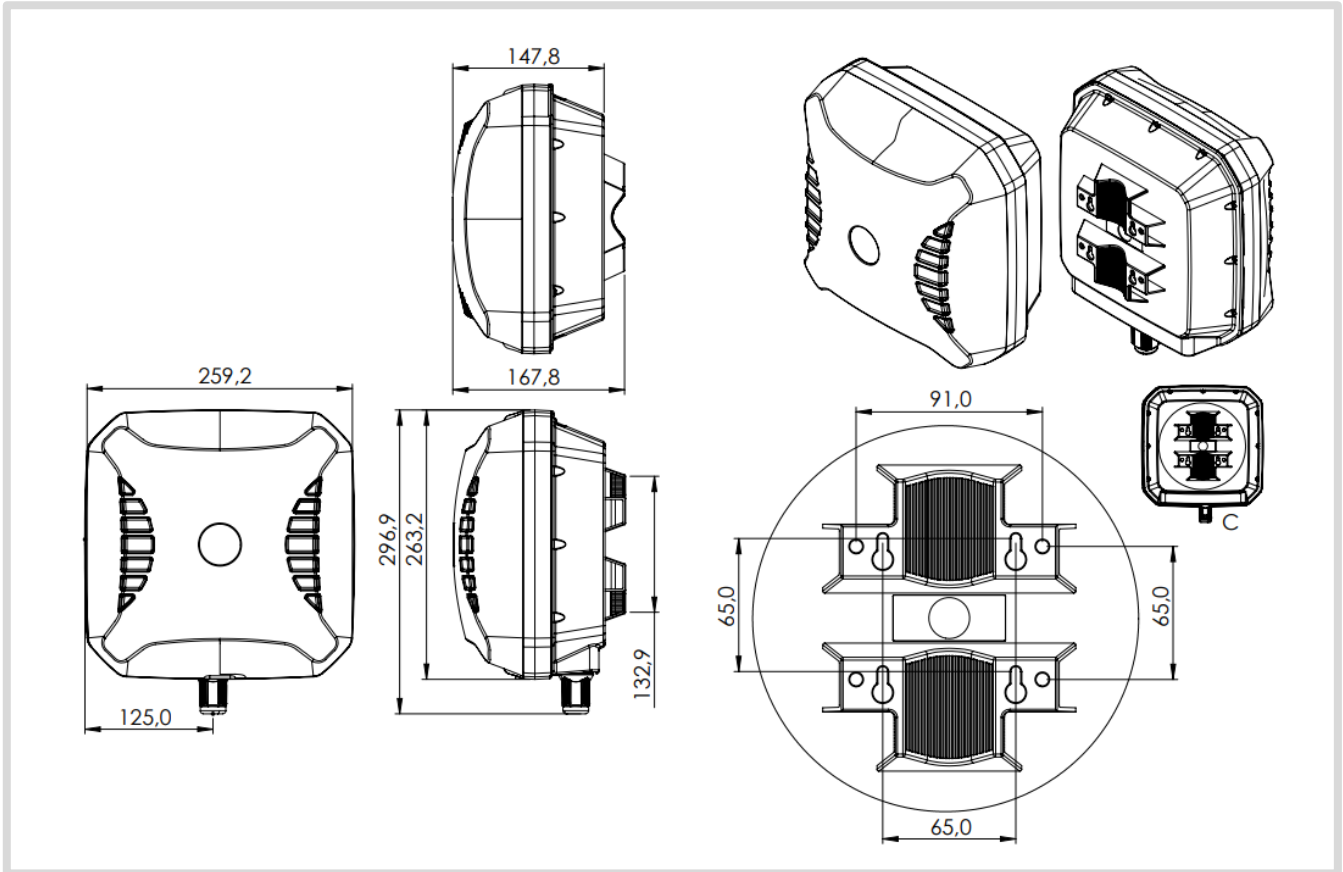

GENERIC ROUTER  
MOUNTING HOLES SPACING

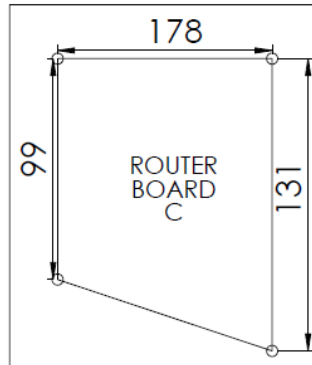
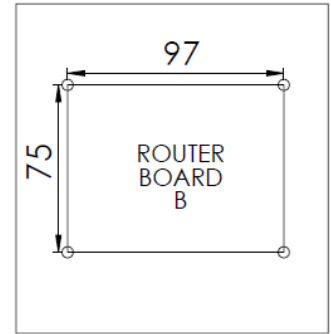
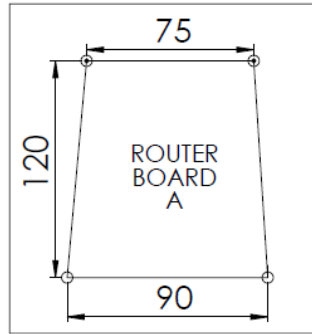
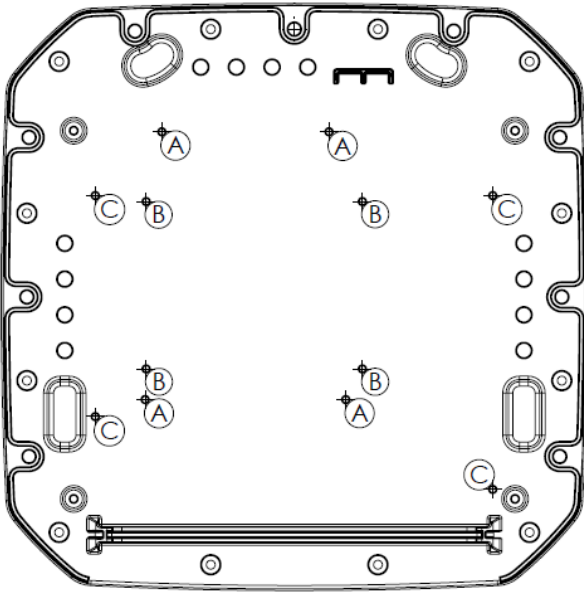

AVAILABLE SPACE  
FOR COMPATIBLE  
ROUTER  
ENCLOSURE

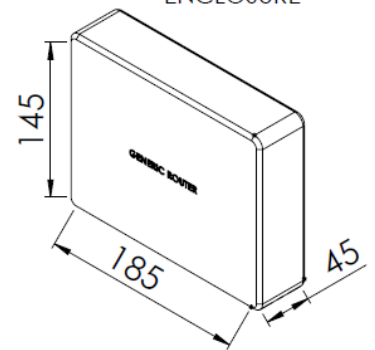

Radiation Patterns – Cellular

Azimuth: 617 - 960 MHz

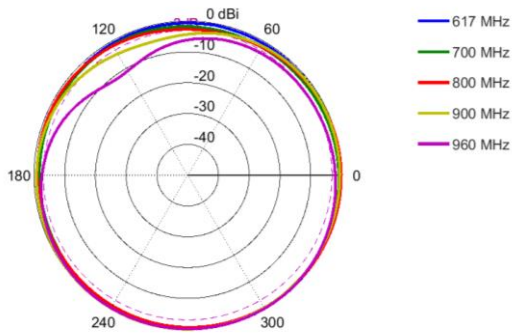

Azimuth: 1427 - 1517 MHz

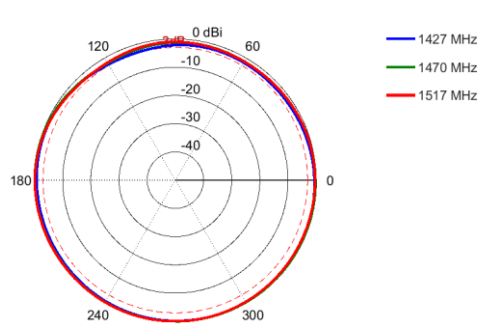

Azimuth: 1710 - 2170 MHz

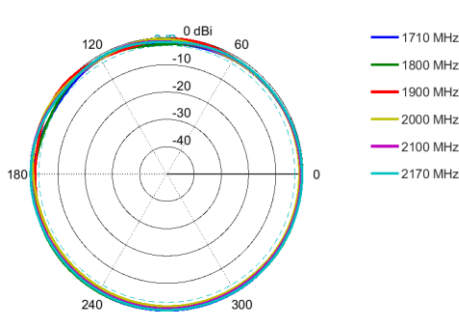

Azimuth: 2300 - 2700 MHz

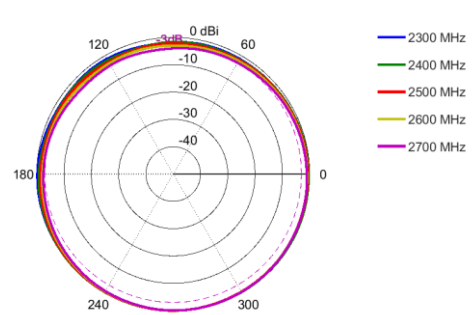

Azimuth: 3400 - 3800 MHz

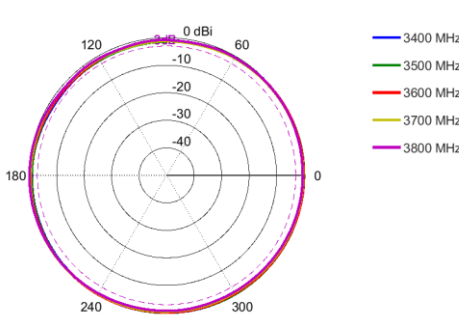

Elevation: 617 - 960 MHz

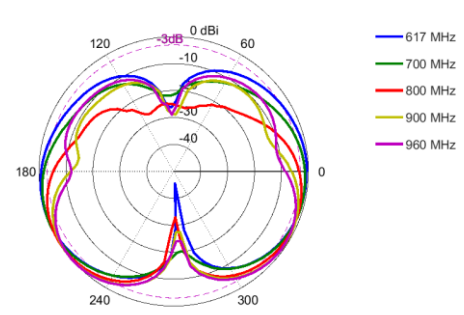

Elevation: 1427 - 1517 MHz

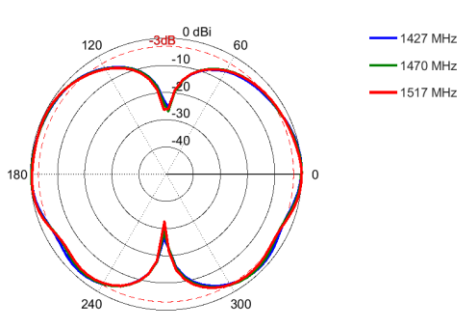

Elevation: 1710 - 2170 MHz

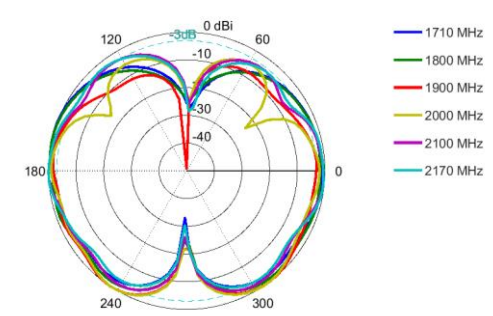

Elevation: 2300 – 2700 MHz

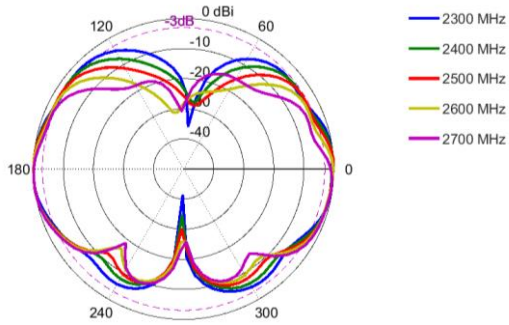

Elevation: 3400 - 3800 MHz

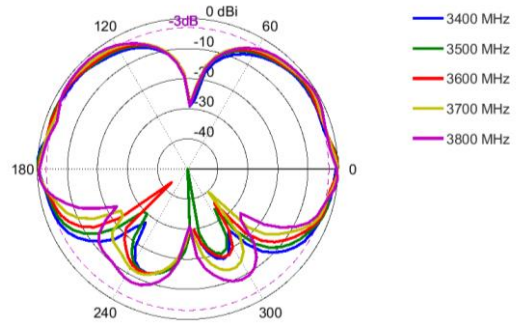

**Radiation Patterns – Wi-Fi**

Azimuth: 2400 - 2500 MHz

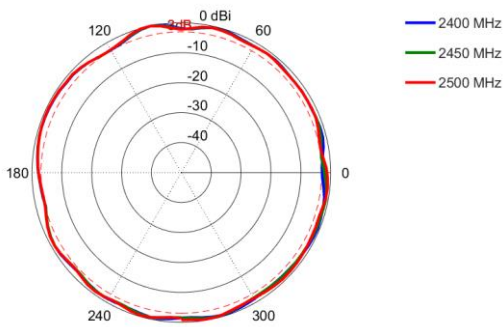

Azimuth: 5000 – 6000 MHz

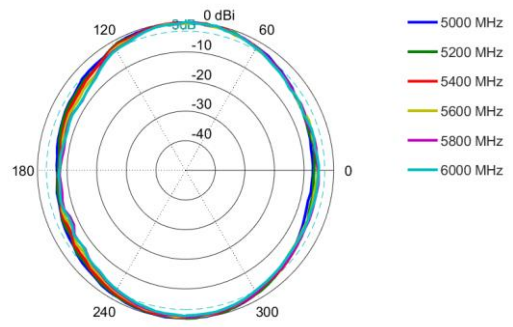

Azimuth: 6300 – 7200 MHz

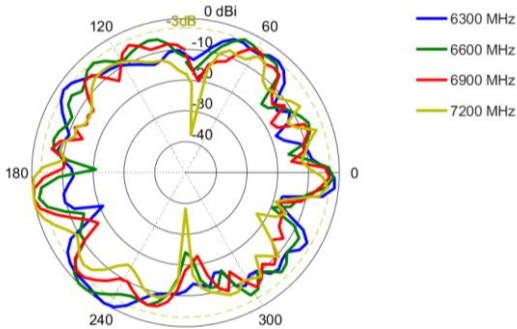

Elevation: 2400 - 2500 MHz

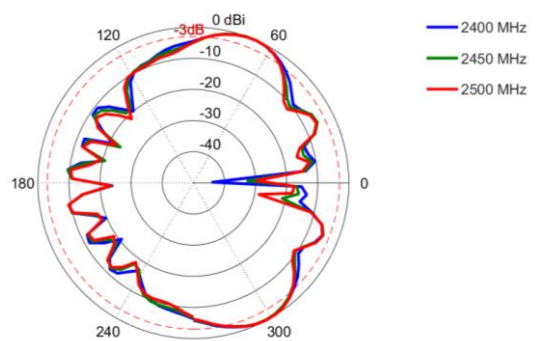

Elevation: 5000 – 6000 MHz

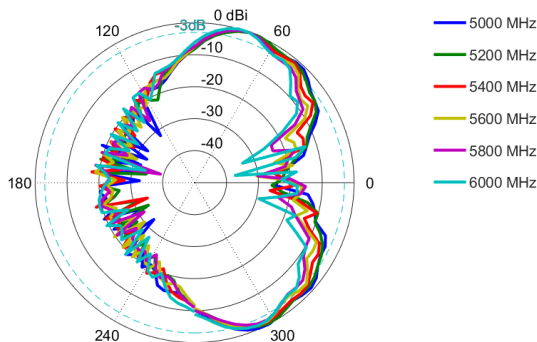

Elevation: 6300 – 7200 MHz

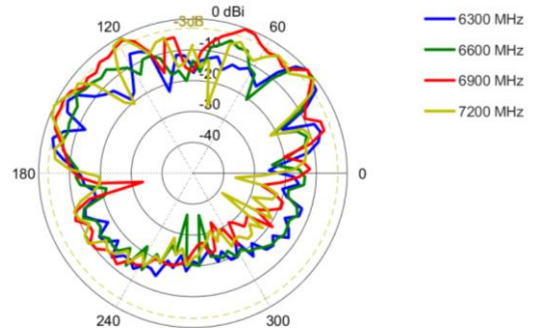

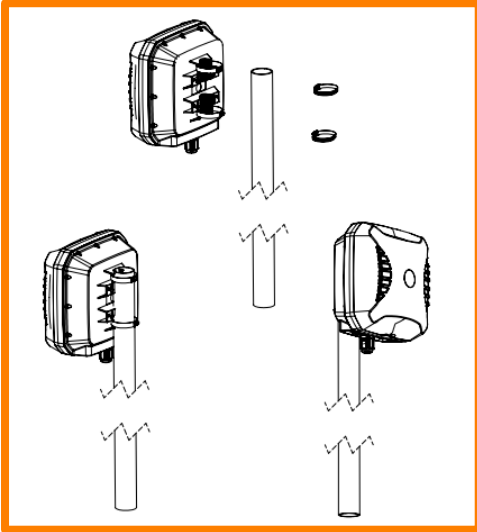

**Mounting Options**

**Pole Mount**

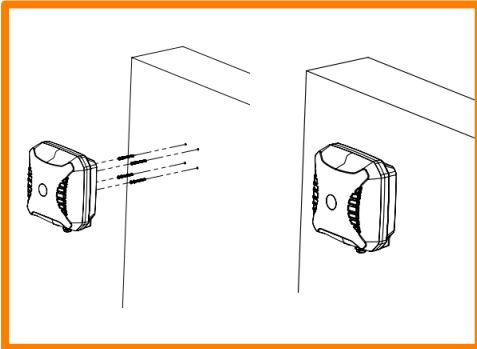
Pole mounting bracket using pipe clamps (included)

**Wall Mount**

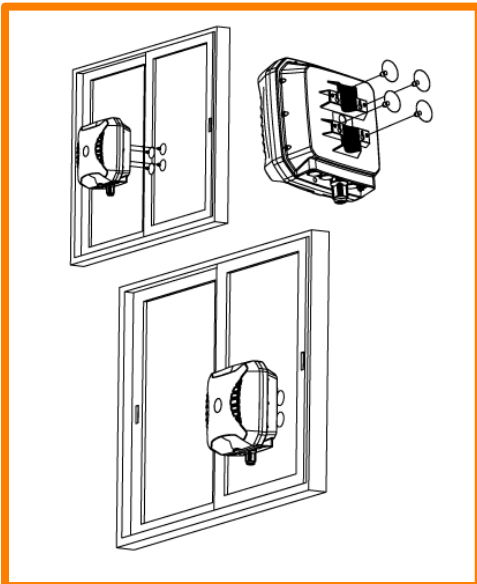
Wall mounting bracket using knock-in screws (included)

**Window Mount\***

Pole/Wall mounting bracket using window suckers (included)

*\* Window mounting using suckers is a temporary solution provided for convenience. Ensure that the grounding cable used is strong enough to double as a safety fallback. For sturdier long-term mounting, consider the wall/pole mount options.*

## Additional Accessories



**A-ADPT-010**

SIM Extender



### Various fly leads/pigtails available

- A-CAB-156: 250mm RG178 MCX (M) to RA SMA (M) Cable Assembly
- A-CAB-157: 250mm RG178 MMCX (M) to RA SMA (M) Cable Assembly
- A-CAB-158: 250mm RG178 U.FL (M) to RA SMA (M) Cable Assembly
- A-CAB-159: 250mm RG178 RA SMA (M) to RA SMA (M) Cable Assembly
- A-CAB-160: 250mm RG178 RA RPSMA (M) to RA SMA (M) Cable Assembly
- A-CAB-161: 250mm 1.13mm Coaxial Cable MHF4 (F) to RA SMA (M) Cable Assembly

## CONTACT POYNTING

### Poynting Antennas (Pty) Ltd - Head Office

Unit 4, N1 Industrial Park,  
Landmarks Avenue,  
Samrand, 0157, South Africa

**Phone:** +27 (0) 12 657 0050

**E-mail:** info@poynting.tech

**International Email:** sales-global@poynting.tech

### Poynting Europe

Regus Business Center Neue Messe Riem  
Kronstadter Straße 4  
81677 München  
Germany

**Phone:** +49 89 7453 9002

**E-mail:** sales-europe@poynting.tech

### Poynting USA

1804 Owen Court, Suite 104,  
Mansfield,  
TX 76063  
USA

**Phone:** +1 817 533-8130

**E-mail:** sales-us@poynting.tech