

**data**video

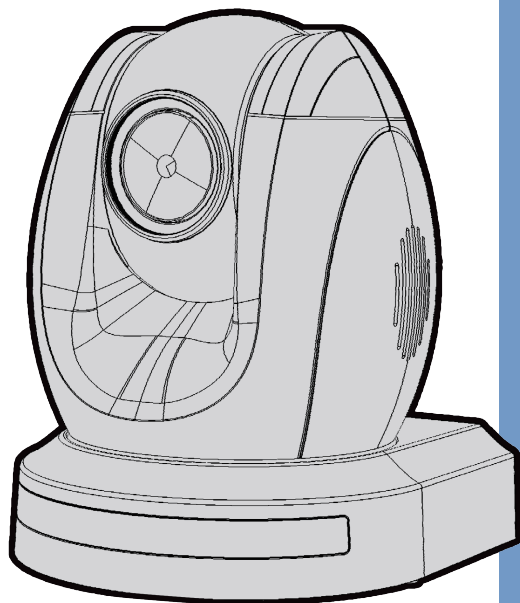

**HD/SD-SDI PTZ  
CAMERA**

**PTC-150/  
PTC-150W**

**Instruction Manual**

[www.datavideo.com](http://www.datavideo.com)

# Table of Contents

<b>FCC COMPLIANCE STATEMENT .....</b>	<b>4</b>
<b>WARNINGS AND PRECAUTIONS .....</b>	<b>4</b>
<b>WARRANTY .....</b>	<b>6</b>
<i>STANDARD WARRANTY .....</i>	<i>6</i>
<i>THREE YEAR WARRANTY .....</i>	<i>6</i>
<b>DISPOSAL .....</b>	<b>7</b>
<b>1. PRODUCT OVERVIEW .....</b>	<b>8</b>
<b>2. FEATURES .....</b>	<b>9</b>
<b>3. LOCATION AND FUNCTION OF PARTS .....</b>	<b>10</b>
<b>4. SYSTEM DIAGRAM .....</b>	<b>13</b>
<b>5. REMOTE CONTROL AND ON-SCREEN MENU .....</b>	<b>14</b>
5.1    REMOTE CONTROL FUNCTIONS .....	14
5.2    ON-SCREEN MENU .....	17
<b>6. INSTRUCTION FOR INSTALLATION .....</b>	<b>26</b>
STEP 1 – DIP SWITCH SETTING .....	26
STEP 2 – ONE END OF RETAINING WIRE .....	26
STEP 3 – CEILING BRACKET (B) .....	26
STEP 4 – CEILING BRACKET (A) AND CAMERA .....	27
STEP 5 – MOUNT CAMERA TO CEILING .....	29
STEP 6 – SCREW TO FIX CAMERA .....	30
STEP 7 – CABLE CONNECTION .....	30
<b>7. DIP SWITCH SETTINGS .....</b>	<b>31</b>
7.1    DIP SWITCH SW1 .....	31
7.2    DIP SWITCH SW2 (IRID) .....	32
<b>8. NETWORK CONFIGURATION .....</b>	<b>33</b>
<b>9. RMC-180 PTZ CAMERA CONTROL UNIT .....</b>	<b>38</b>
DIRECT CONNECTION TO CAMERA .....	38

<b>10. FIRMWARE UPDATE .....</b>	<b>39</b>
<b>11. FREQUENTLY-ASKED QUESTIONS.....</b>	<b>40</b>
<b>12. DIMENSIONS .....</b>	<b>41</b>
<b>13. SPECIFICATIONS.....</b>	<b>43</b>
<b>14. SERVICE &amp; SUPPORT .....</b>	<b>48</b>

**Disclaimer of Product and Services**

The information offered in this instruction manual is intended as a guide only. At all times, Datavideo Technologies will try to give correct, complete and suitable information. However, Datavideo Technologies cannot exclude that some information in this manual, from time to time, may not be correct or may be incomplete. This manual may contain typing errors, omissions or incorrect information. Datavideo Technologies always recommend that you double check the information in this document for accuracy before making any purchase decision or using the product. Datavideo Technologies is not responsible for any omissions or errors, or for any subsequent loss or damage caused by using the information contained within this manual. Further advice on the content of this manual or on the product can be obtained by contacting your local Datavideo Office or dealer.

## **FCC Compliance Statement**

This device complies with part 15 of the FCC rules. Operation is subject to the following two conditions:

- (1) This device may not cause harmful interference, and
- (2) This device must accept any interference received, including interference that may cause undesired operation.

## **Warnings and Precautions**

1. Read all of these warnings and save them for later reference.
2. Follow all warnings and instructions marked on this unit.
3. Unplug this unit from the wall outlet before cleaning. Do not use liquid or aerosol cleaners. Use a damp cloth for cleaning.
4. Do not use this unit in or near water.
5. Do not place this unit on an unstable cart, stand, or table. The unit may fall, causing serious damage.
6. Slots and openings on the cabinet top, back, and bottom are provided for ventilation. To ensure safe and reliable operation of this unit, and to protect it from overheating, do not block or cover these openings. Do not place this unit on a bed, sofa, rug, or similar surface, as the ventilation openings on the bottom of the cabinet will be blocked. This unit should never be placed near or over a heat register or radiator. This unit should not be placed in a built-in installation unless proper ventilation is provided.
7. This product should only be operated from the type of power source indicated on the marking label of the AC adapter. If you are not sure of the type of power available, consult your Datavideo dealer or your local power company.
8. Do not allow anything to rest on the power cord. Do not locate this unit where the power cord will be walked on, rolled over, or otherwise stressed.
9. If an extension cord must be used with this unit, make sure that the total of the ampere ratings on the products plugged into the extension cord do not exceed the extension cord's rating.
10. Make sure that the total amperes of all the units that are plugged into a single wall outlet do not exceed 15 amperes.
11. Never push objects of any kind into this unit through the cabinet ventilation slots, as they may touch dangerous voltage points or short out parts that could result in risk of fire or electric shock. Never spill liquid of any kind onto or into this unit.
12. Except as specifically explained elsewhere in this manual, do not attempt to service this product yourself. Opening or removing covers that are marked "Do Not Remove" may expose you to dangerous voltage points or

other risks, and will void your warranty. Refer all service issues to qualified service personnel.

13. Unplug this product from the wall outlet and refer to qualified service personnel under the following conditions:
  - a. When the power cord is damaged or frayed;
  - b. When liquid has spilled into the unit;
  - c. When the product has been exposed to rain or water;
  - d. When the product does not operate normally under normal operating conditions. Adjust only those controls that are covered by the operating instructions in this manual; improper adjustment of other controls may result in damage to the unit and may often require extensive work by a qualified technician to restore the unit to normal operation;
  - e. When the product has been dropped or the cabinet has been damaged;
  - f. When the product exhibits a distinct change in performance, indicating a need for service.

# Warranty

## ***Standard Warranty***

- Datavideo equipment are guaranteed against any manufacturing defects for one year from the date of purchase.
- The original purchase invoice or other documentary evidence should be supplied at the time of any request for repair under warranty.
- The product warranty period begins on the purchase date. If the purchase date is unknown, the product warranty period begins on the thirtieth day after shipment from a Datavideo office.
- All non-Datavideo manufactured products (product without Datavideo logo) have only one year warranty from the date of purchase.
- Damage caused by accident, misuse, unauthorized repairs, sand, grit or water is not covered under warranty.
- Viruses and malware infections on the computer systems are not covered under warranty.
- Any errors that are caused by unauthorized third-party software installations, which are not required by our computer systems, are not covered under warranty.
- All mail or transportation costs including insurance are at the expense of the owner.
- All other claims of any nature are not covered.
- All accessories including headphones, cables, and batteries are not covered under warranty.
- Warranty only valid in the country or region of purchase.
- Your statutory rights are not affected.

## ***Three Year Warranty***

- All Datavideo products purchased after July 1st, 2017 are qualified for a free two years extension to the standard warranty, providing the product is registered with Datavideo within 30 days of purchase.
- Certain parts with limited lifetime expectancy such as LCD panels, DVD drives, Hard Drive, Solid State Drive, SD Card, USB Thumb Drive, Lighting, Camera module, PCIe Card are covered for 1 year.
- The three-year warranty must be registered on Datavideo's official website or with your local Datavideo office or one of its authorized distributors within 30 days of purchase.



## Disposal

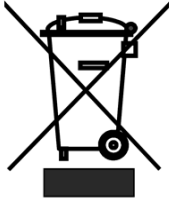

### **For EU Customers only - WEEE Marking**

This symbol on the product or on its packaging indicates that this product must not be disposed of with your other household waste. Instead, it is your responsibility to dispose of your waste equipment by handing it over to a designated collection point for the recycling of waste electrical and electronic equipment. The separate collection and recycling of your waste equipment at the time of disposal will help to conserve natural resources and ensure that it is recycled in a manner that protects human health and the environment. For more information about where you can drop off your waste equipment for recycling, please contact your local city office, your household waste disposal service or the shop where you purchased the product.



**CE Marking** is the symbol as shown on the left of this page. The letters "CE" are the abbreviation of French phrase "Conformité Européene" which literally means "European Conformity". The term initially used was "EC Mark" and it was officially replaced by "CE Marking" in the Directive 93/68/EEC in 1993. "CE Marking" is now used in all EU official documents.

# 1. Product Overview

The PTC-150/PTC-150W HD/SD Video Camera is a PTZ camera that can be mounted on a wall, ceiling, floor, or a tabletop, and includes an IR remote control. The camera captures HD video at 1920 x 1080 resolution, and features wide dynamic range with backlight compensation. The camera features a motorized 30x optical zoom capability. The camera's image mirror and image rotation functions allow you to electronically adjust the image and deliver a correctly oriented image.

50 programmable presets including pan, tilt, and zoom positions, allow the camera to quickly move between predetermined camera positions using the remote.

For multi-camera shoots, the built-in tally light can identify when the camera is active. The camera features a built-in IR cut filter in the image path for low light shooting, and then returns for daytime shooting. Moreover, PTC-150/PTC-150W supports real time position report on a per frame basis; this will be helpful to virtual studio application. The camera supports Sony VISCA protocol for PTZ control using RS-422 interface over the unit's RJ-45 port.



## 2. Features

- HD Resolution: 1/2.8" High Definition 2.14 M Pixels progressive CMOS sensor
- 30x optical zoom (f = 4.3 mm to 129 mm)
- High definition formats supported: 1080/59.94p, 1080/50p, 1080/59.94i, 1080/29.97p, 1080/25p, 1080/50i, 720/59.94p, 720/50p
- Standard definition formats supported: 480i, 576i
- Digital Noise Reduction Function (DNR) to reduce the noise and enable clearer image under low light conditions.
- Position coordinates report in real time per frame.
- Video Output: HD-SDI + CVBS + HDMI synchronously.
- Tally LED Design
- Supports VISCA Protocol Keyboard
- Supports DVIP Control Protocol

### 3. Location and Function of Parts

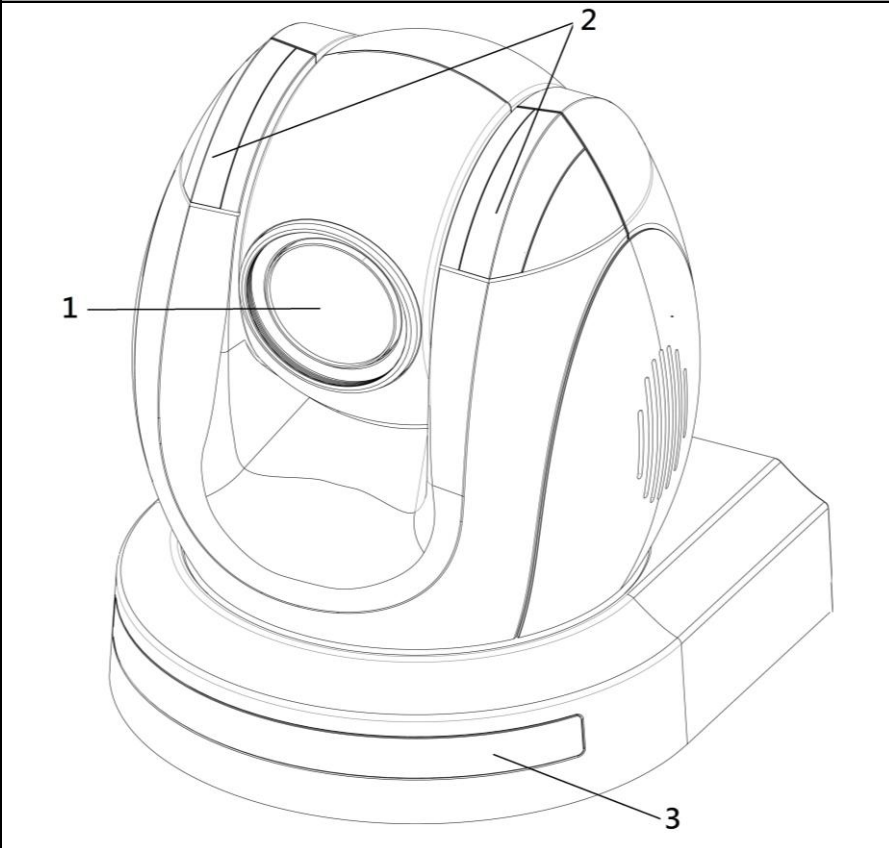
Front of Camera	
	
1	<b>Lens</b> Built-in 1/2.8" 2.14M Pixel CMOS HD color camera with white balance control, backlight compensation settings, automatic gain settings and etc.
2	<b>Tally LED</b> Tally lamp lights up when tally signal has been transmitted to the tally signal box.
3	<b>Sensor for Remote Control</b> Remote controller receiver

## Rear of Camera

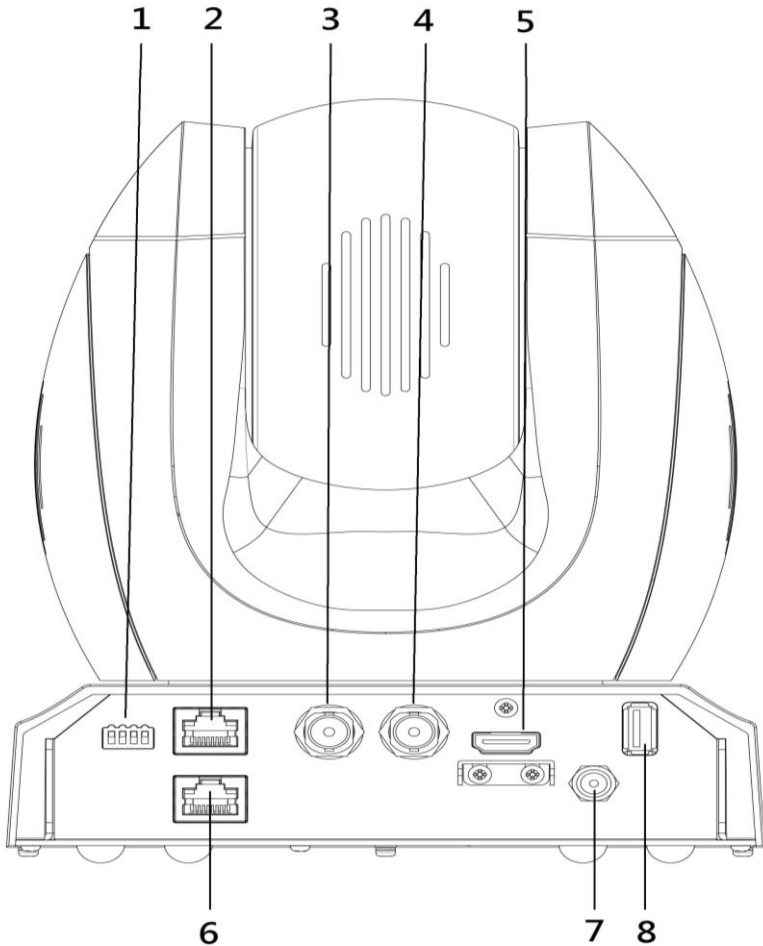

1	<b>DIP Switch SW2</b> DIP switch for IRID setting. <i>See the <a href="#">DIP Switch Settings</a> section for details.</i>
2	<b>RS422 Communication Port</b> Connection to the RMC-180 PTZ Camera Control Unit for remote control of the camera via any RJ-45 cable. <i>See <a href="#">Section 9</a> for physical connection to the RMC-180. For details on how to use the RMC-180, please read the RMC-180 instruction manual.</i>

3	<b>HD-SDI OUT</b> Video signal output
4	<b>CVBS OUT</b> Video signal output
5	<b>HDMI OUT</b> Video signal output
6	<b>HDBaseT Communication Port</b> Connects the camera to the receiver box, thereby extending video transmission up to 100m.  <b>Note:</b> If the camera is used as a standalone device, this port can be used to connect the camera directly to the PC or to a network router via any RJ-45 cables. <i>See <a href="#">Section 8</a> for configuring the camera's network settings using the DVIP Network Configuration Tool.</i>
7	<b>Power Input</b> DC in socket connects the supplied 12V PSU. The connection can be secured by screwing the outer fastening ring of the DC In plug to the socket.
8	<b>USB Port</b> The USB port is used for F/W Upgrade Only. Insert a USB stick containing the latest firmware files into this port. <i>See <a href="#">Section 10</a> for Firmware Update Procedure.</i>

### Bottom of Camera

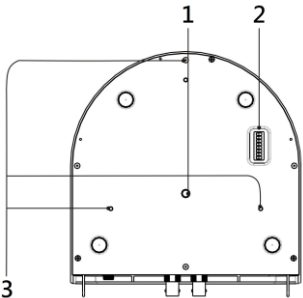
	1	<b>Tripod Screw Hole</b> allows the user to mount the camera on the tripod.
	2	<b>DIP Switch SW1</b> Camera settings include <b>VISCA ID</b> , <b>Remote Control Protocol</b> , <b>Resolution</b> and <b>Video Mode Selection Method</b> . <i>See the <a href="#">DIP Switch Settings</a> section for details.</i>
	3	<b>Screw Hole</b> Screw holes for ceiling bracket mounting. <i>See <a href="#">Section 6</a> for installation instructions.</i>

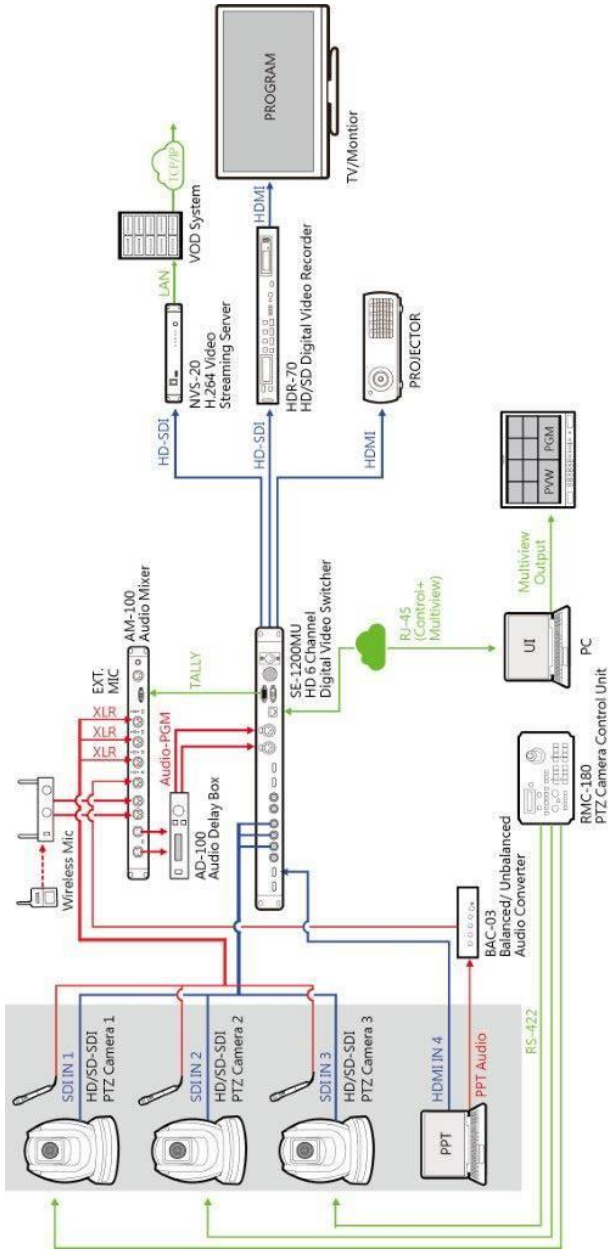

# 4. System Diagram





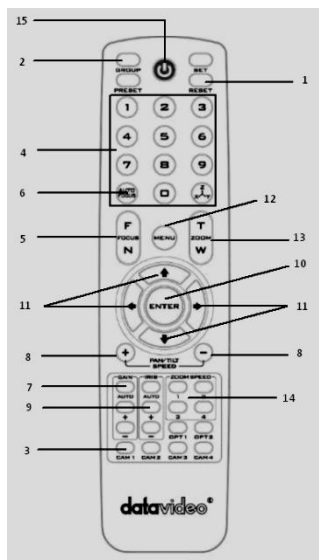



# 5. Remote Control and On-Screen Menu





## 5.1 Remote Control Functions

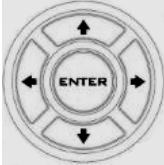

No	Item	Description
1		Press <b>RESET</b> button to return the camera lens to the front.
2		Use the No. bottom & the group bottom to select the group scan.  Press any of the No. buttons 1~8 and then press <b>GROUP</b> button.
3		<b>Select CAM1-CAM4 in a multi-camera environment</b> Assign an ID number to the camera intended for operation by adjusting the IRID (SW2) switch located at the rear of the camera  Press CAMERA SELECT (CAM 1~CAM4) buttons corresponding to the numbers set previously to navigate between four cameras

No.	Item	Description
4		<p>Various combinations of settings (position, zoom, focus, gain control and iris control) can be saved to presets.</p> <p><b>Adjust Preset Point</b> Adjust position, zoom, focus, gain control and iris of the camera.</p> <p><b>Set up Preset Point</b> Press any of the POSITION buttons 1~50 and then press SET button.</p> <p><b>Recall saved setting</b> Press any of the POSITION buttons 1~50 and then press PRESET button.</p> <p><b>Set up Group Scan mode</b> Press any of the POSITION buttons 1~8 and then press GROUP button.</p> <p><b>Return Camera Lens back to Front</b> Press number 0 and then press PRESET button.</p>

5	<p style="text-align: center;"><b>Focus Setup</b></p> 	<p><b>Manually focus camera lens on a subject</b>  Press either (F) FAR button or (N) NEAR button to manually focus the camera lens onto the subject.</p>
6	<p style="text-align: center;"><b>Auto Focus Control</b></p> 	<p><b>Automatically focus camera lens on a subject</b>  Press A/ FOCUS button. Camera lens will be automatically focused on the subject such that it is positioned at the center of the screen.</p> <p><b>Exit Sub-Menu Option</b>  Press A/ FOCUS button to exit sub-menu option</p>
7	<p style="text-align: center;"><b>Gain Control</b></p> 	<p><b>Adjust Brightness</b>  Press GAIN+ button to increase the brightness or GAIN- button to decrease the brightness of the environment.</p> <p>To cancel the function or return to default setup, press A/ GAIN button.</p>
8	<p style="text-align: center;"><b>P/T Speed</b></p> 	<p><b>Adjust Pan/ Tilt Speed</b>  Press SPEED + / - button to switch to different speed (up/down)</p>
9	<p style="text-align: center;"><b>Auto Iris Control</b></p> 	<p><b>Make the subject appear brighter</b>  Adjust the iris opening (aperture), to control the amount of light coming through the lens (i.e. the "exposure"). Press IRIS+ button to enlarge the iris opening to allow more light to come in so that the subject appears brighter and press IRIS- button to shrink the iris opening to allow less light to come in so that the subject appears less bright.</p> <p>To cancel the function or return to default setup, press A/IRIS button.</p>
10	<p style="text-align: center;"><b>ENTER</b></p> 	<p><b>ENTER</b>  Menu ENTER key</p>

11	<p><b>Direction Arrows</b></p> 	<p><b>Change camera direction</b> Press arrow buttons to change the direction of the camera head</p> <p><b>Stop Preset Point Auto Scan mode</b> Press any of the DIRECTION buttons</p> <p><b>Select Menu Option</b> Press UP or DOWN button to select the menu option</p> <p><b>Adjust P/T Speed</b> Press UP or DOWN button to adjust the PAN/TILT Speed</p> <p><b>Enter Sub-Menu Option</b> Press ENTER button to enter sub- menu option</p> <p><b>Adjust Setup Value</b> Press LEFT or RIGHT button to adjust the value</p>
12	<p><b>Enter/ Exit Camera Menu</b></p> 	<p><b>Enter or Exit Camera Menu Option</b></p>
13	<p><b>Zoom In/Out Buttons</b></p> 	<p><b>Zoom</b> Press either (T) TELE button to zoom in on the subject such that it appears to be close to the camera or (W) WIDE button to zoom out from the subject such that it appears to be far away from the camera.</p>
14	<p><b>Zoom Speed Button (4 speed selection)</b></p> 	<p><b>Adjust Zoom In/Out Speed</b> Press this button to switch to different speed (The Highest~ The Lowest)</p>
15	<p><b>Power Button</b></p> 	<p><b>Switch Remote Controller ON/OFF</b></p>



## 5.2 On-Screen Menu

On-Screen Menu allows the user to change various camera settings such as shooting conditions and the system setup. Press **[Menu]** on the **remote control** to enter the on-screen menu as shown below.

On-Screen MENU
1: Camera Set (Normal)
2: Memory
3: Video Output
4: Remote Control
5: System
6: Camera Set (Advance)
7: Reset P/T/Z
8: Escape

The following table lists all the sub-options of the options on the main menu.

Main Options								
Camera Set (Normal)	Memory	Video Output	Remote Control	System	Camera Set (Advance)	Reset P/T/Z	Escape	
Sub-Options	1. Camera Name	1. Preset Position	1. Selection Way	1. PAN/TILT Reverse	1. Display	1. Camera Name	Reset P/T/Z	
	2. Mirror	2.Group-1	2. Video Mode	2. Remote Source	2. Set Motor	2. Mirror		
	3. White Balance	3. Group-2	3. CV Mode	3. Set RS-422	3. Tally Light	3. White Balance		
	4. Focus	4. Group-3	4. Pattern	4. Set DVIP	4. Reset All	4. Focus		
	5. Iris	5. Group-4	5. Escape	5. Set IR	5. Update Software	5. Iris		
	6. AGC	6. Group-5		6. PTZ INFO. output	6. Escape	6. AGC		
	7. Escape	7. Group-6		7. Escape		7. Fog Correction		
		8. Group-7				8. Aperture		
		9. Group-8				9. Vivid Effect		
		10. Escape				10. Pedestal Effect		
						11. Backlight Correct		
						12. Day/Night Mode		
						13. Shutter		
						14. Gamma Mode		
						15. WD Mode		
						16. Escape		

Details of all options in the on-screen menu are listed in the table below.

First Level Main Options	Second Level Sub-Options	Third Level Parameters	Fourth Level Parameters	Sub-Option Descriptions		
<b>1. Camera Set (Normal)</b>	1. Camera Name	NAME				
		DISPLAY SW	ON/OFF			
		POSITION	LOWER LEFT UPPER RIGHT			
		ESCAPE				
	2. Mirror	H+V				
		V				
		H				
		OFF				
	3. White Balance	MODE		AWB(AUTO) AWC (ONE PUSH) MWB (MANUAL) 3200K (INDOOR) 6500K (OUTDOOR) 4200K (FLUO)		
			SMART ATW	OFF SMART1/2/3		
			MWB RED COMPONENT	0~128~255		
			MWB BLUE COMPONENT	0~128~255		
			ESCAPE			
			4. Focus	FOCUS MODE	AUTO MANUAL	
		AF SENSITIVITY		LOW NORMAL		
		FOCUS SPEED		1~4		
	ESCAPE					
	5. Iris	IRIS MODE	AUTO IRIS MANUAL			
			MANUAL IRIS LEVEL	F1.6 F2.0 F2.4 F2.8 F3.4 F4 F4.8 F5.6 F6.8 F8 F9.6 F11 F14 CLOSE		
		ESCAPE				
		6. AGC		DAY (COLOR) AGC	AGC MODE	OFF ON
					MANUAL GAIN	0 dB ~ GAIN LIMIT 9 dB
					GAIN LIMIT	12 dB 15 dB

			18 dB	
			21 dB	
			24 dB	
			27 dB	
			30 dB	
			33 dB	
			36 dB	
			39 dB	
			ESCAPE	
			DNR	
OFF				
DNR LEVEL	0			
	1			
	2			
	3			
	4			
	5			
ESCAPE				
ESCAPE				
7. Escape				
<b>2. Memory</b>	1. Preset Position	1-50	P	
			T	
			Z	
		51	ESCAPE	
	2. Group – 1	1-16	PRESET NO.	1~50
			ITEM ON/OFF	ON/OFF
			SPEED LIMIT	1~18
			WAITING TIME	0~180
			NEXT POSITION	NEXT TIME
				RETURN
				GROUP – 1
				GROUP – 2
				GROUP – 3
				GROUP – 4
				GROUP – 5
	GROUP – 6			
	GROUP – 7			
GROUP – 8				
ESCAPE				
17. ESCAPE				
3. Group – 2	1-16	PRESET NO.	1~50	
		ITEM ON/OFF	ON/OFF	
		SPEED LIMIT	1~18	
		WAITING TIME	0~180	
		NEXT POSITION	NEXT TIME	
			RETURN	
			GROUP – 1	
			GROUP – 2	
			GROUP – 3	
			GROUP – 4	
			GROUP – 5	
GROUP – 6				
GROUP – 7				
GROUP – 8				
ESCAPE				
17. ESCAPE				
4. Group – 3	1-16	PRESET NO.	1~50	

			ITEM ON/OFF	ON/OFF
			SPEED LIMIT	1~18
			WAITING TIME	0~180
			NEXT POSITION	NEXT TIME
				RETURN
				GROUP - 1
				GROUP - 2
				GROUP - 3
				GROUP - 4
				GROUP - 5
				GROUP - 6
			GROUP - 7	
			GROUP - 8	
			ESCAPE	
17. ESCAPE				
5. Group - 4	1-16		PRESET NO.	1~50
			ITEM ON/OFF	ON/OFF
			SPEED LIMIT	1~18
			WAITING TIME	0~180
			NEXT POSITION	NEXT TIME
				RETURN
				GROUP - 1
				GROUP - 2
				GROUP - 3
				GROUP - 4
				GROUP - 5
				GROUP - 6
			GROUP - 7	
			GROUP - 8	
ESCAPE				
17. ESCAPE				
6. Group - 5	1-16		PRESET NO.	1~50
			ITEM ON/OFF	ON/OFF
			SPEED LIMIT	1~18
			WAITING TIME	0~180
			NEXT POSITION	NEXT TIME
				RETURN
				GROUP - 1
				GROUP - 2
				GROUP - 3
				GROUP - 4
				GROUP - 5
				GROUP - 6
			GROUP - 7	
			GROUP - 8	
ESCAPE				
17. ESCAPE				
7. Group - 6	1-16		PRESET NO.	1~50
			ITEM ON/OFF	ON/OFF
			SPEED LIMIT	1~18
			WAITING TIME	0~180
			NEXT POSITION	NEXT TIME
				RETURN
				GROUP - 1
				GROUP - 2
			GROUP - 3	
			GROUP - 4	

				GROUP - 5	
				GROUP - 6	
				GROUP - 7	
				GROUP - 8	
			ESCAPE		
	17. ESCAPE				
8. Group - 7	1-16	PRESET NO.	1~50		
		ITEM ON/OFF	ON/OFF		
		SPEED LIMIT	1~18		
		WAITING TIME	0~180		
		NEXT POSITION	NEXT TIME		
			RETURN		
			GROUP - 1		
			GROUP - 2		
			GROUP - 3		
			GROUP - 4		
			GROUP - 5		
			GROUP - 6		
		GROUP - 7			
		GROUP - 8			
ESCAPE					
17. ESCAPE					
9. Group - 8	1-16	PRESET NO.	1~50		
		ITEM ON/OFF	ON/OFF		
		SPEED LIMIT	1~18		
		WAITING TIME	0~180		
		NEXT POSITION	NEXT TIME		
			RETURN		
			GROUP - 1		
			GROUP - 2		
			GROUP - 3		
			GROUP - 4		
			GROUP - 5		
			GROUP - 6		
		GROUP - 7			
		GROUP - 8			
ESCAPE					
17. ESCAPE					
10. Escape					
3. Video Output	1. Selection Way	BY MENU			
		BY SWITCH			
	2. Video Mode	1080i60			
		1080i50			
		720p60			
		720p50			
		1080p29.97			
		1080p25			
		1080p59.94			
	1080p50				
	3. CV Mode	16:9			
		4:3			
	4. Pattern	OFF			
COLOR BAR					
5. Escape					
4. Remote	1. PAN/TILT Reverse	OFF			
		P			

<b>Control</b>		T		
		P+T		
	2. Remote Source	RS-422, SW <b>(Configurable using bottom DIP switch ONLY)</b>		
	3. Set RS-422	CAMERA ID MODE	BY MENU BY SWITCH	
		CAMERA ID	1~7	
		RS-422 BAUD RATE	9600	
			19200	
			38400	
	115200			
	ESCAPE			
4. Set DVIP	DVIP BAUD RATE	9600		
		19200		
		38400		
		57600		
	115200			
ESCAPE				
5. Set IR	IR GROUP ID <b>(Configurable using rear DIP switch ONLY)</b>	CAM1~4		
	ESCAPE			
6. PTZ INFO. Output	ON/OFF			
7. Escape				
<b>5. System</b>	1. Display	P/T/Z OSD	PAN OSD	ON/OFF
			TILT OSD	ON/OFF
			ZOOM OSD	ON/OFF
			ESCAPE	
		DEBUG OSD	DEBUG IR OSD	ON/OFF
			DEBUG CAM. OSD	ON/OFF
			DEBUG RS-422 OSD	ON/OFF
			DEBUG DVIP OSD	ON/OFF
			DEBUG M_CTL OSD	ON/OFF
	DEBUG REG OSD		ON/OFF	
	DEBUG FRAME NO		ON/OFF	
	PWR ON CAM TEST	ON/OFF		
	ESCAPE			
	2. Set Motor	PAN torque ADJ	LOW	
			+1~+5	
		TILT torque ADJ	LOW	
			+1~+5	
		PAN offset ADJ	+5.4	
			+4.5	
			+3.6	
			+2.7	
+1.8				
+0.9				
0.0				
-0.9				
-1.8				
-2.7				
-3.6				
-4.5				
-5.4				
TILT offset ADJ	+6.3			

			+5.4		
			+4.5		
			+3.6		
			+2.7		
			+1.8		
			+0.9		
			0.0		
			-0.9		
			-1.8		
			-2.7		
			-3.6		
			-4.5		
			-5.4		
			-6.3		
		ESCAPE			
	3. Tally Light	RED/GREEN			
		GREEN			
		RED			
		OFF			
	4. Reset All	YES/NO			
	5. Update Software	SW VERSION	ESCAPE		
		MB CPU	V01.17i		
		MB FPGA	V017		
		MCTL CPU	V00.42		
		UPDATE ALL	YES/NO		
		ESCAPE			
	6. Escape				
<b>6. Camera Set (ADVANCE)</b>	1. Camera Name	NAME			
		DISPLAY SW	ON/OFF		
		POSITION	UPPER LEFT		
			LOWER LEFT		
			UPPER RIGHT		
	LOWER RIGHT				
		ESCAPE			
	2. Mirror	H+V			
		V			
		H			
		OFF			
	3. White Balance	MODE	AWB (AUTO)		
			AWC (ONE PUSH)		
			MWB (MANUAL)		
			3200K (INDOOR)		
			6500K (OUTDOOR)		
		4200K (FLUO)			
		SMART ATW (Enabled in AWB (AUTO) mode)	OFF		
		SMART1~3			
		MWB RED COMPONENT	0~128~255		
		MWB BLUE COMPONENT	0~128~255		
		ESCAPE			
	4. Focus	FOCUS MODE	AUTO		
			MANUAL		
		AF SENSITIVITY	LOW		
			NORMAL		
		FOCUS SPEED	1		

			2	
			3	
			4	
		ESCAPE		
	5. Iris	IRIS MODE	AUTO	
			MANUAL	
		Manual IRIS LEVEL	F1.6	
			F2.0	
			F2.4	
			F2.8	
			F3.4	
			F4	
			F4.8	
			F5.6	
			F6.8	
			F8	
			F9.6	
			F11	
	F14			
	CLOSE			
	ESCAPE			
	6. AGC	DAY (COLOR) AGC	AGC MODE	ON/OFF
			MANUAL GAIN	0dB~GAIN LIMIT
			GAIN LIMIT	9 dB
				12 dB
				15 dB
				18 dB
21 dB				
24 dB				
27 dB				
30 dB				
33 dB				
36 dB				
39 dB				
ESCAPE				
DNR		DNR(AT AGC ON)	ON	
	OFF			
	DNR LEVEL	0		
		1		
		2		
		3		
4				
5				
ESCAPE				
7. Fog Correction	FOG CORRECTION	OFF/ON		
	ESCAPE			
8. Aperture	0~15			
9. Vivid Effect	0~14			
10. Pedestal Effect	0~14 <b>(This option is enabled after AGC is turned on)</b>			
11. Backlight Correction	OFF/ON <b>(This option is enabled after AGC is turned on)</b>			



	12. Day/Night Mode	B/W			
		COLOR			
	13. Shutter	SHUTTER SPEED	NORMAL		
			1/100		
			1/125		
			1/250		
			1/500		
		1/1000			
		ESCAPE			
	14. Gamma Mode	STANDARD MODE1 (WD OFF) MODE2 (WD OFF) MODE3 (WD OFF) MODE4 (WD OFF)			
15. WD Mode	ON/OFF <b>(This option is enabled after AGC is turned on)</b>				
16. Escape					
<b>7. Reset P/T/Z</b>	Reset P/T/Z	YES/NO			
<b>8. Escape</b>					

## Descriptions of Advanced Functions

**Fog Correction:** This function restores clarity of images degraded by fog, haze or dust and is particularly useful for video surveillance and related applications.

**Aperture:** The Aperture is the opening in the lens through which light passes to enter the camera. The Aperture option allows users to adjust the size of the opening.

**Vivid Effect:** The Vivid Effect is basically the saturation of the image. Increasing the value of the vivid effect increases the image saturation, and vice versa.

**Pedestal Effect:** The Pedestal Effect adjusts the brightness in Auto Iris mode. Before tuning the brightness using this option, make sure the AGC is enabled. Increasing the value increases the image brightness, and vice versa.

**Backlight:** Enabling the backlight brightens the dark portion of the image.

**WD Mode:** Enabling the WD mode balances the light in the image to show more details of the image. This brightens the dark portion of the image and darkens the bright portion of the image. Before enabling the WD Mode, make sure the AGC is turned on.

## 6. Instruction for installation

### Step 1 – DIP Switch Setting

Set the Mirror option to H+V mode.

### Step 2 – One End of Retaining Wire

Attach the retaining wire to the junction box mounted on the ceiling by screwing one end of the retaining wire into a screw hole in the junction box with a screw (not supplied) as shown in the diagram below.

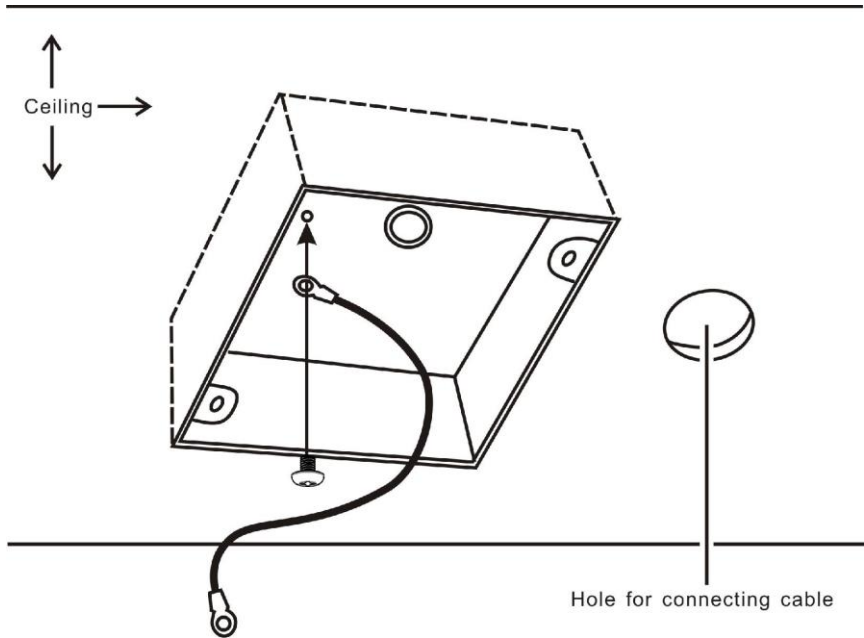

### Step 3 – Ceiling Bracket (B)

- Again, as illustrated in the diagram below, screw a ceiling bracket (B) into the junction box mounted on the ceiling.
- Make sure the screw holes of the ceiling bracket (B) are aligned with the holes on the junction box.

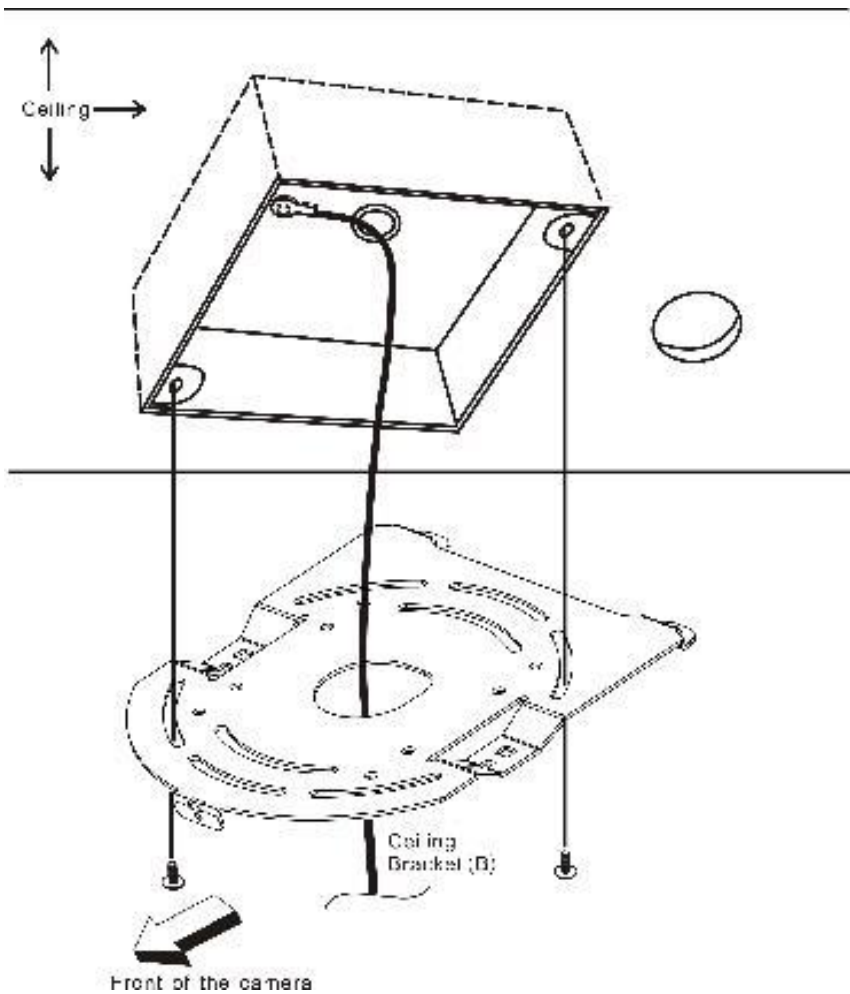

#### Step 4 – Ceiling Bracket (A) and Camera

- Screw ceiling bracket (A) into the bottom of the camera using three screws.
- Position the screws as shown in the diagram below.
- Align the screw holes on the bottom of the camera with those in the ceiling bracket.
- Insert the screws into the corresponding screw holes in the numbered order.
- The other end of the retaining wire is screwed into the screw hole #3.
- Securely tighten all three screws.

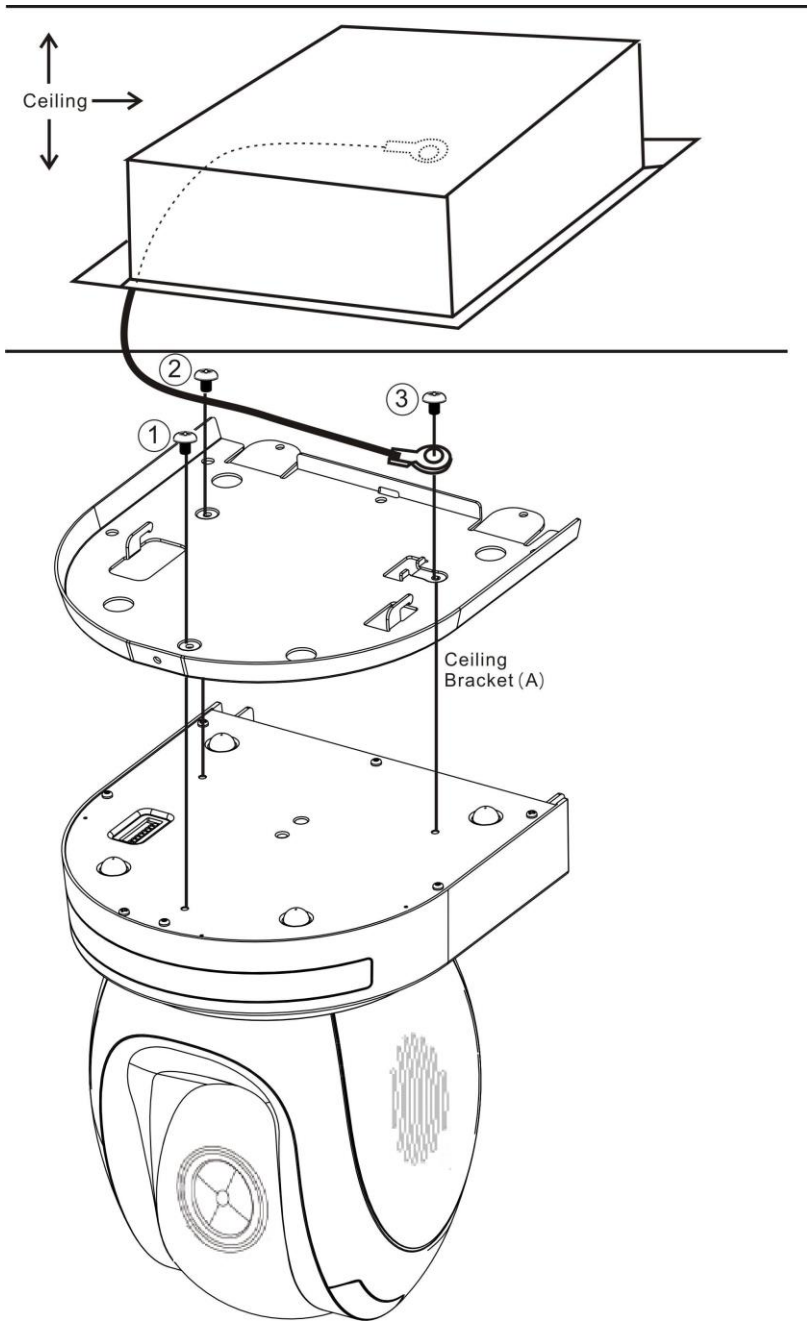

## Step 5 – Mount Camera to Ceiling

---

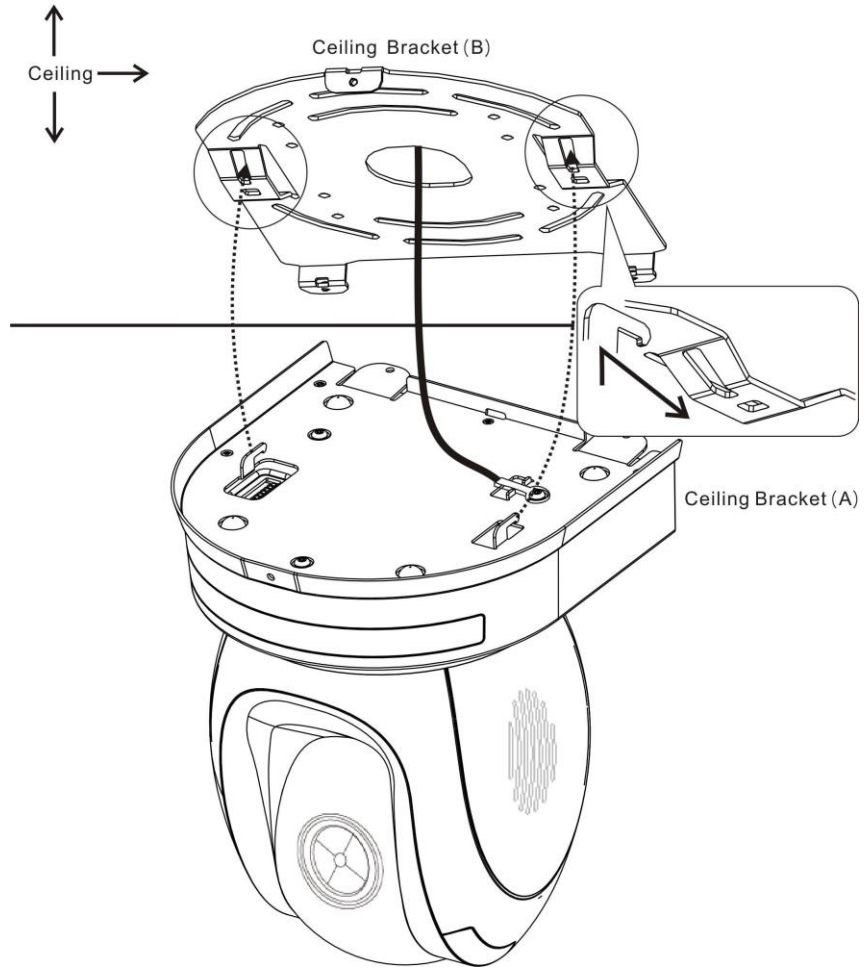

## Step 6 – Screw to Fix Camera

Fix the camera by screwing three screws into the corresponding screw holes as shown in the diagram below.

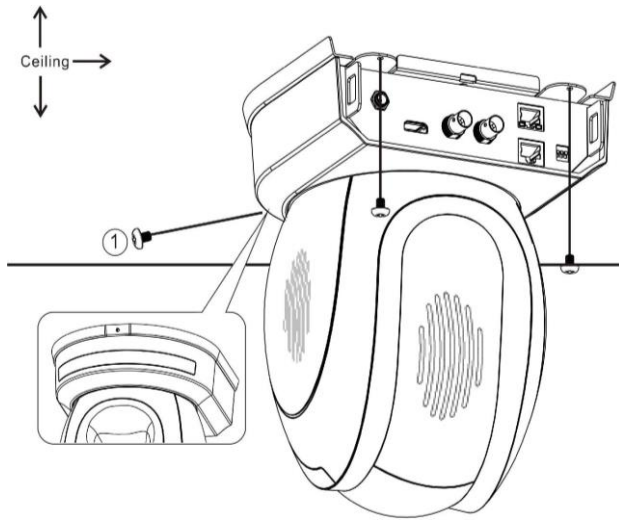

## Step 7 – Cable Connection

Connect the cables to the connectors located on the rear of the camera.

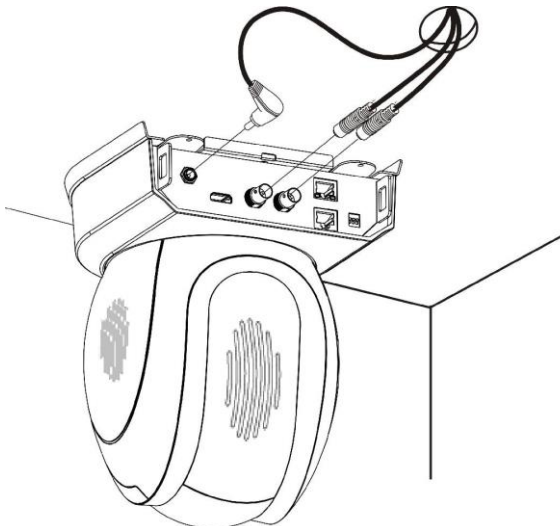

## 7. DIP Switch Settings

### 7.1 DIP Switch SW1

The DIP Switch SW1 can be found at the bottom of the camera, where the user is allowed to set the camera's VISCA ID, enable remote control, select the video resolution, and configure how the video mode can be selected.

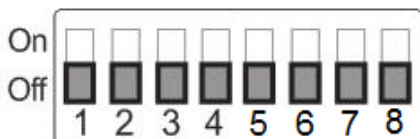

DIP SW 1/2/3	VISCA ID
(1,2,3) = (ON,OFF,OFF)	VISCA-ID 1
(1,2,3) = (OFF,ON ,OFF)	VISCA-ID 2
(1,2,3) = (ON ,ON ,OFF)	VISCA-ID 3
(1,2,3) = (OFF,OFF,ON)	VISCA-ID 4
(1,2,3) = (ON ,OFF,ON)	VISCA-ID 5
(1,2,3) = (OFF,ON ,ON)	VISCA-ID 6
(1,2,3) = (ON ,ON ,ON)	VISCA-ID 7
DIP SW 4	Remote Control Protocol
ON	DVIP
OFF	RS-422
DIP SW 5/6/7	Resolution
(5,6,7) = (OFF,OFF,OFF)	1920x1080i60
(5,6,7) = (ON,OFF,OFF)	1920x1080i50
(5,6,7) = (OFF,ON,OFF)	1280x720p60
(5,6,7) = (ON,ON,OFF)	1280x720p50
(5,6,7) = (OFF,OFF,ON)	1920x1080p29.97
(5,6,7) = (ON,OFF,ON)	1920x1080p25
(5,6,7) = (OFF,ON,ON)	1920x1080p59.94
(5,6,7) = (ON,ON,ON)	1920x1080p50
DIP SW 8	Video Mode Selection Method
ON	Video mode selectable by DIP switch only
OFF	Video mode selectable by menu

## 7.2 DIP Switch SW2 (IRID)

The IRID DIP Switch can be found on the rear panel of the PTC-150/PTC-150W camera. This DIP switch allows the user to assign an ID number to the camera so that the user can navigate between the cameras by pressing the **CAMERA SELECT** buttons.

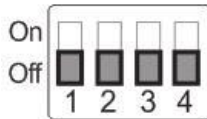

DIP SW 1/2	Camera Select Function (IR Remote Control) – Camera ID Assignment
(1,2) = (OFF,OFF)	CAM1 (IR)
(1,2) = (ON,OFF)	CAM2 (IR)
(1,2) = (OFF,ON)	CAM3 (IR)
(1,2) = (ON,ON)	CAM4 (IR)
* DIP SW 3/4 should be always OFF.	



## 8. Network Configuration

The DVIP Configuration Tool allows the user to configure network settings of the PTC series cameras on the PC. **The DVIP Configuration Tool can be downloaded from the product page.**

**The PTC series cameras usually have a static IP address of 192.168.100.XXX.** The unit can be directly connected to a Windows-based computer using an RJ-45 Ethernet cable. The following setup procedure outlined below should allow you to initially configure the unit before moving it to an existing DHCP / LAN network.

**Note: All devices should be connected to the same network domain.**

1. First connect the **DVIP port** of the **PTC-150/PTC-150W PTZ camera** to a Windows computer using an RJ-45 Ethernet cable.

**Note: You do not need to manually assign an IP address to the PC but make sure the right interface card is selected at Step 11.**

2. Install the DVIP Configuration Tool by double clicking the executable file already downloaded to your computer.
3. Locate the DIP switch at the bottom of the PTC series camera.

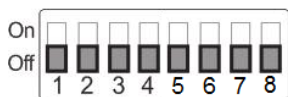
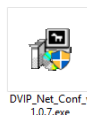

4. Set DIP Switch positions 1 and 4 to ON.



5. Plug in the power cord into the PTC series camera and connect it to a monitor via the HDMI interface.
6. Open the main menu by pressing the menu button on the IR remote control and select option 4 **“Remote Control.”**

[MAIN MENU]

- 1: CAMERA SET (NORMAL)
- 2: MEMORY
- 3: VIDEO OUTPUT
- 4: REMOTE CONTROL

```
5: SYSTEM
6: CAMERA SET (ADVANCE)
7: RESET P/T/Z
8: ESCAPE
```

7. Select **"SET DVIP."**

```
[REMOTE CONTROL]
1: PAN/TILT REVERSE: P+T
2: REMOTE SOURCE: DVIP, SW
3: SET RS422
4: SET DVIP
5: SET IR
6: PTZ INFO. OUTPUT: OFF
7: ESCAPE
```

8. Set **DVIP baud rate** to 115200.

```
[SET DVIP]
1: DVIP BAUDRATE: 115200
2: ESCAPE
```

9. Connect your PC directly to the DVIP port on the PTC series camera or if in a multiple DVIP device environment, connect all devices to an Ethernet router. Please note that the router and the connected devices should be in the same IP range.
10. On the PC, open the DVIP Configuration Tool by double clicking **"DVIP\_Net\_Conf.exe."** **The DVIP Configuration Tool can be obtained from Datavideo local distributors or downloaded from the product page.**
11. After the DVIP Configuration Tool is opened, select your network interface card and click the **"OK"** button.



**Note: Make sure you select the card that is on the same network as the camera or else the DVIP Configuration Tool will not be able to find the connected DVIP devices.**

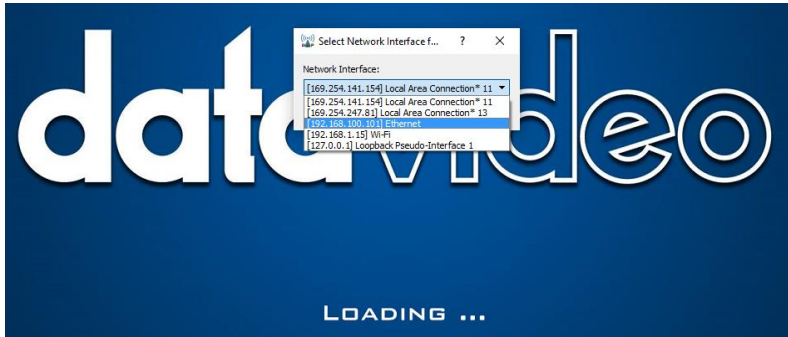

12. On the DVIP Device List, you will then be able to see the Device Name, MAC address and IP address of the connected device.

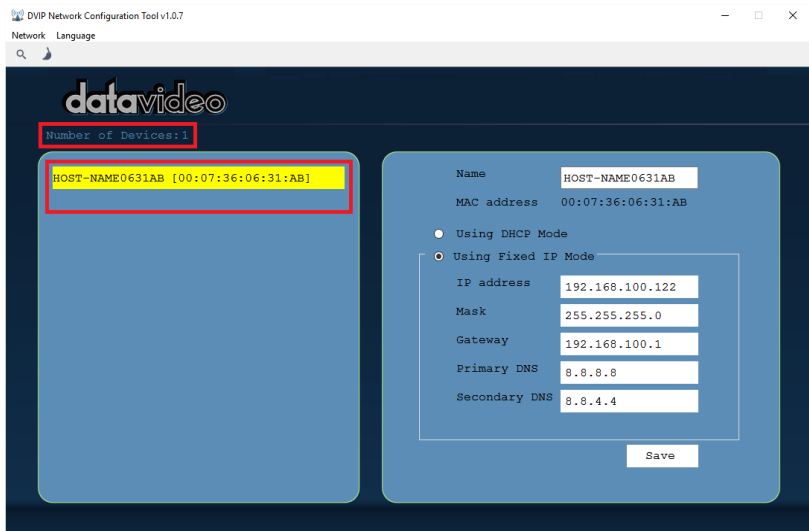

13. After the network setting (Static or DHCP) and the host name are properly configured, click the “**Save**” button to write the new information into the device.
14. Right after the “**Save**” button is clicked, you will be able to see a prompt message at the top right corner to request for a device reboot for the new settings to become effective.

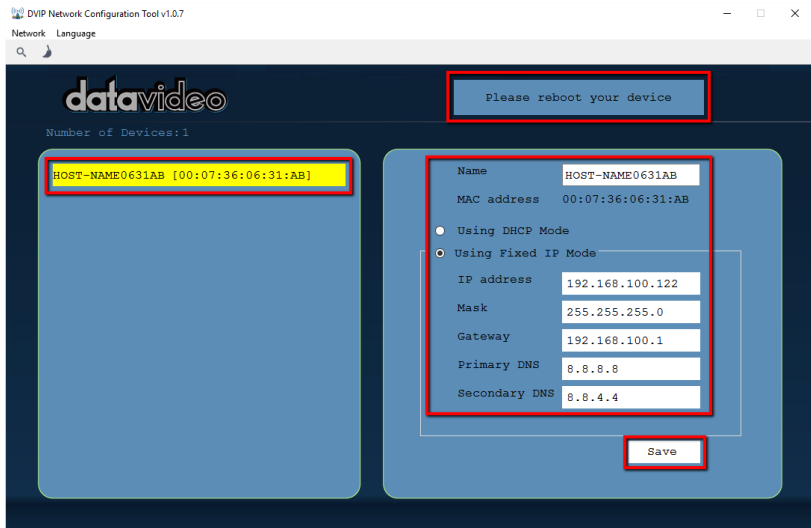

15. Reboot the device to apply the new settings.

In addition to configuring network settings of the connected DVIP devices, the DVIP configuration tool also allows you to **search for DVIP devices**, **clear the device list**, **switch to other interface cards** and **change the interface language**. Each individual function is described below.

- **Device Search**

On the tool bar, the user can click the search icon to search for all DVIP devices.



- **Clearing Device List**

On the tool bar, the user is allowed to clear the device list by clicking the “Device List Clear” button.



- **Switch to Other Network Interfaces**

To select other network interface cards, click Network → Network Card

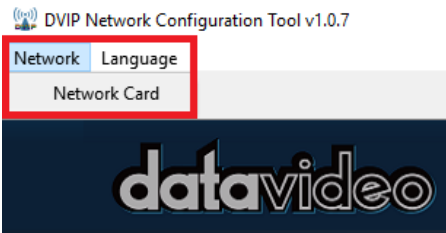

- **Language Selection**

On the tool bar, select a language: **Traditional Chinese, Simplified Chinese** or **English**

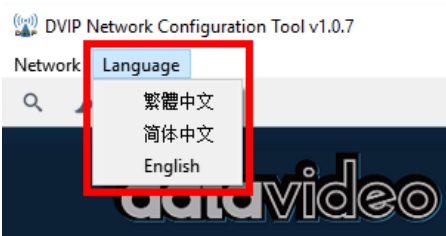

## 9. RMC-180 PTZ Camera Control Unit

The RMC-180 PTZ Camera Controller is designed to control up to 4 Datavideo Pan Tilt Zoom (PTZ) cameras such as the PTC-150/PTC-150W.

The four RJ-45 ports provided on the RMC-180 rear serve to connect PTZ cameras, thus allowing the user to use any RJ-45 cable to connect the RMC-180 to the RS-422 port located on the PTZ camera's rear panel. The communication protocol is VISCA.

**Note: Before connecting the camera to these channel ports, please set bit 4 of the camera DIP switch located at the bottom to OFF.**

### Direct Connection to Camera

To use the RMC-180 PTZ Camera Control Unit to directly control the PTC-150/PTC-150W camera, connect the RS-422 port on the camera's rear panel to the RJ-45 port of the RMC-180 using any RJ-45 cable. The RS-422 wiring scheme is shown below.

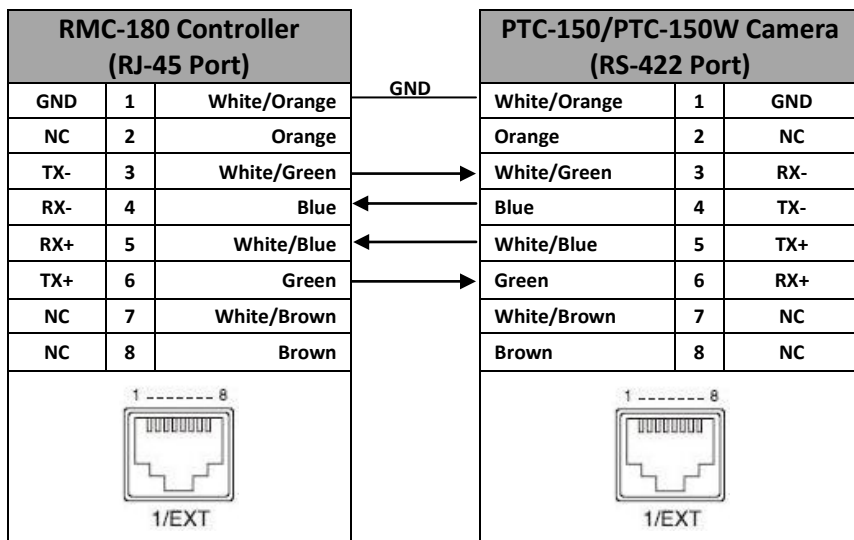

## 10. Firmware Update

- 1) Copy three image files, p150mcpu.bin, P150FPGA.bin and p150mctl.bin, into the root directory of a USB hard drive (<16 GB) and insert it into the USB port of PTC-150/PTC-150W (You may also use USB extension cord).
- 2) Open the operation menu of IR remote controller (select from CAM 1-4; default is CAM1)
- 3) Main Menu  
=> 5: SYSYEM  
    => 4: UPDATE SOFTWARE  
        => 5: UPDATE ALL  
            =>YES  
                => ENTER
- 4) Wait for another five minutes until the following lines appear on the screen
  - Updated Mot-BD=>OK.
  - Updated FPGA =>OK.
  - Updated MCPU =>OKThe OSD will flash "Write OK/Power ON Again" alternately; it takes approximately 5-7 minutes to complete the update.
- 5) Turn off the device by unplugging the power cord and plug the power cord back into the socket to turn on the device again.
- 6) FW Update is complete.

# 11. Frequently-Asked Questions

This section describes problems that you may encounter while using the PTC-150/PTC-150W. If you have any questions, please refer to related sections and follow all suggested solutions. If problem still exists, please contact your distributor or the service center.

No.	Problems	Solutions
2.	<b>The PTC-150/PTC-150W camera does not respond to the command issued from the RMC-180 using the off-the-shelf RS-422-to-RS-232 adapter.</b>	Make sure the off-the-shelf D-Sub 9 pin adapter is specifically designed for the <b>RS-422-to-RS-232</b> conversion purpose. If the adapter can be used for either of RS-422-to-RS-232 and RS-485-to-RS-232, TX pin might be automatically switched to the TX/RX pin, causing the PTC-150/PTC-150W camera to receive incorrect control commands.



# 12. Dimensions

Unit: mm

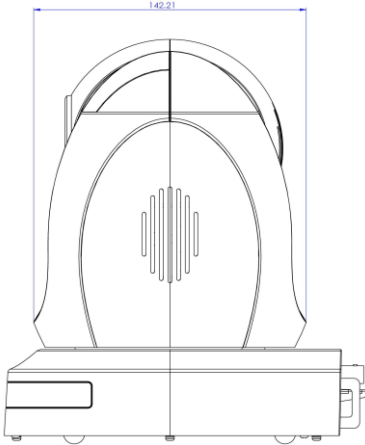
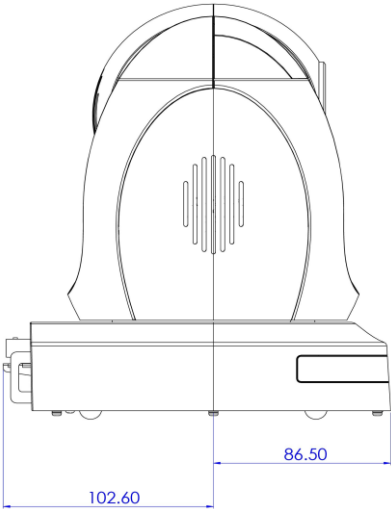
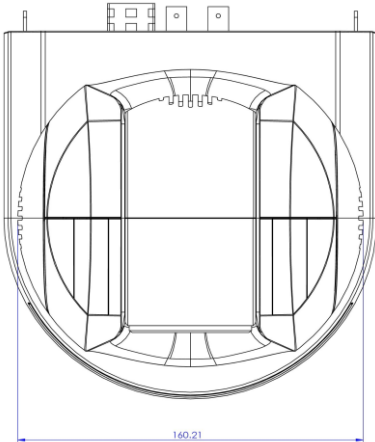

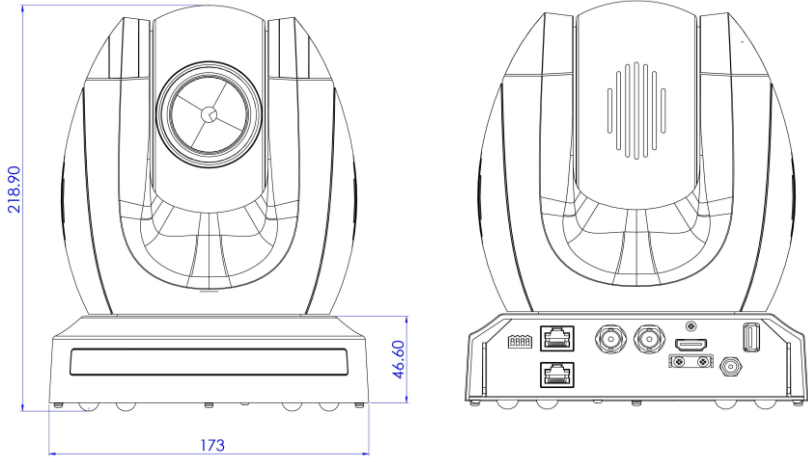

## 13. Specifications

Video	
<b>Image Pickup Element</b>	1/2.8" type progressive scan CMOS sensor
<b>Effective Picture Elements</b>	Approx. 2.14 Mega pixels
<b>Resolution</b>	HD / FHD / SD (CVBS only)
<b>Signal System</b>	HDMI & SDI: 1080p 59.94/50/29.97/25 1080i 59.94/50 720p 59.94/50 CVBS: 480i, 576i
<b>S/N Ratio</b>	50 dB
<b>Min. Illumination</b>	Color : 0.4 lx (F1.6, 1/30 sec, 50IRE, Gain: High) B/W : 0.03 lx (F1.6, 1/30 sec, 50IRE, Gain: High)
<b>Electric Shutter</b>	1/25 (1/30), 1/50 (1/60), 1/120 (1/100), 1/250, 1/500, 1/1000 sec
<b>Gamma Control</b>	Off / Normal / Standard Mode 1-4
<b>Iris Control</b>	Auto / Manual
<b>Digital Noise Reductions</b>	0 - 5
<b>On-Screen Display (OSD)</b>	English
<b>White Balance</b>	AWB / MWB / One push WB / Outdoor / Indoor / Fluorescent
<b>AGC / Gain Control</b>	Auto / Manual (0 to 39 step) Max. Gain Limit (9 to 39 step)
<b>Zoom Ratio</b>	30x Optical Zoom
<b>Mirror</b>	OFF / Horizontal / Vertical / H+V
<b>Camera Title (OSD)</b>	ON / OFF
<b>Color Bar</b>	On / Off (Full Bar)
<b>Focus Mode</b>	Auto / Manual
<b>Day &amp; Night (IR)</b>	Auto / Color / BW
Pan / Tilt / Zoom	
<b>Pan/Tilt Range</b>	Pan: 270° , Tilt: +90° to -20°
<b>Pan/Tilt Speed</b>	Manual: 1~150°/Sec Swing: 1~150°/Sec
<b>Initialization Time</b>	30 sec
<b>Coordinate Report</b>	P, T, Z (While Panning , Tilting and Zooming ) by frame

<b>Lens</b>	
<b>Lens Type</b>	30x Optical Zoom
<b>Focal Length</b>	F=4.3 mm (WIDE) to 129 mm (TELE) F1.6 to F4.7
<b>Angle of View (Horizontal)</b>	Approx. 63.7 degrees (WIDE END) / 2.3 degrees (TELE END)
<b>Filter</b>	M52.0x0.75 Thread with UV Protection
<b>RoHS</b>	Compliant
<b>Video Output</b>	
<b>Video Output</b>	HDMI (V1.3) x 1 HD-SD-SDI x 1 CVBS x 1
<b>Video Format Output</b>	1 Vp-p / 75 Ohms
<b>Control</b>	
<b>Protocol</b>	VISCA / DVIP
<b>Remote Control</b>	RS-422 & DVIP by RJ-45 interface
<b>Remote Controller</b>	RMC-180
<b>F/W Update</b>	USB 2.0
<b>IR Control</b>	One IR controller
<b>Others</b>	
<b>Moving Noise while Tilt</b>	<=25dB
<b>Moving Noise while Pan</b>	<=25dB
<b>Operating Temperature</b>	0°C ~ 50°C
<b>Storage Temperature</b>	- 10°C ~ 60°C
<b>Operating Humidity:</b>	10 % to 80 % (no condensation)
<b>Certifications</b>	CE / FCC Class A
<b>Weight</b>	2.76 Kg (Camera Device Only)
<b>Accessories</b>	IR Remote Controller Mounting Bracket (for table or ceiling) Mounting Bracket (for main unit) Mounting Screws DC 12V Power Adapter Power Cord

# Notes

---

# Notes

---

# Notes

---

## Service & Support

It is our goal to make your products ownership a satisfying experience. Our supporting staff is available to assist you in setting up and operating your system. Please refer to our web site [www.datavideo.com](http://www.datavideo.com) for answers to common questions, support requests or contact your local office below.



Please visit our website for latest manual update.  
<https://www.datavideo.com/product/PTC-150>

**datavideo**  
[www.datavideo.com](http://www.datavideo.com)



@DatavideoUSA @DatavideoIndia2016  
@DatavideoEMEA @Datavideojapan  
@DatavideoTaiwan @DatavideoLatam  
@DatavideoAsia @DatavideoBrasil



@Datavideo  
@Datavideo\_EMEA  
@Datavideo\_Taiwan



@DatavideoUSA  
@DVTWDCVN



@DatavideoUSA  
@DatavideoEurope

All the trademarks are the properties of their respective owners.  
Datavideo Technologies Co., Ltd. All rights reserved 2020