

Step 1. Download the latest GLUE LOCK App. Secure the lock cylinder on the outside of the door with sticky tape. This makes it easier whilst you fit your Glue Smart Lock.

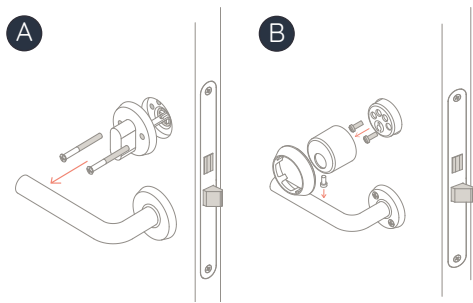

Step 2A. Remove the existing inside thumb turn by unscrewing the two screws in the thumb turn plate. Follow step 3A.

Step 2B. For key cylinder, remove cover and key cylinder. Keep these screws as you will use them later, if they are long enough. Follow step 3C.

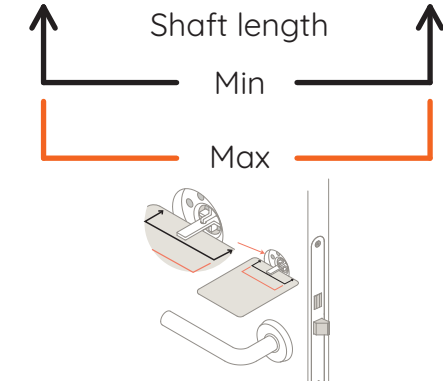

Step 3A. Measure the existing tail piece in your lock with the guide above. The end of the tail piece should not exceed the max line.

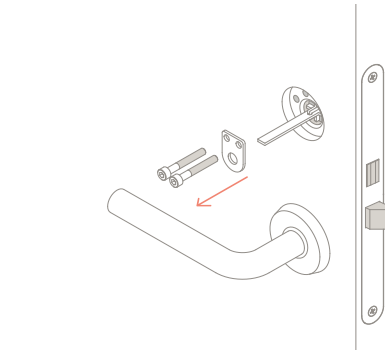

Step 3B. If the tail piece is too short, or too long, unscrew the D-plate and carefully remove it. Be careful not to drop the screws inside the door body.

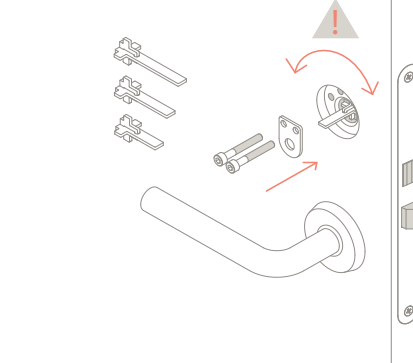

Step 3C . Replace with one of the three tail pieces supplied, choose one that fits between the MIN and MAX lines (step 3A).

DO NOT ROTATE THE LOCK OR TAIL PIECE WHEN FITTING.

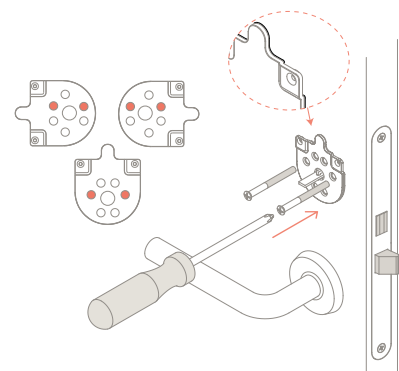

Step 4. Use screws from step 2 to loosely attach the door plate. Use holes shown above depending on the chosen mounting angle. The rubber side of the plate faces the door. If a different length screw is required, cut the longer screws supplied to the correct length.

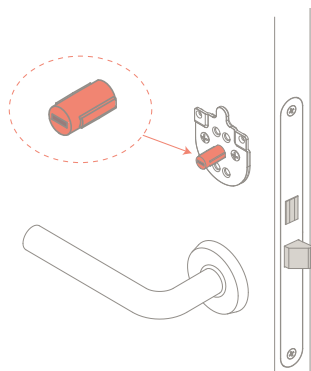

Step 5. Slide the insert supplied over the tail piece.

DO NOT ROTATE THE TAIL PIECE WHEN FITTING.

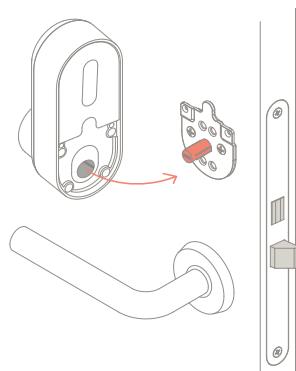

Step 6. Turn the thumb turn on the Glue Smart Lock to the approximate centre, until the slots inside the turning section align with the ribs on the insert. Then slide the Glue Smart Lock over the insert onto the door plate.

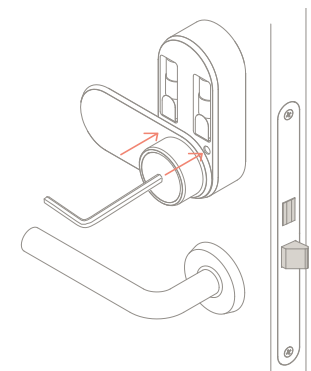

Step 7. Holding the Glue Smart Lock against the door, screw the two screws behind the battery cover to the door plate. Use the thumb turn on the Glue Smart Lock to check the deadbolt opens and closes smoothly, if not, return to Step 4 and check all parts are correctly fitted.

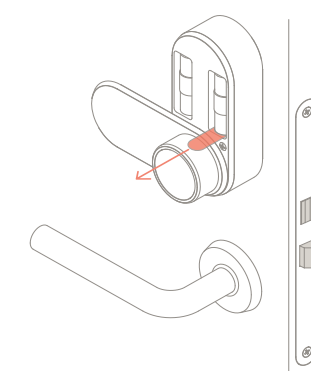

Step 8. Check the lock is securely fastened to the door. If not, check all screws in step 4 and then step 7 are tightened. Then remove the battery tabs. The light behind the thumb turn will flash.

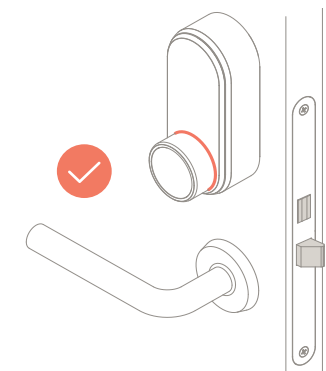

Step 9. Once the light has flashed behind the thumb turn your Glue Smart Lock is ready to calibrate.

From now on follow the instructions in the app "Add new Glue Lock".



INSTALLATION INSTRUCTIONS TERMS AND CONDITIONS

Thank you for purchasing this Glue Smart lock(GL05X.XX)

Handling Guidelines

You should only use your Glue Smart Lock in conjunction with the Glue Wi-Fi Hub if you have one - this ensures that the Glue Smart Lock will perform as designed, with maximum security and functionality. It is your responsibility to ensure that unauthorised persons do not have access to your account with Glue. We strongly recommend all Glue Smart Lock users to use PIN code protection with all mobile devices on which the Glue application is installed. Please retain all instructions, packaging and installation tools. Before using the Device(s), familiarize all users with how the Device(s) and our services work and make sure that all users have read and understand our Terms and Conditions and Privacy Policy available on our website www.gluehome.com

The Device(s) and our services are most effective and will perform as designed, if your home Wi-Fi network is functioning. If your home Wi-Fi network is not functioning, the Glue Smart Lock will function via Bluetooth communication, only when the user's phone is within a range of 3 metres. The Glue Wi-Fi Hub should be placed in a location where it is able to have unimpeded communication with the Glue Smart Lock.

The Glue Wi-Fi Hub should be located no less than 1 metre and no greater than 5 metres from the Glue Smart lock. Utilise your Glue Smart Lock in accordance with recommendations set out for physical key usage by your household insurer. Wipe the Glue Smart Lock with a soft damp cloth to clean. To clean the Glue Wi-Fi Hub, remove from the power socket and wipe body only with a soft DRY cloth.

Battery Handling

Ensure that the battery replacement warnings on the app are adhered to as instructed. Batteries are to be installed as instructed - take care not to put the batteries in to the product in the wrong orientation. The + and - icons on the battery should be orientated in accordance with the + and - icons in the base of the battery housing. When inserting the batteries, it is easiest to insert the negative (-) end first. Only standard Alkaline 1.5V AA batteries should be used with the Glue Smart Lock, rechargeable batteries are not suitable for use. When replacing the batteries, ensure that the ribbon is correctly placed underneath the batteries with the end of the ribbon exposed - to enable you to remove the batteries with ease on the next occasion. If the Glue Smart Lock is to be unused for an extended period of time, please remove the batteries to help protect against battery leakage. To disconnect your Glue Smart Lock, remove all the batteries. To disconnect your Glue Wi-Fi Hub, either switch off at the power socket, or remove from the power socket.

Restrictions of use

The Glue Smart Lock is rated at 6V DC. This Glue Wi Fi Hub is rated at 220 - 230V AC 50/60 Hz only. The Device(s) should be used and stored between the following temperatures -10°C and +40°C. Ensure that the Device(s) are not located in direct sunlight for prolonged periods of the day. The Device(s) should not become wet during use.

Ensure that the Device(s) are not used in excessively dusty environments. The Device(s) must not have been misused, abused, disassembled or modified in any way. Ensure the battery pull ribbon is in the correct position when replacing batteries to enable ease of battery removal in future.

Frequency Range: 2402MHz - 2480MHz

Maximum RF Power output:

Lock BLE = 4 dBm

FW version: 1.14

HW version: V3

Hub

Frequency Range 2400 - 2483.5 MHz

Maximum RF Power Output

Hub BLE = 3.43dBm, Wi-Fi = 18.20dBm

FW Version 31

This Glue Wi-Fi Hub is rated at 220 -230V AC 50/60 Hz only.

The Device(s) should not become wet during use. Ensure that the Device(s) are not used in excessively dusty environments. The Device(s) must not have been misused, abused, disassembled or modified in any way.

Manufacturer - Glue AB, Grev Turegarten 26, SE-114 38 Stockholm, Sweden

Importer - Glue AB, Grev Turegarten 26, SE- 114 38 Stockholm, Sweden

Hereby, Glue AB declares that the radio equipment type Bluetooth Electronic Lock and WiFi to Bluetooth Bridge is in compliance with Directive 2014/53/EU The full text of the EU declaration of conformity is available at the following internet address: <https://www.gluehome.com/legal/compliance>

Return policy

If you are a consumer (i.e. a private individual not acting on behalf of a business) and if you for any reason are not entirely satisfied with your purchase, you are entitled to return the Device(s) within 30 days after receipt of the Device(s). Your notification regarding cancellation must be given to Glue within 30 days after your receipt of the Device(s). Please contact our customer service at support@gluehome.com in order to properly register your notification with Glue. Your message to our customer service must clearly state that you wish to use your right of returning the

Device(s) and contain at least the following information:

- Your order number;
- Confirmation of your payment; and
- Title of the product you wish to return.

As an alternative to the instructions above for your notification with Glue, you are entitled to use a standard form for notification of return provided by the Swedish Consumer Agency (Sw. Konsumentverket) which can be found at the website www.konsumentverket.se (Swedish language version) which is based on Appendix 1 to Directive 2011/83/EC which can be found at http://ec.europa.eu/consumers/consumer_rights/rights-contracts/directive If you wish to cancel your purchase of the Device(s) in accordance with above, you shall, without undue delay and at the latest within 14 days, from the date of your notification regarding cancellation to Glue, return the Device(s). Our customer service will provide you with the address for returning the Device(s). You will have to pay the direct cost of returning the Device(s), including any shipping costs. The cost for returning the Device(s) is estimated at a maximum of approximately EURO 20 for shipping within the EU. Please note that this amount is an estimate of the maximum costs and that the costs may deviate depending on the place from where the Device(s) is sent. Glue will process any refund to you without undue delay and within 14 days from the day on which you gave Glue notice of return in accordance with above, provided, however, that we, within this time period have received either (i) the Device(s) in return, or (ii) you have submitted evidence that you have returned the Device(s) in accordance with our instructions. Glue has a right to withhold the refund until either of (i) or (ii) occurs, whichever occurs first. Glue will refund the money received from you using the same method originally used by you to pay for the Device(s), unless you have expressly agreed with us otherwise. Glue will refund all payments that we have received from you in relation to your purchase of the Device(s) in full, including the original delivery charges if paid by you (but not including additional delivery charges as a result of you choosing a delivery other than our standard delivery). However, you are responsible for any decrease in value of the returned Device(s) to the extent the returned Device(s) has been handled more extensively than necessary in order for you to determine its features or function. Glue is entitled to make deductions from the refund for such diminished value of the Device(s).

Faulty Device(s)

It is important that you check your Device(s) upon receipt in order to verify that the Device(s) is correct and free from manufacturing defects. If your Device(s) is incorrect or faulty, please report this as soon as possible to our customer service at support@gluehome.com Please note that faulty Device(s) as a result of wear and tear is not considered to be faulty. You have a right to return Device(s) with manufacturing defects which exists when the Device(s) is delivered to you and which arises within a period of 24 months from the date of delivery, provided that your complaint is made with Glue within a reasonable time after the circumstances leading to the complaint was discovered or should have been discovered. A complaint made within two (2) months after the manufacturing defect was discovered, within the said 24 months period, shall always be deemed to have been made within reasonable time. If we are not able to replace or remedy the faulty Device(s) within reasonable time, we will refund the amount you have paid for the faulty Device(s) together with return shipping charges.

Privacy Policy

Please read these instructions, our Terms and Conditions and our Privacy Policy carefully and make sure that you understand them, before you start using the Device(s). Our Terms and Conditions and Privacy Policy can be found at our website, www.gluehome.com. By downloading the Glue application and registering an account with Glue you acknowledge that you have read, agreed to and accept the Terms and Conditions and Privacy Policy and commits to adhere to them. Please note that Glue may update the Terms and Conditions and Privacy Policy from time to time, in accordance with the Terms and Conditions and Privacy Policy.

Battery Replacement

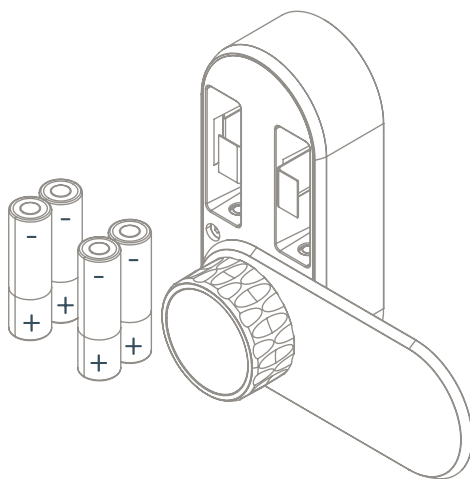

To replace the batteries rotate the front cover of the product and pull the fabric tabs to release your existing AA batteries.

When inserting your new batteries ensure that the batteries are orientated with the positive terminal closest to the thumb turn.

The answers for our most common questions are published in the support section of the Glue website.

www.gluehome.com/support