

OPEN Industry Standard, Flexible Architecture

GREEN Less Heat, Less Power Consumption

STABLE Robust Design, Quality Parts

Stable and
Reliable Solution

Server/Workstation

Motherboard

Z690D4U/G5

Z690D4U-2L2T/G5

W680D4U-2L2T/G5

Z690D4U-2L2T/G5/BCM

W680D4U-2L2T/G5/BCM

User Manual

English



Version 1.03

Published Nov. 2024

Copyright©2024 ASRock Rack INC. All rights reserved.

Copyright Notice:

No part of this documentation may be reproduced, transcribed, transmitted, or translated in any language, in any form or by any means, except duplication of documentation by the purchaser for backup purpose, without written consent of ASRock Rack Inc.

Products and corporate names appearing in this documentation may or may not be registered trademarks or copyrights of their respective companies, and are used only for identification or explanation and to the owners' benefit, without intent to infringe.

Disclaimer:

Specifications and information contained in this documentation are furnished for informational use only and subject to change without notice, and should not be construed as a commitment by ASRock Rack. ASRock Rack assumes no responsibility for any errors or omissions that may appear in this documentation.

With respect to the contents of this documentation, ASRock Rack does not provide warranty of any kind, either expressed or implied, including but not limited to the implied warranties or conditions of merchantability or fitness for a particular purpose.

In no event shall ASRock Rack, its directors, officers, employees, or agents be liable for any indirect, special, incidental, or consequential damages (including damages for loss of profits, loss of business, loss of data, interruption of business and the like), even if ASRock Rack has been advised of the possibility of such damages arising from any defect or error in the documentation or product.



This device complies with Part 15 of the FCC Rules. Operation is subject to the following two conditions:

- (1) this device may not cause harmful interference, and
- (2) this device must accept any interference received, including interference that may cause undesired operation.

This equipment has been tested and found to comply with the limits for a Class B digital device, pursuant to part 15 of the FCC Rules. These limits are designed to provide reasonable protection against harmful interference in a residential installation. This equipment generates, uses and can radiate radio frequency energy and, if not installed and used in accordance with the instructions, may cause harmful interference to radio communications.

However, there is no guarantee that interference will not occur in a particular installation. If this equipment does cause harmful interference to radio or television reception, which can be determined by turning the equipment off and on, the user is encouraged to try to correct the interference by one or more of the following measures:

- Reorient or relocate the receiving antenna.
- Increase the separation between the equipment and receiver.
- Connect the equipment into an outlet on a circuit different from that to which the receiver is connected.
- Consult the dealer or an experienced radio/TV technician for help.

INTEL END USER SOFTWARE LICENSE AGREEMENT
IMPORTANT - READ BEFORE COPYING, INSTALLING OR USING.

LICENSE. Licensee has a license under Intel's copyrights to reproduce Intel's Software only in its unmodified and binary form, (with the accompanying documentation, the "Software") for Licensee's personal use only, and not commercial use, in connection with Intel-based products for which the Software has been provided, subject to the following conditions:

- (a) Licensee may not disclose, distribute or transfer any part of the Software, and You agree to prevent unauthorized copying of the Software.
- (b) Licensee may not reverse engineer, decompile, or disassemble the Software.
- (c) Licensee may not sublicense the Software.
- (d) The Software may contain the software and other intellectual property of third party suppliers, some of which may be identified in, and licensed in accordance with, an enclosed license.txt file or other text or file.
- (e) Intel has no obligation to provide any support, technical assistance or updates for the Software.

OWNERSHIP OF SOFTWARE AND COPYRIGHTS. Title to all copies of the Software remains with Intel or its licensors or suppliers. The Software is copyrighted and protected by the laws of the United States and other countries, and international treaty provisions. Licensee may not remove any copyright notices from the Software. Except as otherwise expressly provided above, Intel grants no express or implied right under Intel patents, copyrights, trademarks, or other intellectual property rights. Transfer of the license terminates Licensee's right to use the Software.

DISCLAIMER OF WARRANTY. The Software is provided "AS IS" without warranty of any kind, EITHER EXPRESS OR IMPLIED, INCLUDING WITHOUT LIMITATION, WARRANTIES OF MERCHANTABILITY OR FITNESS FOR ANY PARTICULAR PURPOSE.

LIMITATION OF LIABILITY. NEITHER INTEL NOR ITS LICENSORS OR SUPPLIERS WILL BE LIABLE FOR ANY LOSS OF PROFITS, LOSS OF USE, INTERRUPTION OF BUSINESS, OR INDIRECT, SPECIAL, INCIDENTAL, OR CONSEQUENTIAL DAMAGES OF ANY KIND WHETHER UNDER THIS AGREEMENT OR OTHERWISE, EVEN IF INTEL HAS BEEN ADVISED OF THE POSSIBILITY OF SUCH DAMAGES.

LICENSE TO USE COMMENTS AND SUGGESTIONS. This Agreement does NOT obligate Licensee to provide Intel with comments or suggestions regarding the Software. However, if Licensee provides Intel with comments or suggestions for the modification, correction, improvement or enhancement of (a) the Software or (b) Intel products or processes that work with the Software, Licensee grants to Intel a non-exclusive, worldwide, perpetual, irrevocable, transferable, royalty-free license, with the right to sublicense, under

Licensee's intellectual property rights, to incorporate or otherwise utilize those comments and suggestions.

TERMINATION OF THIS LICENSE. Intel or the sublicensor may terminate this license at any time if Licensee is in breach of any of its terms or conditions. Upon termination, Licensee will immediately destroy or return to Intel all copies of the Software.

THIRD PARTY BENEFICIARY. Intel is an intended beneficiary of the End User License Agreement and has the right to enforce all of its terms.

U.S. GOVERNMENT RESTRICTED RIGHTS. The Software is a commercial item (as defined in 48 C.F.R. 2.101) consisting of commercial computer software and commercial computer software documentation (as those terms are used in 48 C.F.R. 12.212), consistent with 48 C.F.R. 12.212 and 48 C.F.R. 227.7202-1 through 227.7202-4. You will not provide the Software to the U.S. Government. Contractor or Manufacturer is Intel Corporation, 2200 Mission College Blvd., Santa Clara, CA 95054.

EXPORT LAWS. Licensee agrees that neither Licensee nor Licensee's subsidiaries will export/re-export the Software, directly or indirectly, to any country for which the U.S. Department of Commerce or any other agency or department of the U.S. Government or the foreign government from where it is shipping requires an export license, or other governmental approval, without first obtaining any such required license or approval. In the event the Software is exported from the U.S.A. or re-exported from a foreign destination by Licensee, Licensee will ensure that the distribution and export/re-export or import of the Software complies with all laws, regulations, orders, or other restrictions of the U.S. Export Administration Regulations and the appropriate foreign government.

APPLICABLE LAWS. This Agreement and any dispute arising out of or relating to it will be governed by the laws of the U.S.A. and Delaware, without regard to conflict of laws principles. The Parties to this Agreement exclude the application of the United Nations Convention on Contracts for the International Sale of Goods (1980). The state and federal courts sitting in Delaware, U.S.A. will have exclusive jurisdiction over any dispute arising out of or relating to this Agreement. The Parties consent to personal jurisdiction and venue in those courts. A Party that obtains a judgment against the other Party in the courts identified in this section may enforce that judgment in any court that has jurisdiction over the Parties.

Licensee's specific rights may vary from country to country.

The terms HDMI® and HDMI High-Definition Multimedia Interface, and the HDMI logo are trademarks or registered trademarks of HDMI Licensing LLC in the United States and other countries.



CALIFORNIA, USA ONLY

The Lithium battery adopted on this motherboard contains Perchlorate, a toxic substance controlled in Perchlorate Best Management Practices (BMP) regulations passed by the California Legislature. When you discard the Lithium battery in California, USA, please follow the related regulations in advance.

“Perchlorate Material-special handling may apply, see www.dtsc.ca.gov/hazardouswaste/perchlorate”

AUSTRALIA ONLY

Our goods come with guarantees that cannot be excluded under the Australian Consumer Law. You are entitled to a replacement or refund for a major failure and compensation for any other reasonably foreseeable loss or damage caused by our goods. You are also entitled to have the goods repaired or replaced if the goods fail to be of acceptable quality and the failure does not amount to a major failure. If you require assistance please call ASRock Rack Tel : +886-2-55599600 ext.123 (Standard International call charges apply)



ASRock Rack INC. hereby declares that this device is in compliance with the essential requirements and other relevant provisions of related UKCA Directives. Full text of UKCA declaration of conformity is available at: <http://www.asrockrack.com>



ASRock Rack INC. hereby declares that this device is in compliance with the essential requirements and other relevant provisions of related Directives. Full text of EU declaration of conformity is available at: <http://www.asrockrack.com>

ASRock Rack follows the green design concept to design and manufacture our products, and makes sure that each stage of the product life cycle of ASRock Rack product is in line with global environmental regulations. In addition, ASRock Rack disclose the relevant information based on regulation requirements.

Please refer to <https://www.asrockrack.com/general/about.asp?cat=Responsibility> for information disclosure based on regulation requirements ASRock Rack is complied with:



DO NOT throw the motherboard in municipal waste. This product has been designed to enable proper reuse of parts and recycling. This symbol of the crossed out wheeled bin indicates that the product (electrical and electronic equipment) should not be placed in municipal waste. Check local regulations for disposal of electronic products.

Contents

Chapter 1 Introduction	1
1.1 Package Contents	1
1.2 Specifications	2
1.3 Unique Features	9
1.4 Motherboard Layout	10
1.5 Onboard LED Indicators	16
1.6 I/O Panel	18
1.7 Block Diagram	21
Chapter 2 Installation	23
2.1 Screw Holes	23
2.2 Pre-installation Precautions	23
2.3 Installing the CPU	24
2.4 Installing the CPU Fan and Heatsink	26
2.5 Installing Memory Modules (DIMM)	27
2.6 Expansion Slots (PCI Express Slots)	29
2.7 Jumper Setup	30
2.8 Onboard Headers and Connectors	31
2.9 Dr. Debug	37
2.10 Unit Identification purpose LED/Switch	43
2.11 Dual LAN and Teaming Operation Guide	44
2.12 M.2 SSD Module Installation Guide (M2_1)	45
Chapter 3 UEFI Setup Utility	47
3.1 Introduction	47

3.1.1	UEFI Menu Bar	47
3.1.2	Navigation Keys	48
3.2	Main Screen	49
3.3	OC Tweaker	50
3.3.1	CPU Configuration	51
3.3.2	DRAM Configuration	56
3.3.3	Voltage Configuration	67
3.4	Advanced Screen	72
3.4.1	CPU Configuration	73
3.4.2	Storage Configuration	76
3.4.3	PCH-FW Configuration	79
3.4.4	Storage Configuration	80
3.4.5	NVME Configuration	81
3.4.6	ACPI Configuration	82
3.4.7	USB Configuration	83
3.4.8	Super IO Configuration	84
3.4.9	Serial Port Console Redirection	85
3.4.10	H/W Monitor	89
3.4.11	Trusted Computing	90
3.4.12	Intel ME Configuration	92
3.4.13	Network Stack Configuration	93
3.4.14	VMD Configuration	94
3.4.15	Driver Health	95
3.4.16	Instant Flash	96

3.5	Security Screen	97
3.5.1	Key Management	98
3.6	Boot Screen	99
3.7	Server Mgmt	101
3.7.1	System Event Log	102
3.7.2	BMC Network Configuration	103
3.7.3	BMC Tools	105
3.8	Event Logs	106
3.9	Exit Screen	108
Chapter 4 Software Support		109
4.1	Download and Install Operating System	109
4.2	Download and Install Software Drivers	109
4.3	Contact Information	109
Chapter 5 Troubleshooting		110
5.1	Troubleshooting Procedures	110
5.2	Technical Support Procedures	112
5.3	Returning Merchandise for Service	112

Chapter 1 Introduction

Thank you for purchasing ASRock Rack **Z690D4U-2L2T/G5 / W680D4U-2L2T/G5 / Z690D4U/G5 / Z690D4U-2L2T/G5/BCM / W680D4U-2L2T/G5/BCM** motherboard, a reliable motherboard produced under ASRock Rack's consistently stringent quality control. It delivers excellent performance with robust design conforming to ASRock Rack's commitment to quality and endurance.

In this manual, chapter 1 and 2 contains introduction of the motherboard and step-by-step guide to the hardware installation. Chapter 3 and 4 contains the configuration guide to BIOS setup and information of the Software Support.



Because the motherboard specifications and the BIOS software might be updated, the content of this manual will be subject to change without notice. In case any modifications of this manual occur, the updated version will be available on ASRock Rack website without further notice. You may find the latest memory and CPU support lists on ASRock Rack website as well. ASRock Rack's Website: www.ASRockRack.com

*If you require technical support related to this motherboard, please visit our website for specific information about the model you are using.
<http://www.asrockrack.com/support/>*

1.1 Package Contents

- ASRock Rack Z690D4U/G5 / Z690D4U-2L2T/G5 / W680D4U-2L2T/G5 / Z690D4U-2L2T/G5/BCM / W680D4U-2L2T/G5/BCM motherboard (mATX form factor: 9.6-in x 9.6-in, 24.4 cm x24.4 cm)
- Quick installation guide
- 1 x SATA3 cable (60cm)
- 1 x I/O shield
- 1 x screw for M.2 socket



If any items are missing or appear damaged, contact your authorized dealer.

1.2 Specifications

Z690D4U-2L2T/G5 / W680D4U-2L2T/G5 / Z690D4U-2L2T/G5/BCM / W680D4U-2L2T/G5/BCM	
MB Physical Status	
Form Factor	Micro-ATX
Dimension	9.6" x 9.6" (244 mm x 244 mm)
Processor System	
CPU	<p>Z690D4U-2L2T/G5 / Z690D4U-2L2T/G5/BCM: - Supports Intel® Core™ 14th Gen, 13th & 12th Gen Intel® Core™, Pentium® and Celeron® series processors</p> <p>W680D4U-2L2T/G5 / W680D4U-2L2T/G5/BCM: - Supports Intel® Core™ 14th Gen, 13th & 12th Gen Intel® Core™ series processors</p>
Socket	Single Socket LGA 1700
Thermal Design Power (TDP)	125W
Chipset	<p>Z690D4U-2L2T/G5 / Z690D4U-2L2T/G5/BCM: - Intel® Z690</p> <p>W680D4U-2L2T/G5 / W680D4U-2L2T/G5/BCM: - Intel® W680</p>
System Memory	
Supported DIMM Quantity	4 DIMM slots (2DPC)
Supported Type	<p>Z690D4U-2L2T/G5 / Z690D4U-2L2T/G5/BCM: - Supports DDR5 288-pin non-ECC UDIMM</p> <p>W680D4U-2L2T/G5 / W680D4U-2L2T/G5/BCM: - Supports DDR5 288-pin ECC/non-ECC UDIMM</p>
Max. Capacity per DIMM	<p>48GB on Intel® Core™ 14th Gen, 13th Gen Intel® Core™ processors</p> <p>32GB on 12th Gen Intel® Core™ processors</p>
Max. Frequency	4400MT/s (2DPC-1DIMM) / 4000MT/s (2DPC-2DIMM 1R) / 3600MT/s (2DPC-2DIMM 2R)
Voltage	1.1V
Note	memory support is to be validated
PCIe Expansion Slots (SLOT7 close to CPU)	
SLOT7	PCIe4.0 x4* [CPU]
SLOT6	PCIe5.0 x16 [CPU]
SLOT4	PCIe3.0 x1 [PCH]
Note	*SLOT7 share lanes with OCuLink4. OCuLink4 will disable when SLOT7 is populated
Other PCIe Expansion Connectors	
M.2 slot	1 M-key (PCIe3.0x4) [PCH]; support 2280/2260/2242/2230 form factor

OCuLink	1 OcuLink (PCIe4.0 x4)* [CPU] 1 OcuLink (PCIe4.0 x4 or 4 SATA 6Gb/s) [PCH] 1 OcuLink (PCIe4.0 x4) [PCH] 1 OcuLink (PCIe3.0 x4) [PCH]
Note	*SLOT7 share lanes with OcuLink4. OcuLink4 will disable when SLOT7 is populated
SATA/SAS Storage	
PCH Built-in Storage	Intel® Z690 (8 SATA 6Gb/s; RAID 0/1/5/10): 4 SATA 7-pin, 1 OcuLink Intel® W680 (8 SATA 6Gb/s; RAID 0/1/5/10): 4 SATA 7-pin, 1 OcuLink
Ethernet	
Additional Ethernet Controller	Z690D4U-2L2T/G5 / W680D4U-2L2T/G5: 2 RJ45 (10GbE) by Intel® X710 2 RJ45 (1GbE) by Intel® i210 Z690D4U-2L2T/G5/BCM / W680D4U-2L2T/G5/BCM: 2 RJ45 (10GbE) by Broadcom BCM57416 2 RJ45 (1GbE) by Intel® i210
USB	
Controller/Hub	Intel® Z690 / Intel® W680
Connectors/headers	External: 2 Type-A (USB3.2 Gen1) Internal: 1 header (19-pin, 2 USB3.2 Gen1) 1 header (9-pin, 2 USB2.0)
Graphics	
Controller	ASPEED AST2600: 1 DB15 (VGA) Intel® Integrated Processor Graphics: 1 HDMI, 1 DisplayPort
Security	
TPM	1 (13-pin, SPI)
Rear I/O	
UID button/LED	1 UID button w/ LED
Video output	1 DB15 (VGA), 1 HDMI, 1 DisplayPort
Serial port	1 DB9 (COM)
USB	2 Type A (USB3.2 Gen1)
RJ45	2 RJ45(10GbE), 2 RJ45(1GbE), 1 dedicated IPMI
Hardware Monitor	
Temperature	CPU, MB, Card side, VR, M.2, X710, TR1 Temperature sensing

Fan	Fan Tachometer CPU Quiet Fan (Allow Chassis Fan Speed Auto-Adjust by CPU Temperature) Fan Multi-Speed Control
Voltage	3VSB, 5VSB, CPU_VCORE, VCCIN_AUX,VDD2, 1.05V_PCH, 0V82SB_PCH, VCCGT, 1V8SB, VCCSA, BAT, 3V, 5V, 12V
Server Management	
BMC Controller	ASPEED AST2600: iKVM, vMedia support
IPMI Dedicated GLAN	1 RJ45 Dedicated IPMI LAN port by Realtek RTL8211F
System BIOS	
BIOS type	AMI 256Mb SPI Flash ROM
Features	Plug and Play, ACPI 6.4 and above compliance wake up events, SMBIOS 3.6.0 and above, ASRock Rack Instant Flash
Internal Connectors/Headers	
PSU connector	1 (24-pin, ATX main power), 2 (8-pin, ATX 12V)
Auxiliary panel header	1 (18-pin): chassis intrusion, system fault LED, LAN1/LAN2 activity LED, locate, SMBus
System panel header	1 (9-pin): power switch, reset switch, system power LED, HDD activity LED
NMI button	1
VGA header	1
Speaker header	1 (4-pin)
Buzzer	1
Fan header	7 (4-pin)
Thermal sensor header	1
TPM header	1 (13-pin, SPI)
SGPIO header	1
SMBus header	1
PMBus header	1
IPMB header	1
Clear CMOS	1 (contact pads)
LED Indicators	
Standby Power LED	1 (5VSB)
80 debug port LED	1
Fan Fail LED	7
BMC Heartbeat LED	1

Supported OS	
OS	<p>Microsoft® Windows®</p> <ul style="list-style-type: none"> - Windows 10 (64 bit) - Windows 11 (64 bit) <p>Linux®</p> <ul style="list-style-type: none"> - RedHat Enterprise Linux Server 8.5 (64bit) / 7.9 (64bit) - CentOS 8.5 (64 bit) / 7.9 (64bit) - SUSE SLES 15.2 (64 bit) / 12.5 (64bit) - Ubuntu 21.10 (64 bit) / 21.04 (64 bit) / 20.04.4 (64 bit) <p>Hypervisor:</p> <ul style="list-style-type: none"> - VMWare® ESXi 7.0 U3d - VMWare® ESXi 6.7.0 U3 <p>* Supports UEFI BOOT only. * The Linux system doesn't support Raid Mode</p>
Environment	
Operating temperature	10 - 35°C (50 - 95 degF)
Non-operating temperature	-40 - 70°C (-40 - 158degF)

NOTE: Please refer to the website for the latest specifications.



This motherboard supports Wake from on Board LAN. To use this function, please make sure that the "Wake on Magic Packet from power off state" is enabled in Device Manager > Intel® Ethernet Connection > Power Management. And the "PCI Devices Power On" is enabled in UEFI SETUP UTILITY > Advanced > ACPI Configuration. After that, onboard LAN1&2 can wake up S5 under OS.



If you install Intel® LAN utility or Marvell SATA utility, this motherboard may fail Windows® Hardware Quality Lab (WHQL) certification tests. If you install the drivers only, it will pass the WHQL tests.

Z690D4U/G5**MB Physical Status**

Form Factor	Micro-ATX
Dimension	9.6" x 9.6" (244 mm x 244 mm)

Processor System

CPU	Supports Intel® Core™ 14th Gen, 13th & 12th Gen Intel® Core™, Pentium® and Celeron® series processors
Socket	Single Socket LGA 1700
Thermal Design Power (TDP)	125W
Chipset	Intel® Z690

System Memory

Supported DIMM Quantity	4 DIMM slots (2DPC)
Supported Type	Supports DDR5 288-pin non-ECC UDIMM
Max. Capacity per DIMM	48GB on Intel® Core™ 14th Gen, 13th Gen Intel® Core™ processors 32GB on 12th Gen Intel® Core™ processors
Max. Frequency	4400MT/s (2DPC-1DIMM) / 4000MT/s (2DPC-2DIMM 1R) / 3600MT/s (2DPC-2DIMM 2R)
Voltage	1.1V
Note	<i>memory support is to be validated</i>

PCIe Expansion Slots (SLOT7 close to CPU)

SLOT7	PCIe4.0 x4* [CPU]
SLOT6	PCIe5.0 x16 [CPU]
SLOT4	PCIe3.0 x1 [PCH]
Note	<i>*SLOT7 share lanes with OCuLink4. OCuLink4 will disable when SLOT7 is populated</i>

Other PCIe Expansion Connectors

M.2 slot	'1 M-key (PCIe3.0 x4); support 2280/2260/2242/2230 form factor [PCH]
OCuLink	1 OCuLink (PCIe4.0 x4)* [CPU] 1 OCuLink (PCIe4.0 x4 or 4 SATA 6Gb/s) [PCH] 2 OCuLink (PCIe4.0 x4) [PCH]
Note	<i>*SLOT7 share lanes with OCuLink4. OCuLink4 will disable when SLOT7 is populated</i>

SATA/SAS Storage

PCH Built-in Storage	Intel® Z690 (8 SATA 6Gb/s; RAID 0/1/5/10): 4 SATA 7-pin, 1 OCuLink
----------------------	---

Ethernet

Additional Ethernet Controller	2 RJ45 (1GbE) by Intel® i210
--------------------------------	------------------------------

USB	
Controller/Hub	Intel® Z690
Connectors/ headers	External: 2 Type-A (USB3.2 Gen1) Internal: 1 header (19-pin, 2 USB3.2 Gen1) 1 header (9-pin, 2 USB2.0)
Graphics	
Controller	ASPEED AST2600: 1 DB15 (VGA) Intel® Integrated Processor Graphics: 1 HDMI, 1 DisplayPort
Security	
TPM	1 (13-pin, SPI)
Rear I/O	
UID button/ LED	1 UID button w/ LED
Video output	1 DB15 (VGA), 1 HDMI, 1 DisplayPort
Serial port	1 DB9 (COM)
USB	2 Type A (USB3.2 Gen1)
RJ45	2 RJ45(1GbE), 1 dedicated IPMI
Hardware Monitor	
Temperature	CPU, MB, Card side, VR, M.2, TR1 Temperature sensing
Fan	Fan Tachometer CPU Quiet Fan (Allow Chassis Fan Speed Auto-Adjust by CPU Temperature) Fan Multi-Speed Control
Voltage	3VSB, 5VSB, CPU_VCORE, VCCIN_AUX,VDD2, 1.05V_PCH, 0V82SB_PCH, VCCGT, 1V8SB, VCCSA, BAT, 3V, 5V, 12V
Server Management	
BMC Controller	ASPEED AST2600: iKVM, vMedia support
IPMI Dedicated GLAN	1 RJ45 Dedicated IPMI LAN port by Realtek RTL8211F
System BIOS	
BIOS type	AMI 256Mb SPI Flash ROM
Features	Plug and Play, ACPI 6.4 and above compliance wake up events, SMBIOS 3.6.0 and above, ASRock Rack Instant Flash

Internal Connectors/Headers	
PSU connector	1 (24-pin, ATX main power), 2 (8-pin, ATX 12V)
Auxiliary panel header	1 (18-pin): chassis intrusion, system fault LED, LAN1/LAN2 activity LED, locate, SMBus
System panel header	1 (9-pin): power switch, reset switch, system power LED, HDD activity LED
NMI button	1
VGA header	1
Speaker header	1 (4-pin)
Buzzer	1
Fan header	7 (4-pin)
Thermal sensor header	1
TPM header	1 (13-pin, SPI)
SGPIO header	1
SMBus header	1
PMbus header	1
IPMB header	1
Clear CMOS	1 (contact pads)
LED Indicators	
Standby Power LED	1 (5VSB)
80 debug port LED	1
Fan Fail LED	7
BMC Heartbeat LED	1
Supported OS	
OS	<p>Microsoft® Windows®</p> <ul style="list-style-type: none"> - Windows 10 (64 bit) - Windows 11 (64 bit) <p>Linux®</p> <ul style="list-style-type: none"> - RedHat Enterprise Linux Server 8.5 (64bit) / 7.9 (64bit) - CentOS 8.5 (64 bit) / 7.9 (64bit) - SUSE SLES 15.2 (64 bit) / 12.5 (64bit) - Ubuntu 21.10 (64 bit) / 21.04 (64 bit) / 20.04.4 (64 bit) <p>Hypervisor:</p> <ul style="list-style-type: none"> - VMWare® ESXi 7.0 U3d - VMWare® ESXi 6.7.0 U3 <p>* Supports UEFI BOOT only. * The Linux system doesn't support Raid Mode</p>

Environment	
Operating temperature	10 - 35°C (50 - 95 degF)
Non-operating temperature	-40 - 70°C (-40 - 158degF)

NOTE: Please refer to the website for the latest specifications.



This motherboard supports Wake from on Board LAN. To use this function, please make sure that the "Wake on Magic Packet from power off state" is enabled in Device Manager > Intel® Ethernet Connection > Power Management. And the "PCI Devices Power On" is enabled in UEFI SETUP UTILITY > Advanced > ACPI Configuration. After that, onboard LAN1&2 can wake up S5 under OS.



If you install Intel® LAN utility or Marvell SATA utility, this motherboard may fail Windows® Hardware Quality Lab (WHQL) certification tests. If you install the drivers only, it will pass the WHQL tests.

1.3 Unique Features

ASRock Rack Instant Flash is a BIOS flash utility embedded in Flash ROM. This convenient BIOS update tool allows you to update system BIOS without entering operating systems first like MS-DOS or Windows[®]. With this utility, you can press the <F6> key during the POST or the <F2> key to enter into the BIOS setup menu to access ASRock Rack Instant Flash. Just launch this tool and save the new BIOS file to your USB flash drive, floppy disk or hard drive, then you can update your BIOS only in a few clicks without preparing an additional floppy diskette or other complicated flash utility. Please be noted that the USB flash drive or hard drive must use FAT32/16/12 file system.

1.4 Motherboard Layout

Z690D4U-2L2T/G5 / W680D4U-2L2T/G5 /
 Z690D4U-2L2T/G5/BCM / W680D4U-2L2T/G5/BCM

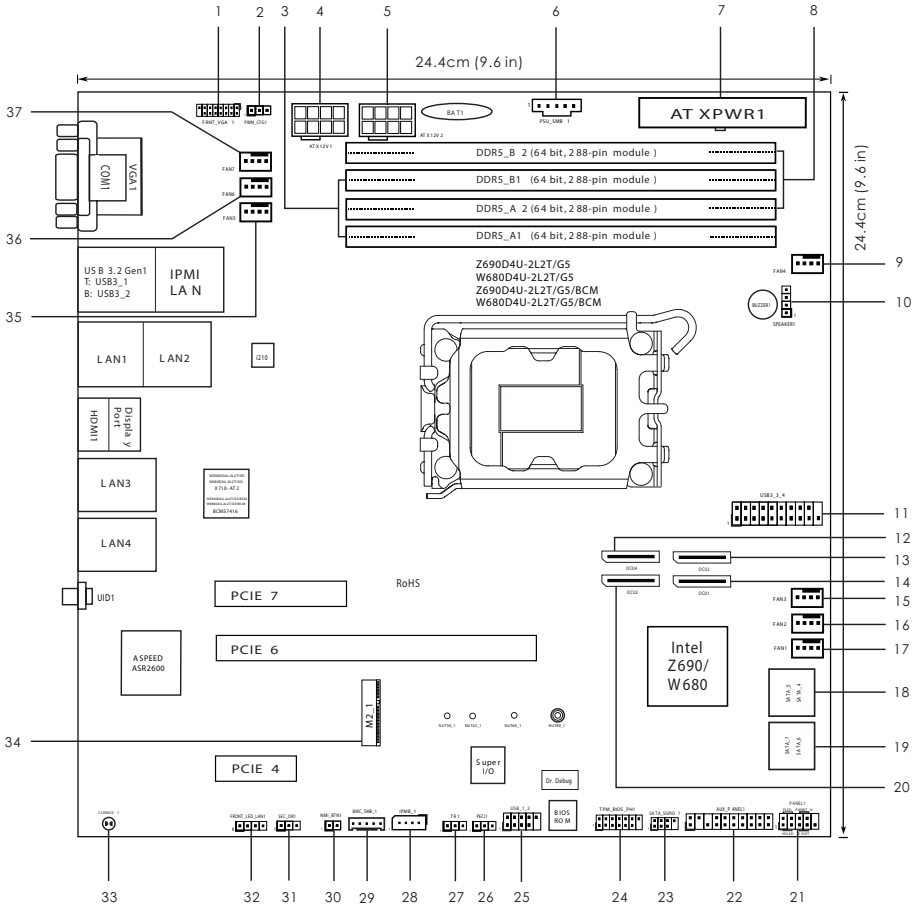

No.	Description
1	Front VGA Header (FRNT_VGA1)
2	PWM Configuration Header (PWM_CFG1)
3	2 x 288-pin DDR5 DIMM Slots (DDR5_A1, DDR5_B1)
4	ATX 12V Power Connector (ATX12V1)
5	ATX 12V Power Connector (ATX12V2)
6	PSU SMBus Header (PSU_SMB1)
7	ATX Power Connector (ATXPWR1)
8	2 x 288-pin DDR5 DIMM Slots (DDR5_A2, DDR5_B2)
9	Chassis Fan Connector (FAN4)
10	Chassis Speaker Header (SPEAKER1)
11	USB 3.2 Gen1 Header (USB3_3_4)
12	OCuLink x4 Connector (OCU4)
13	OCuLink x4 Connector (OCU3)
14	OCuLink x4 Connector (OCU1)
15	Chassis Fan Connector (FAN3)
16	Chassis Fan Connector (FAN2)
17	Chassis Fan Connector (FAN1)
18	SATA3 Connectors (SATA3_5)(Upper), (SATA3_4)(Lower)
19	SATA3 Connectors (SATA3_7)(Upper), (SATA3_6)(Lower)
20	OCuLink x4 Connector (OCU2)
21	System Panel Header (PANEL1)
22	Auxiliary Panel Header (AUX_PANEL1)
23	SATA SGPIO Connector (SATA_SGPIO1)
24	SPI TPM Header (TPM_BIOS_PH1)
25	USB 2.0 Header (USB_1_2)
26	CPU PECI Mode Jumper (PECI1)
27	Thermal Sensor Header (TR1)
28	Intelligent Platform Management Bus Header (IPMB_1)
29	BMC SMBus Header (BMC_SMB_1)
30	Non Maskable Interrupt Button (NMI_BTN1)
31	Security Override Jumper (SEC_OR1)
32	Front LAN LED Connector (FRONT_LED_LAN1)
33	Clear CMOS Pad (CLRMOS1)
34	M.2 Socket (M2_1) (Type 2230/2242/2260/2280)

No.	Description
35	Chassis Fan Connector (FAN5)
36	Chassis Fan Connector (FAN6)
37	Chassis Fan Connector (FAN7)

* For DIMM installation and configuration instructions, please see p.27 (Installation of Memory Modules (DIMM)) for more details.

Z690D4U/G5

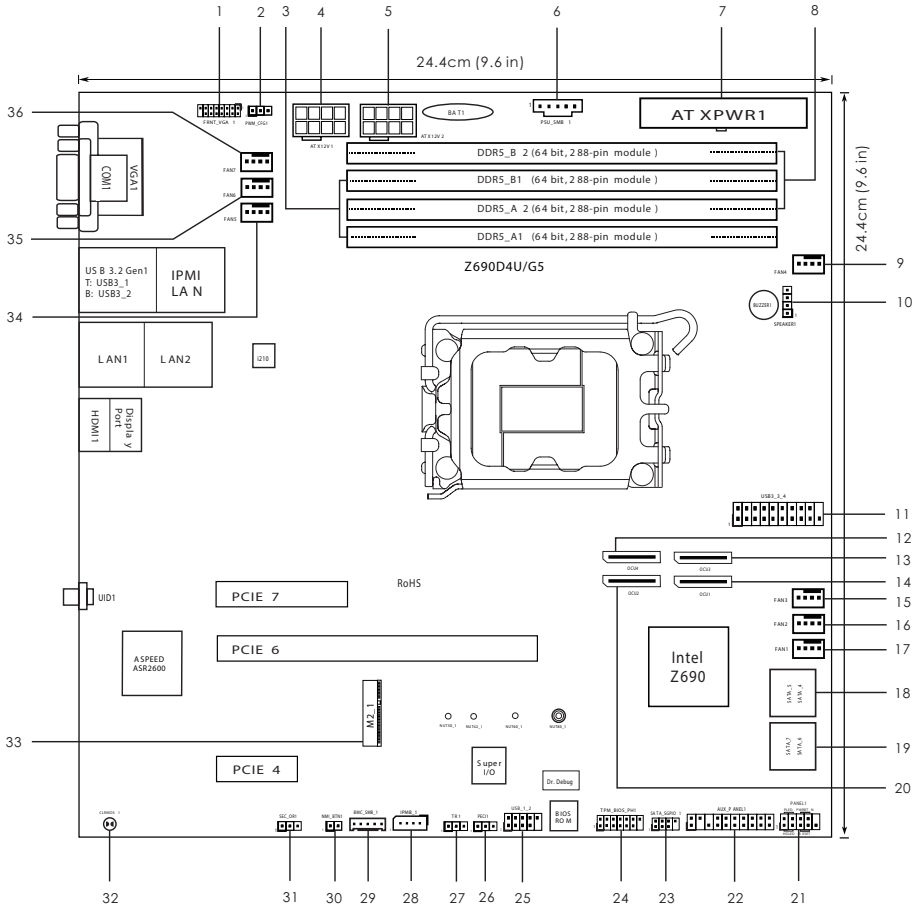

No.	Description
1	Front VGA Header (FRNT_VGA1)
2	PWM Configuration Header (PWM_CFG1)
3	2 x 288-pin DDR5 DIMM Slots (DDR5_A1, DDR5_B1)
4	ATX 12V Power Connector (ATX12V1)
5	ATX 12V Power Connector (ATX12V2)
6	PSU SMBus Header (PSU_SMB1)
7	ATX Power Connector (ATXPWR1)
8	2 x 288-pin DDR5 DIMM Slots (DDR5_A2, DDR5_B2)
9	Chassis Fan Connector (FAN4)
10	Chassis Speaker Header (SPEAKER1)
11	USB 3.2 Gen1 Header (USB3_3_4)
12	OCuLink x4 Connector (OCU4)
13	OCuLink x4 Connector (OCU3)
14	OCuLink x4 Connector (OCU1)
15	Chassis Fan Connector (FAN3)
16	Chassis Fan Connector (FAN2)
17	Chassis Fan Connector (FAN1)
18	SATA3 Connectors (SATA3_5)(Upper), (SATA3_4)(Lower)
19	SATA3 Connectors (SATA3_7)(Upper), (SATA3_6)(Lower)
20	OCuLink x4 Connector (OCU2)
21	System Panel Header (PANEL1)
22	Auxiliary Panel Header (AUX_PANEL1)
23	SATA SGPIO Connector (SATA_SGPIO1)
24	SPI TPM Header (TPM_BIOS_PH1)
25	USB 2.0 Header (USB_1_2)
26	CPU PECl Mode Jumper (PECl1)
27	Thermal Sensor Header (TR1)
28	Intelligent Platform Management Bus Header (IPMB_1)
29	BMC SMBus Header (BMC_SMB_1)
30	Non Maskable Interrupt Button (NMI_BTN1)
31	Security Override Jumper (SEC_OR1)
32	Clear CMOS Pad (CLRMOSt)
33	M.2 Socket (M2_1) (Type 2230/2242/2260/2280)
34	Chassis Fan Connector (FAN5)

No.	Description
35	Chassis Fan Connector (FAN6)
36	Chassis Fan Connector (FAN7)

** For DIMM installation and configuration instructions, please see p.27 (Installation of Memory Modules (DIMM)) for more details.*

1.5 Onboard LED Indicators

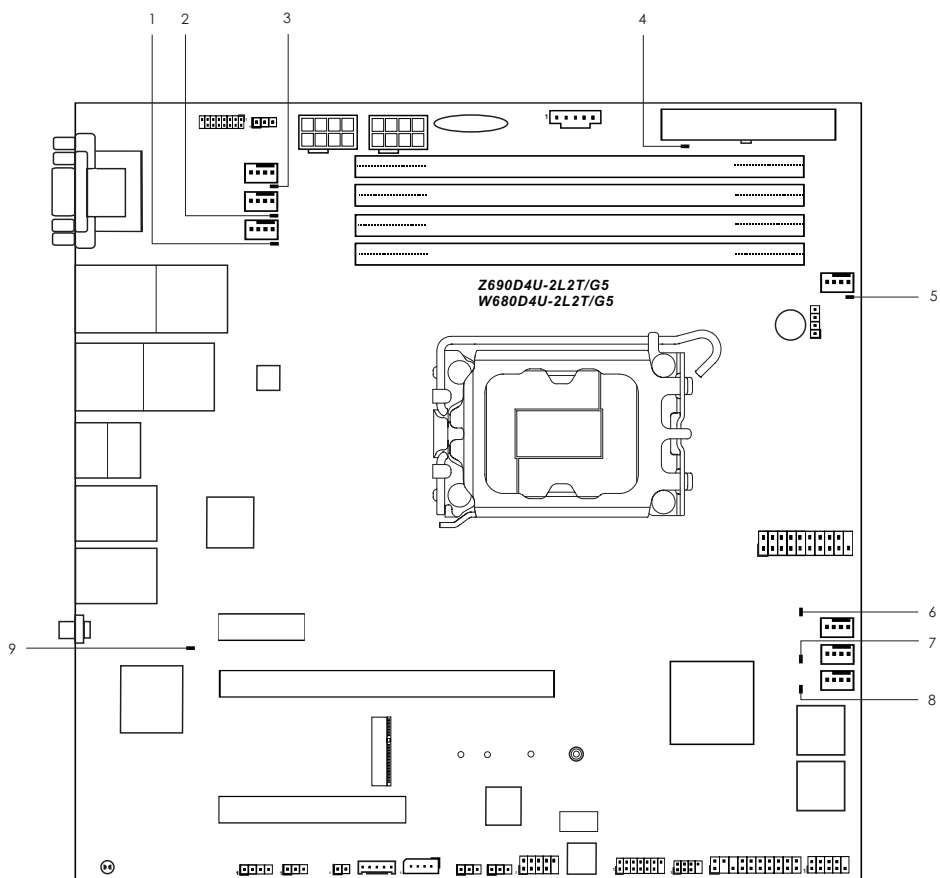

No.	Item	Status	Description
1	FAN5_LED1	Red	FAN5 failed
2	FAN6_LED1	Red	FAN6 failed
3	FAN7_LED1	Red	FAN7 failed
4	SB_PWR1	Green	STB PWR ready
5	FAN4_LED1	Red	FAN4 failed
6	FAN3_LED1	Red	FAN3 failed
7	FAN2_LED1	Red	FAN2 failed
8	FAN1_LED1	Red	FAN1 failed
9	BMC_LED1	Green	BMC heartbeat LED

1.6 I/O Panel

Z690D4U-2L2T/G5 / W680D4U-2L2T/G5
 Z690D4U-2L2T/G5/BCM / W680D4U-2L2T/G5/BCM

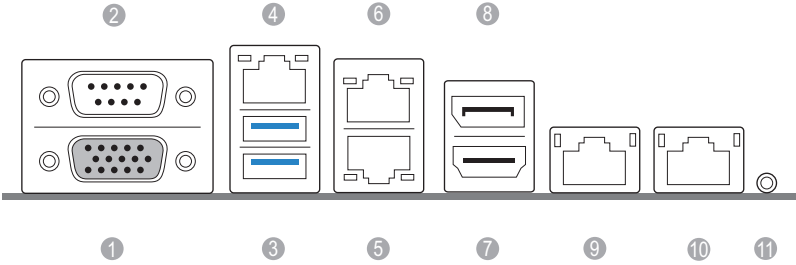

No.	Description	No.	Description
1	VGA Port (VGA1)	7	HDMI Port (1.4b)
2	Serial Port (COM1)	8	Display Port (1.4a)
3	USB 3.2 Gen1 Ports (USB3_1_2)	9	10G LAN RJ-45 Port (LAN3)**
4	LAN RJ-45 Port (IPMI_LAN)*	10	10G LAN RJ-45 Port (LAN4)**
5	1G LAN RJ-45 Port (LAN1, shared NIC)***	11	UID Switch (UID1)
6	1G LAN RJ-45 Port (LAN2)***		

Z690D4U/G5

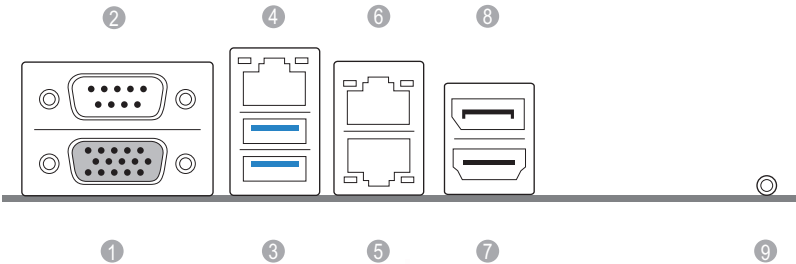

No.	Description	No.	Description
1	VGA Port (VGA1)	6	1G LAN RJ-45 Port (LAN2)***
2	Serial Port (COM1)	7	HDMI Port (1.4b)
3	USB 3.2 Gen1 Ports (USB3_1_2)	8	Display Port (1.4a)
4	LAN RJ-45 Port (IPMI_LAN)*	9	UID Switch (UID1)
5	1G LAN RJ-45 Port (LAN1, shared NIC)***		

LAN Port LED Indications

*There are two LED next to the LAN port. Please refer to the table below for the LAN port LED indications.

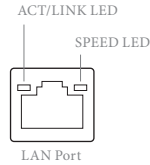

Dedicated IPMI LAN Port LED Indications

Activity / Link LED		Speed LED	
Status	Description	Status	Description
Off	No Link	Off	10M bps connection or no link
Blinking Yellow	Data Activity	Yellow	100M bps connection
On	Link	Green	1Gbps connection

**There are two LEDs on each LAN port. Please refer to the table below for the LAN port LED indications.

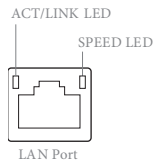

10G LAN Port LED Indications (Z690D4U-2L2TG5 / W680D4U-2L2T/G5 only)

Activity / Link LED		Speed LED	
Status	Description	Status	Description
Off	No Link	Off	100Mbps Connection or No Link
Blinking Green	Data Activity	Yellow	1Gbps Connection
On	Link	Green	10Gbps Connection

10G LAN Port LED Indications (Z690D4U-2L2TG5/BCM / W680D4U-2L2T/G5/BCM only)

Activity / Link LED		Speed LED	
Status	Description	Status	Description
Off	No Link	Off	No Link
Blinking Green	Data Activity	Amber	1Gbps Connection
On	Link	Green	10Gbps Connection

***There are two LEDs on each LAN port. Please refer to the table below for the LAN port LED indications.

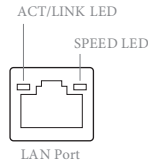

1G LAN Port LED Indications

Activity / Link LED		Speed LED	
Status	Description	Status	Description
Off	No Link	Off	10Mbps connection or no link
Blinking Orange	Data Activity	Yellow	100Mbps connection
On	Link	Green	1Gbps connection

1.7 Block Diagram

Z690D4U/G5 / Z690D4U-2L2T/G5 / W680D4U-2L2T/G5

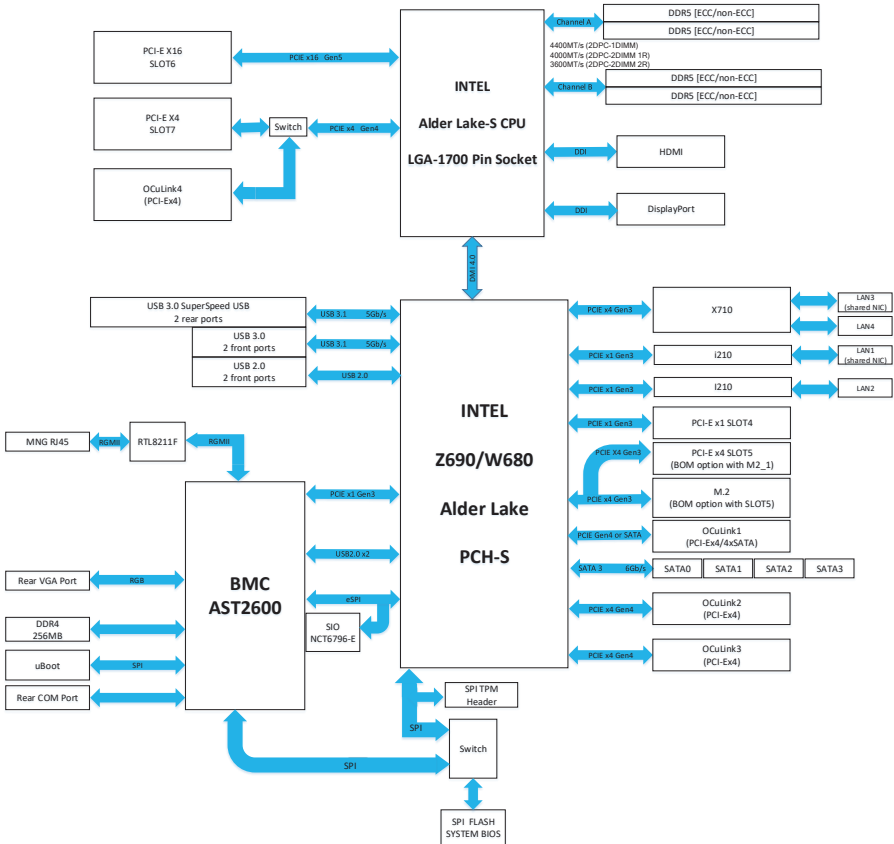

Z690D4U-2L2T/G5/BCM / W680D4U-2L2T/G5/BCM

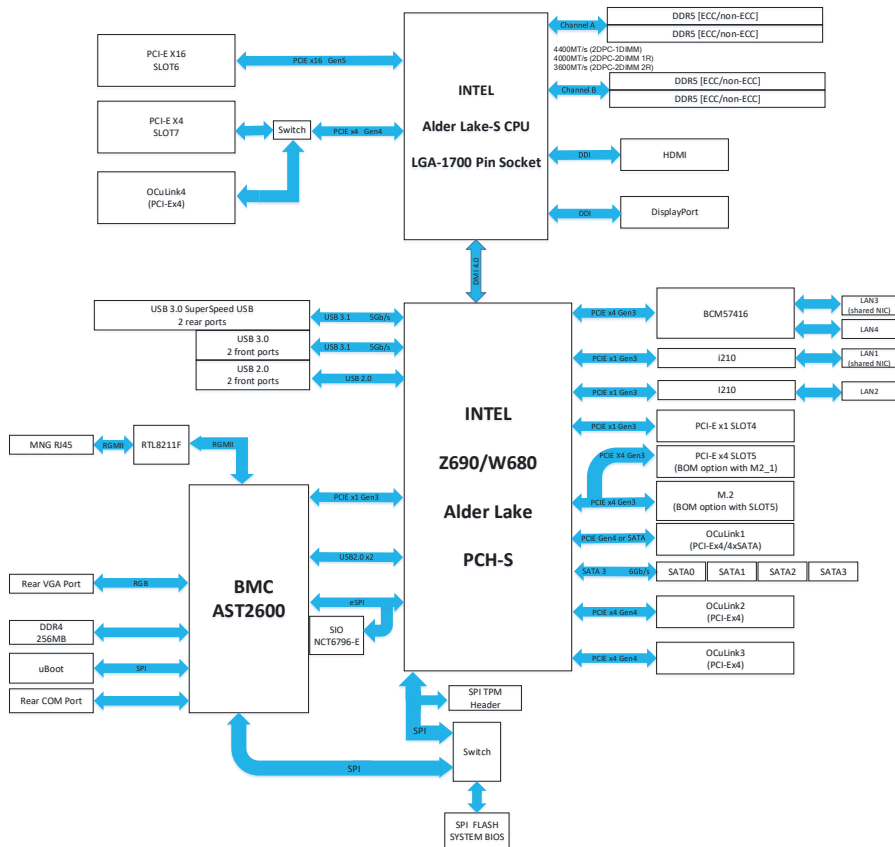

Chapter 2 Installation

This is a mATX form factor (9.6" x 9.6", 24.4 cm x 24.4 cm) motherboard. Before you install the motherboard, study the configuration of your chassis to ensure that the motherboard fits into it.



Make sure to unplug the power cord before installing or removing the motherboard. Failure to do so may cause physical injuries to you and damages to motherboard components.

2.1 Screw Holes

Place screws into the holes indicated by circles to secure the motherboard to the chassis.



Do not over-tighten the screws! Doing so may damage the motherboard.

2.2 Pre-installation Precautions

Take note of the following precautions before you install motherboard components or change any motherboard settings.

1. Unplug the power cord from the wall socket before touching any components.
2. To avoid damaging the motherboard's components due to static electricity, NEVER place your motherboard directly on the carpet or the like. Also remember to use a grounded wrist strap or touch a safety grounded object before you handle the components.
3. Hold components by the edges and do not touch the ICs.
4. Whenever you uninstall any component, place it on a grounded anti-static pad or in the bag that comes with the component.
5. When placing screws into the screw holes to secure the motherboard to the chassis, please do not over-tighten the screws! Doing so may damage the motherboard.



Before you install or remove any component, ensure that the power is switched off or the power cord is detached from the power supply. Failure to do so may cause severe damage to the motherboard, peripherals, and/or components.

2.3 Installing the CPU



1. Before you insert the 1700-Pin CPU into the socket, please check if the **PnP cap** is on the socket, if the CPU surface is unclean, or if there are any **bent pins** in the socket. Do not force to insert the CPU into the socket if above situation is found. Otherwise, the CPU will be seriously damaged.
2. Unplug all power cables before installing the CPU.

1

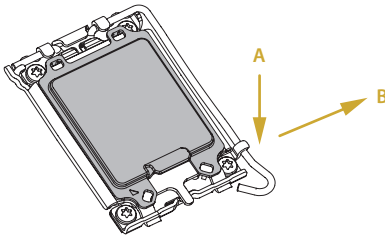

2

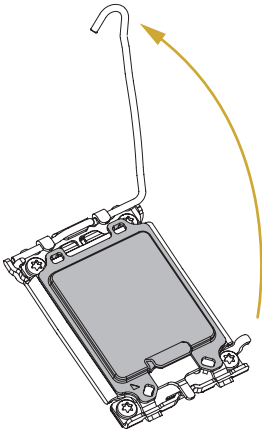

3

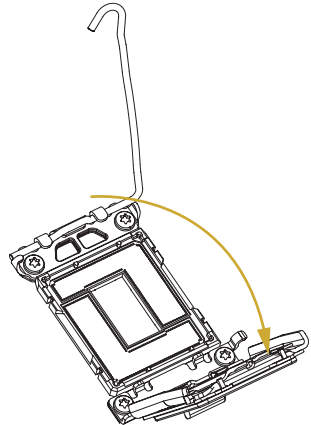

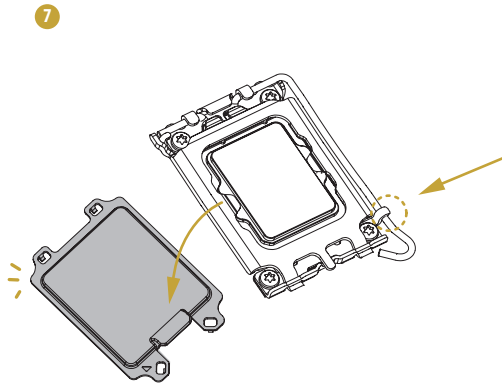
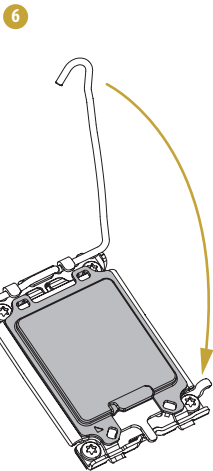
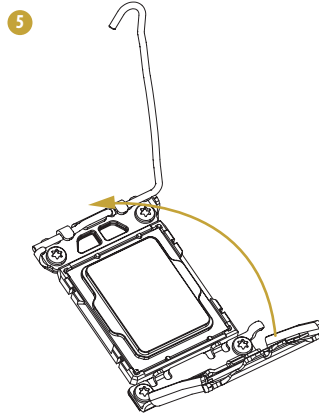
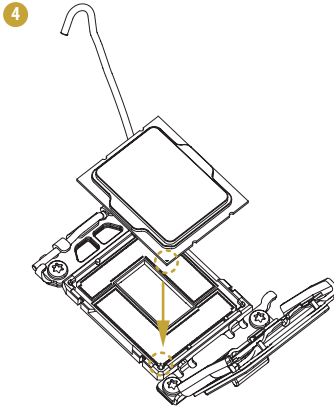

Please save and replace the cover if the processor is removed. The cover must be placed if you wish to return the motherboard for after service.

2.4 Installing the CPU Fan and Heatsink

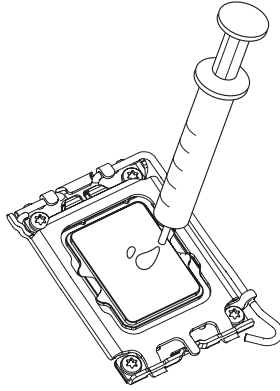

1

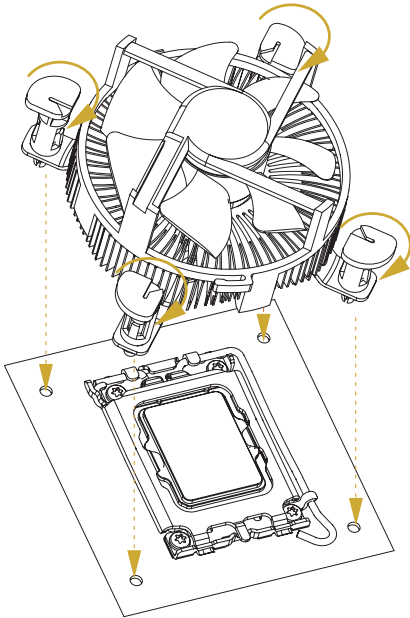

2

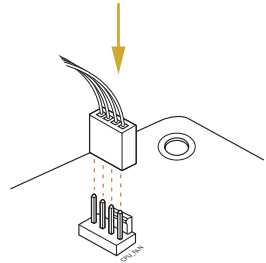

2.5 Installing Memory Modules (DIMM)

This motherboard provides four 288-pin DDR5 (Double Data Rate 5) DIMM slots, and supports Dual Channel Memory Technology.



1. For dual channel configuration, you always need to install identical (the same brand, speed, size and chip-type) DDR5 DIMM pairs.
2. It is unable to activate Dual Channel Memory Technology with only one or three memory module installed.
3. It is not allowed to install a DDR, DDR2, DDR3 or DDR4 memory module into a DDR5 slot; otherwise, this motherboard and DIMM may be damaged.

Dual Channel Memory Configuration

Priority	DDR5_A1	DDR5_A2	DDR5_B1	DDR5_B2
1		Populated		Populated
2	Populated	Populated	Populated	Populated



The DIMM only fits in one correct orientation. It will cause permanent damage to the motherboard and the DIMM if you force the DIMM into the slot at incorrect orientation.

1

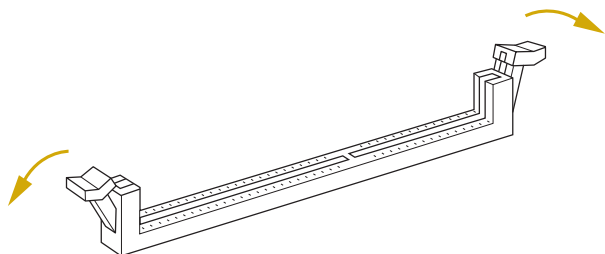

2

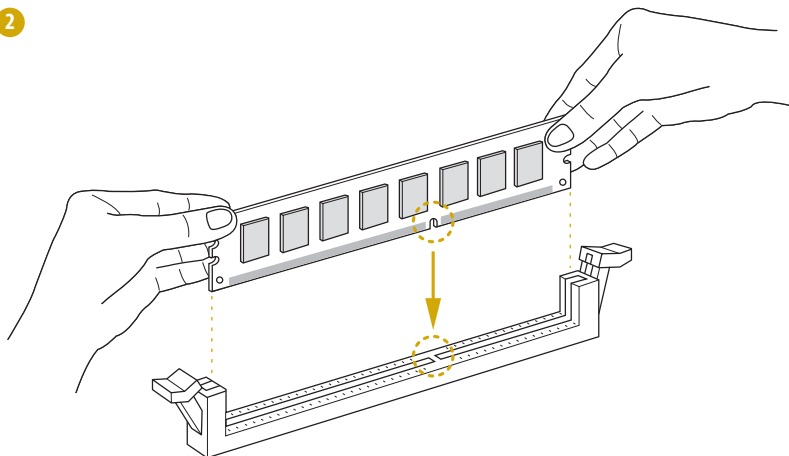

3

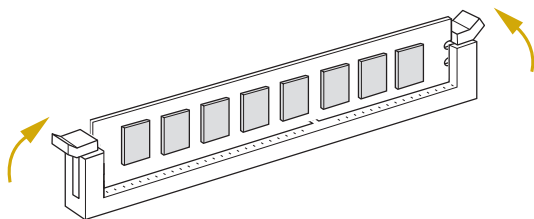

The DIMM only fits in one correct orientation. It will cause permanent damage to the motherboard and the DIMM if you force the DIMM into the slot at incorrect orientation.

2.6 Expansion Slots (PCI Express Slots)

There are 4 PCI Express slots on this motherboard.

PCIe slot:

PCIe4 (PCIe 3.0 x1 slot) is used for PCI Express x1 lane width cards.

PCIe6 (PCIe 5.0 x16 slot) is used for PCI Express x16 lane width cards.

PCIe7 (PCIe 4.0 x4 slot) is used for PCI Express x4 lane width cards.

Slot	Generation	Mechanical	Electrical	Source
PCIe 7	4.0	x4	x4	CPU
PCIe 6	5.0	x16	x16	CPU
PCIe 4	3.0	x1	x1	PCH

Installing an expansion card

- Step 1. Before installing an expansion card, please make sure that the power supply is switched off or the power cord is unplugged. Please read the documentation of the expansion card and make necessary hardware settings for the card before you start the installation.
- Step 2. Remove the system unit cover (if your motherboard is already installed in a chassis).
- Step 3. Remove the bracket facing the slot that you intend to use. Keep the screws for later use.
- Step 4. Align the card connector with the slot and press firmly until the card is completely seated on the slot.
- Step 5. Fasten the card to the chassis with screws.
- Step 6. Replace the system cover.

2.7 Jumper Setup

The illustration shows how jumpers are setup. When the jumper cap is placed on the pins, the jumper is “Short”. If no jumper cap is placed on the pins, the jumper is “Open”. The illustration shows a 3-pin jumper whose pin1 and pin2 are “Short” when a jumper cap is placed on these 2 pins.

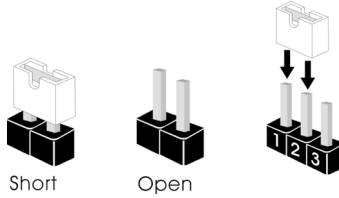

ME Recovery Jumper
(3-pin ME_RECOVERY1)



Normal Mode (Default)



ME force update

CPU PECI Mode Jumper
(3-pin PECI1)



CPU PECI connected to
PCH



CPU PECI connected to
BMC (Default)

2.8 Onboard Headers and Connectors



Onboard headers and connectors are NOT jumpers. Do NOT place jumper caps over these headers and connectors. Placing jumper caps over the headers and connectors will cause permanent damage to the motherboard.

System Panel Header (9-pin PANEL1)

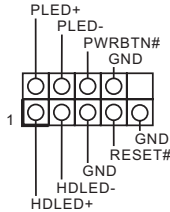

Connect the power switch, reset switch and system status indicator on the chassis to this header according to the pin assignments. Particularly note the positive and negative pins before connecting the cables.



PWRBTN (Power Switch):

Connect to the power switch on the chassis front panel. You may configure the way to turn off your system using the power switch.

RESET (Reset Switch):

Connect to the reset switch on the chassis front panel. Press the reset switch to restart the computer if the computer freezes and fails to perform a normal restart.

PLED (System Power LED):

Connect to the power status indicator on the chassis front panel. The LED is on when the system is operating. The LED is off when the system is in S4 sleep state or powered off (S5).

HDLED (Hard Drive Activity LED):

Connect to the hard drive activity LED on the chassis front panel. The LED is on when the hard drive is reading or writing data.

The front panel design may differ by chassis. A front panel module mainly consists of power switch, reset switch, power LED, hard drive activity LED, speaker and etc. When connecting your chassis front panel module to this header, make sure the wire assignments and the pin assignments are matched correctly.

Auxiliary Panel Header (18-pin AUX PANEL1)

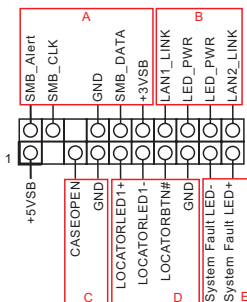

This header supports multiple functions on the front panel, including the front panel SMB, internet status indicator and chassis intrusion pin.



A. Front panel SMBus connecting pin (6-1 pin FPSMB)

This header allows you to connect SMBus (System Management Bus) equipment. It can be used for communication between peripheral equipment in the system, which has slower transmission rates, and power management equipment.

B. Internet status indicator (2-pin LAN1_LED, LAN2_LED)

These two 2-pin headers allow you to use the Gigabit internet indicator cable to connect to the LAN status indicator. When this indicator flickers, it means that the internet is properly connected.

C. Chassis intrusion pin (2-pin CHASSIS)

This header is provided for host computer chassis with chassis intrusion detection designs. In addition, it must also work with external detection equipment, such as a chassis intrusion detection sensor or a microswitch. When this function is activated, if any chassis component movement occurs, the sensor will immediately detect it and send a signal to this header, and the system will then record this chassis intrusion event. The default setting is set to the CASEOPEN and GND pin; this function is off.

D. Locator LED (4-pin LOCATOR)

This header is for the locator switch and LED on the front panel.

E. System Fault LED (2-pin LOCATOR)

This header is for the Fault LED on the system.

ATX 12V Power
Connectors
(8-pin ATX12V1)
(8-pin ATX12V2)

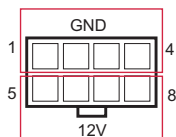

This motherboard provides two 8-pin ATX 12V power connectors.

SPI TPM Header
(13-pin TPM_BIOS_PH1)

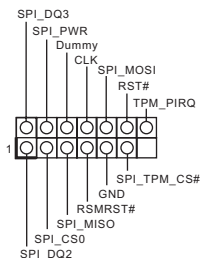

This connector supports SPI Trusted Platform Module (TPM) system, which can securely store keys, digital certificates, passwords, and data. A TPM system also helps enhance network security, protects digital identities, and ensures platform integrity.

Serial General Purpose
Input/Output Header
(7-pin SATA_SGPIO1)

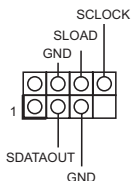

The header supports Serial Link interface for onboard SATA connections.

PSU SMBus
(PSU_SMB1)
(see p.7, No. 3)

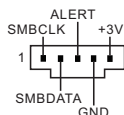

PSU SMBus monitors the status of the power supply, fan and system temperature.

Non Maskable Interrupt
Button Header
(NMI_BTN1)



Please connect a NMI device to this header.

PWM Configuration
Header
(3-pin PWM_CFG1)

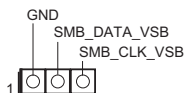

This header is used for PWM configurations.

Intelligent Platform
Management Bus Header
(4-pin IPMB_1)

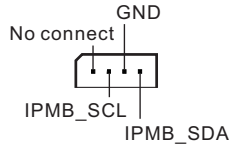

This 4-pin connector is used to provide a cabled base-board or front panel connection for value added features and 3rd-party add-in cards, such as Emergency Management cards, that provide management features using the IPMB.

Baseboard Management
Controller SMBus Header
(5-pin BMC_SMB_1)

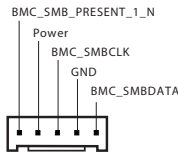

The header is used for the SMBUS devices.

Thermal Sensor Header
(3-pin TR1)



Please connect the thermal sensor cable to either pin 1-2 or pin 2-3 and the other end to the device which you wish to monitor its temperature.

OCuLink Connectors
(OCU1)
(OCU2)
(OCU3)
(OCU4)

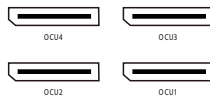

Please connect PCIE SSDs or OCuLink-to-SATA x4 cable to the connectors.

USB 3.2 Gen1 Header
(19-pin USB3_3_4)

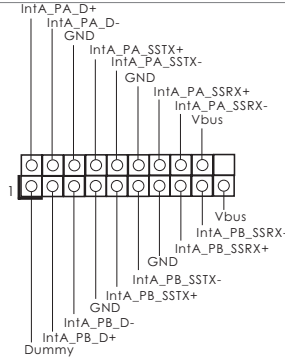

Besides two default USB 3.2 Gen1 ports on the I/O panel, there is one USB 3.2 Gen1 header on this motherboard. This USB 3.2 Gen1 header can support two USB 3.2 Gen1 ports.

Front VGA Header
(15-pin FRNT_VGA1)

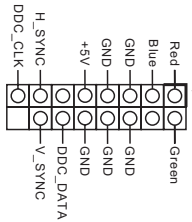

Please connect either end of VGA_2X8 cable to VGA header.

Front LAN LED
Connector
(FRONT_LED_LAN1)

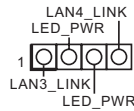

This 4-pin connector is used for the front LAN status indicator.

Clear CMOS Pad
(CLRMOI1)



CLRMOI1 allows you to clear the data in CMOS. To clear CMOS, take out the CMOS battery and short the Clear CMOS Pad.

2.9 Dr. Debug

Dr. Debug is used to provide code information, which makes troubleshooting even easier. Please see the diagrams below for reading the Dr. Debug codes.

Code	Description
0x10	PEI_CORE_STARTED
0x11	PEI_CAR_CPU_INIT
0x15	PEI_CAR_NB_INIT
0x19	PEI_CAR_SB_INIT
0x31	PEI_MEMORY_INSTALLED
0x32	PEI_CPU_INIT
0x33	PEI_CPU_CACHE_INIT
0x34	PEI_CPU_AP_INIT
0x35	PEI_CPU_BSP_SELECT
0x36	PEI_CPU_SMM_INIT
0x37	PEI_MEM_NB_INIT
0x3B	PEI_MEM_SB_INIT
0x4F	PEI_DXE_IPL_STARTED
0x60	DXE_CORE_STARTED
0x61	DXE_NVRAM_INIT
0x62	DXE_SBRUN_INIT

0x63 DXE_CPU_INIT

0x68 DXE_NB_HB_INIT

0x69 DXE_NB_INIT

0x6A DXE_NB_SMM_INIT

0x70 DXE_SB_INIT

0x71 DXE_SB_SMM_INIT

0x72 DXE_SB_DEVICES_INIT

0x78 DXE_ACPI_INIT

0x79 DXE_CSM_INIT

0x90 DXE_BDS_STARTED

0x91 DXE_BDS_CONNECT_DRIVERS

0x92 DXE_PCI_BUS_BEGIN

0x93 DXE_PCI_BUS_HPC_INIT

0x94 DXE_PCI_BUS_ENUM

0x95 DXE_PCI_BUS_REQUEST_RESOURCES

0x96 DXE_PCI_BUS_ASSIGN_RESOURCES

0x97 DXE_CON_OUT_CONNECT

0x98 DXE_CON_IN_CONNECT

0x99	DXE_SIO_INIT
0x9A	DXE_USB_BEGIN
0x9B	DXE_USB_RESET
0x9C	DXE_USB_DETECT
0x9D	DXE_USB_ENABLE
0xA0	DXE_IDE_BEGIN
0xA1	DXE_IDE_RESET
0xA2	DXE_IDE_DETECT
0xA3	DXE_IDE_ENABLE
0xA4	DXE_SCSI_BEGIN
0xA5	DXE_SCSI_RESET
0xA6	DXE_SCSI_DETECT
0xA7	DXE_SCSI_ENABLE
0xA8	DXE_SETUP_VERIFYING_PASSWORD
0xA9	DXE_SETUP_START
0xAB	DXE_SETUP_INPUT_WAIT
0xAD	DXE_READY_TO_BOOT
0xAE	DXE_LEGACY_BOOT

0xAF	DXE_EXIT_BOOT_SERVICES
0xB0	RT_SET_VIRTUAL_ADDRESS_MAP_BEGIN
0xB1	RT_SET_VIRTUAL_ADDRESS_MAP_END
0xB2	DXE_LEGACY_OPROM_INIT
0xB3	DXE_RESET_SYSTEM
0xB4	DXE_USB_HOTPLUG
0xB5	DXE_PCI_BUS_HOTPLUG
0xB6	DXE_NVRAM_CLEANUP
0xB7	DXE_CONFIGURATION_RESET
0xF0	PEI_RECOVERY_AUTO
0xF1	PEI_RECOVERY_USER
0xF2	PEI_RECOVERY_STARTED
0xF3	PEI_RECOVERY_CAPSULE_FOUND
0xF4	PEI_RECOVERY_CAPSULE_LOADED
0xE0	PEI_S3_STARTED
0xE1	PEI_S3_BOOT_SCRIPT
0xE2	PEI_S3_VIDEO_REPOST

0xE3	PEI_S3_OS_WAKE
0x50	PEI_MEMORY_INVALID_TYPE
0x53	PEI_MEMORY_NOT_DETECTED
0x55	PEI_MEMORY_NOT_INSTALLED
0x57	PEI_CPU_MISMATCH
0x58	PEI_CPU_SELF_TEST_FAILED
0x59	PEI_CPU_NO_MICROCODE
0x5A	PEI_CPU_ERROR
0x5B	PEI_RESET_NOT_AVAILABLE
0xD0	DXE_CPU_ERROR
0xD1	DXE_NB_ERROR
0xD2	DXE_SB_ERROR
0xD3	DXE_ARCH_PROTOCOL_NOT_AVAILABLE
0xD4	DXE_PCI_BUS_OUT_OF_RESOURCES
0xD5	DXE_LEGACY_OPROM_NO_SPACE
0xD6	DXE_NO_CON_OUT
0xD7	DXE_NO_CON_IN

0xD8	DXE_INVALID_PASSWORD
0xD9	DXE_BOOT_OPTION_LOAD_ERROR
0xDA	DXE_BOOT_OPTION_FAILED
0xDB	DXE_FLASH_UPDATE_FAILED
0xDC	DXE_RESET_NOT_AVAILABLE
0xE8	PEI_MEMORY_S3_RESUME_FAILED
0xE9	PEI_S3_RESUME_PPI_NOT_FOUND
0xEA	PEI_S3_BOOT_SCRIPT_ERROR
0xEB	PEI_S3_OS_WAKE_ERROR

2.10 Unit Identification purpose LED/Switch

With the UID button, You are able to locate the server you're working on from behind a rack of servers.

Unit Identification
purpose LED/Switch
(UID)



When the UID button on the front or rear panel is pressed, the front/rear UID blue LED indicator will be turned on. Press the UID button again to turn off the indicator.



Press and hold the UID button for 4 seconds, the BMC will trigger an external reset.

2.11 Dua LAN and Teaming Operation Guide

Dual LAN with Teaming enabled on this motherboard allows two single connections to act as one single connection(s) for twice the transmission bandwidth, making data transmission more effective and improving the quality of transmission of distant images. Fault tolerance on the dual LAN network prevents network downtime by transferring the workload from a failed port to a working port.



The speed of transmission is subject to the actual network environment or status even with Teaming enabled.

Before setting up Teaming, please make sure whether your Switch (or Router) supports Teaming (IEEE 802.3ad Link Aggregation). You can specify a preferred adapter in Intel PROSet. Under normal conditions, the Primary adapter handles all non-TCP/IP traffic. The Secondary adapter will receive fallback traffic if the primary fails. If the Preferred Primary adapter fails, but is later restored to an active status, control is automatically switched back to the Preferred Primary adapter.

Step 1

From **Device Manager**, open the properties of a team.

Step 2

Click the **Settings** tab.

Step 3

Click the **Modify Team** button.

Step 4

Select the adapter you want to be the primary adapter and click the **Set Primary** button.

If you do not specify a preferred primary adapter, the software will choose an adapter of the highest capability (model and speed) to act as the default primary. If a failover occurs, another adapter becomes the primary. The adapter will, however, rejoin the team as a non-primary.

2.12 M.2 SSD Module Installation Guide (M2_1)

The Ultra M.2 Socket (M2_1, Key M) supports type 2230/2242/2260/2280 M.2 PCI Express module up to Gen3 x4 (32GT/s) [PCH].

Installing the M.2 SSD Module



Step 1

Prepare a M.2 SSD module and the screw.

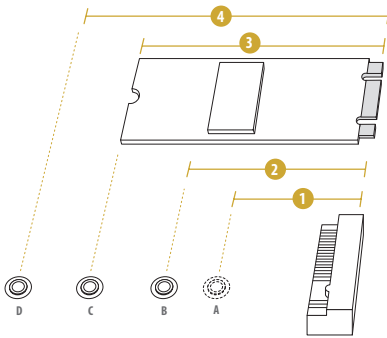

Step 2

Depending on the PCB type and length of your M.2 SSD module, find the corresponding nut location to be used.

No.	1	2	3	4
Nut Location	A	B	C	D
PCB Length	3cm	4.2cm	6cm	8cm
Module Type	Type2230	Type 2242	Type2260	Type 2280

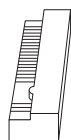

Step 3

Move the standoff based on the module type and length. The standoff is placed at the nut location D by default. Skip Step 3 and 4 and go straight to Step 5 if you are going to use the default nut. Otherwise, release the standoff by hand.

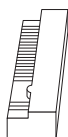

Step 4

Peel off the yellow protective film on the nut to be used. Hand tighten the standoff into the desired nut location on the motherboard.

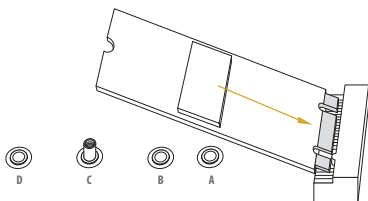

Step 5

Align and gently insert the M.2 SSD module into the M.2 slot. Please be aware that the M.2 SSD module only fits in one orientation.

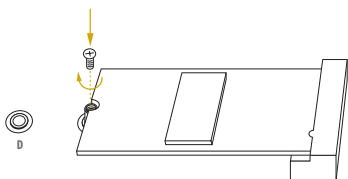
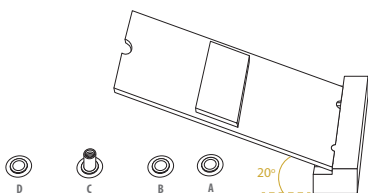

Step 6

Tighten the screw with a screwdriver to secure the module into place. Please do not overtighten the screw as this might damage the module.

Chapter 3 UEFI Setup Utility

3.1 Introduction

This section explains how to use the UEFI SETUP UTILITY to configure your system. The UEFI chip on the motherboard stores the UEFI SETUP UTILITY. You may run the UEFI SETUP UTILITY when you start up the computer. Please press <F2> or during the Power-On-Self-Test (POST) to enter the UEFI SETUP UTILITY; otherwise, POST will continue with its test routines.

If you wish to enter the UEFI SETUP UTILITY after POST, restart the system by pressing <Ctrl> + <Alt> + <Delete>, or by pressing the reset button on the system chassis. You may also restart by turning the system off and then back on.



Because the UEFI software is constantly being updated, the following UEFI setup screens and descriptions are for reference purpose only, and they may not exactly match what you see on your screen.

3.1.1 UEFI Menu Bar

The top of the screen has a menu bar with the following selections:

Item	Description
Main	To set up the system time/date information
OC Tweaker	For overclocking configurations
Advanced	To set up the advanced UEFI features
Security	To set up the security features
Boot	To set up the default system device to locate and load the Operating System
Server Mgmt	To manage the server
Event Logs	For event log configuration
Exit	To exit the current screen or the UEFI SETUP UTILITY

Use <←> key or <→> key to choose among the selections on the menu bar, and then press <Enter> to get into the sub screen.

3.1.2 Navigation Keys

Please check the following table for the function description of each navigation key.

Navigation Key(s)	Function Description
← / →	Moves cursor left or right to select Screens
↑ / ↓	Moves cursor up or down to select items
+ / -	To change option for the selected items
<Tab>	Switch to next function
<Enter>	To bring up the selected screen
<PGUP>	Go to the previous page
<PGDN>	Go to the next page
<HOME>	Go to the top of the screen
<END>	Go to the bottom of the screen
<F1>	To display the General Help Screen
<F7>	Discard changes and exit the UEFI SETUP UTILITY
<F9>	Load optimal default values for all the settings
<F10>	Save changes and exit the UEFI SETUP UTILITY
<F12>	Print screen
<ESC>	Jump to the Exit Screen or exit the current screen

3.2 Main Screen

Once you enter the UEFI SETUP UTILITY, the Main screen will appear and display the system overview. The Main screen provides system overview information and allows you to set the system time and date.

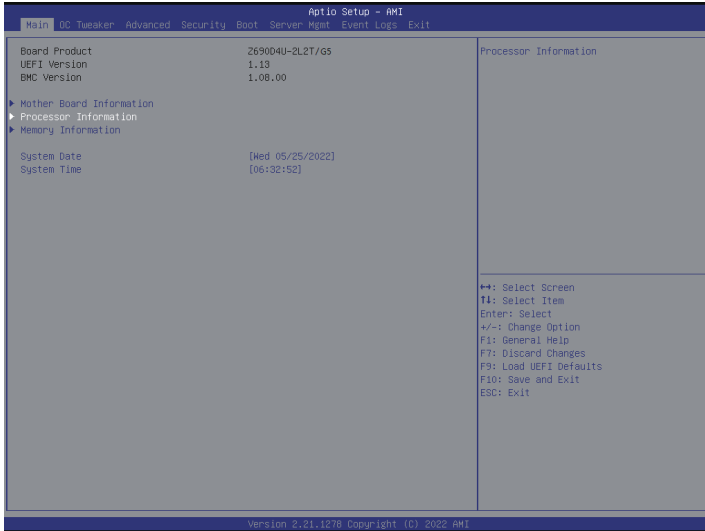

Mother Board Information

Enter this item to view the motherboard information.

Processor Information

Enter this item to view the processor information.

Memory Information

Enter this item to view the memory information.

Note: The screenshots in this user manual are examples and for references only. The actual images may slightly vary depending on the model and the version you use.

3.3 OC Tweaker

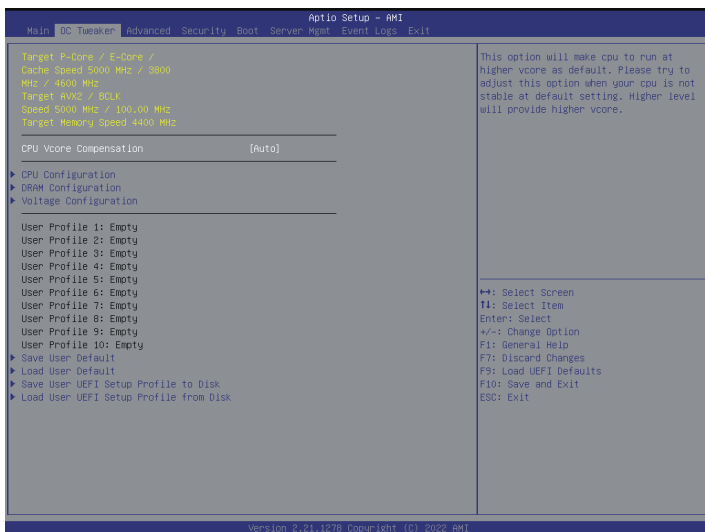

CPU Vcore Compensation

This option will make cpu to run at higher vcores as default. Please try to adjust this option when your cpu is not stable at default setting. Higher level will provide higher vcore.

Save User Default

Type a profile name and press enter to save your settings as user default.

Load User Default

Load previously saved user defaults.

Save User UEFI Setup Profile to Disk

It helps you to save current UEFI settings as an user profile to disk.

Load User UEFI Setup Profile from Disk

You can load previous saved profile from the disk.

3.3.1 CPU Configuration

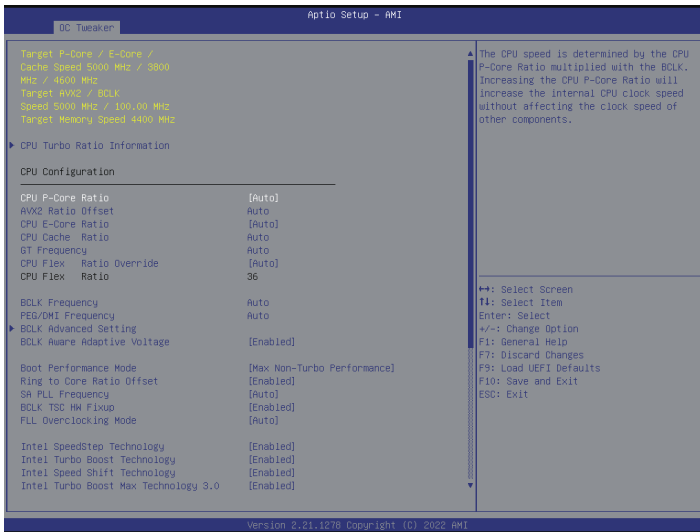

CPU Turbo Ratio Information

The CPU speed is determined by the CPU P-Core Ratio multiplied with the BCLK. Increasing the CPU P-Core Ratio will increase the internal CPU clock speed without affecting the clock speed of other components.

CPU P-Core Ratio

The CPU speed is determined by the CPU P-Core Ratio multiplied with the BCLK. Increasing the CPU P-Core Ratio will increase the internal CPU clock speed without affecting the clock speed of other components.

AVX2 Ratio Offset

AVX2 Ratio Offset specifies a negative offset from the CPU Ratio for AVX workloads. AVX is a more stressful workload that lower the AVX ratio to ensure maximum possible ratio for SSE workloads.

CPU E-Core Ratio

The E-Core speed is determined by the E-Core Ratio multiplied with the BCLK. Increasing the E-Core Ratio will increase the internal E-Core clock speed without affecting the clock speed of other components.

CPU Cache Ratio

The CPU Internal Bus Speed Ratio. The maximum should be the same as the CPU Ratio.

GT Frequency

Configure the frequency of the integrated GPU in MHz.

CPU Flex Ratio Override

Enable/Disable CPU Flex Ratio Programming. Flex Ratio can lower maximum non-turbo, especially for CPU without turbo function.

BCLK Frequency

The CPU speed is determined by the CPU Ratio multiplied with the BCLK. Increasing the BCLK will increase the internal CPU clock speed but also affect the clock speed of other components.

PEG/DMI Frequency

Configure the PEG/DMI Frequency setting.

BCLK Advanced Setting

Configure the BCLK Advanced setting.

BCLK SSC Mode

Configure the BCLK Spread Spectrum Mode setting.

BCLK Delay

After raising BCLK, BIOS adds a delay time (ms) for stability.

BCLK Aware Adaptive Voltage

BCLK Aware Adaptive Voltage enable/disable. When enabled, pcode will be aware of the BCLK frequency when calculating the CPU V/F curves. This is ideal for BCLK OC to avoid high voltage overrides.

Boot Performance Mode

Select the performance state that the BIOS will set before OS handoff. Max Battery mode will set CPU ratio as xB till OS handoff. This option is suggested for BCLK overclocking.

Ring to Core Ratio Offset

Disable Ring to Core Ratio Offset so the ring and core can run at the same frequency.

SA PLL Frequency Override

Configure SA PLL Frequency.

BCLK TSC HW Fixup

BCLK TSC HW Fixup disable during TSC copy from PMA to APIC.

FLL Overclocking Mode

Nominal is good for normal core ratio overclocking. Elevated and Extremely Elevated are good for high BCLK OC.

Intel SpeedStep Technology

Intel SpeedStep technology allows processors to switch between multiple frequencies and voltage points for better power saving and heat dissipation. CPU turbo ratio can be fixed when Intel SpeedStep Technology set Disabled and Intel Turbo Boost Technology set Enabled.

Intel Turbo Boost Technology

Intel Turbo Boost Technology enables the processor to run above its base operating frequency when the operating system requests the highest performance state.

Intel Speed Shift Technology

Enable/Disable Intel Speed Shift Technology support. Enabling will expose the CPPC v2 interface to allow for hardware controlled P-states.

To Get best support for Intel Turbo Boost Max Technology 3.0 (ITBMT 3.0), you have to enable Intel Speed Shift Technology. If your CPU does not support ITBMT 3.0, option will still grayed out.

Intel Turbo Boost Max Technology 3.0

Enable/Disable Intel Turbo Boost Technology 3.0 (ITBMT 3.0) support. Disabling will report the maximum ratio of the slowest core in `_CPC` object. Processors supportinh the ITBMT 3.0 feature contain at least on processor core whose maximum ratio is higher than the others.

Intel Thermal Velocity Boost Voltage Optimizations

This service controls thermal based voltage optimizations for processors that implement the Intel Thermal Velocity Boost (TVB) feature.

TVB Information

Enter this item to view TVB information.

CPU Tj Max

Set CPU Tj Max to adjust TCC Target Temperature. Support TjMax in the range of 62 to 115 deg Celsius.

Dual Tau Boost

Enable Dual Tau Boost feature for 35W/65W/125W CPU to achieve performance boost with additional PL1 greater than TDP for limited durations

Load Intel Base Power Limit Settings

Enable/Disable Load Intel Base Power Limit Settings. When enabled, the power limit and current limit will use Intel Base Power Limit Settings.

Long Duration Power Limit

Configure Package Power Limit 1 in watts. When the limit is exceeded, the CPU ratio will be lowered after a period of time. A lower limit can protect the CPU and save power, while a higher limit may improve performance.

Long Duration Maintained

Configure the period of time until the CPU ratio is lowered when the Long Duration Power Limit is exceeded.

Short Duration Power Limit

Configure Package Power Limit 2 in watts. When the limit is exceeded, the CPU ratio will be lowered immediately. A lower limit can protect the CPU and save power, while a higher limit may improve performance.

CPU Core Unlimited Current Limit

To unlock voltage regulator current limit completely, you can set this option to Enabled.

CPU Core Current Limit

Configure the Voltage Regulator Current Limit. This value represents the Maximum instantaneous current allowed at any given time.

GT Unlimited Current Limit

To unlock voltage regulator current limit completely, you can set this option to Enabled.

GT Current Limit

Configure the Voltage Regulator Current Limit. This value represents the Maximum instantaneous current allowed at any given time.

3.3.2 DRAM Configuration

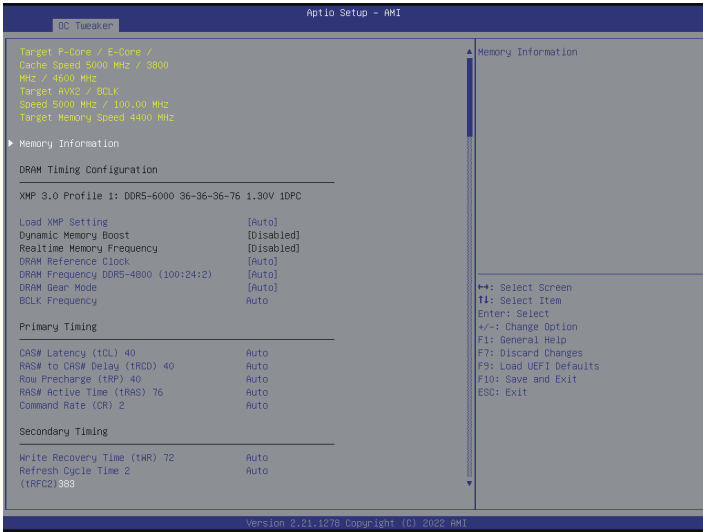

Memory Information

Allows users to browse the serial presence detect (SPD) and Intel extreme memory profile (XMP) for DDR modules.

DRAM Timing Configuration

Load XMP Setting

Load XMP settings to overclock the DDR memory and perform beyond standard specifications.

DRAM Reference Clock

Select Auto for optimized settings.

DRAM Frequency

If [Auto] is selected, the motherboard will detect the memory module(s) inserted and assign the appropriate frequency automatically.

DRAM Gear Mode

High gear is good for high frequency.

BCLK Frequency

The CPU speed is determined by the CPU Ratio multiplied with the BCLK. Increasing the BCLK will increase the internal CPU clock speed but also affect the clock speed of other components.

Primary Timing

CAS# Latency (tCL)

The time between sending a column address to the memory and the beginning of the data in response.

RAS# to CAS# Delay (tRCD)

The number of clock cycles required between the opening of a row of memory and accessing columns within it.

Row Precharge Time (tRP)

The number of clock cycles required between the issuing of the precharge command and opening the next row.

RAS# Active Time (tRAS)

The number of clock cycles required between a bank active command and issuing the precharge command.

Command Rate (CR)

The delay between when a memory chip is selected and when the first active command can be issued.

Secondary Timing

Write Recovery Time (tWR)

The amount of delay that must elapse after the completion of a valid write operation, before an active bank can be precharged.

Refresh Cycle Time₂ (tRFC₂)

The number of clocks from a Refresh command until the first Activate command to the same rank.

Refresh Cycle Time per Bank (tRFCpb)

The number of clocks that a per bank Refresh command takes to complete.

RAS to RAS Delay (tRRD_L)

The number of clocks between two rows activated in different banks of the same rank.

RAS to RAS Delay (tRRD_S)

The number of clocks between two rows activated in different banks of the same rank.

Write to Read Delay (tWTR_L)

The number of clocks between the last valid write operation and the next read command to the same internal bank.

Write to Read Delay (tWTR_S)

The number of clocks between the last valid write operation and the next read command to the same internal bank.

Read to Precharge (tRTP)

The number of clocks that are inserted between a read command to a row pre-charge command to the same rank.

Four Activate Window (tFAW)

The time window in which four activates are allowed the same rank.

CAS Write Latency (tCWL)

Configure CAS Write Latency.

Third Timing

tREFI

Configure refresh cycles at an average periodic interval.

tCKE

Configure the period of time the DDR4 initiates a minimum of one refresh command internally once it enters Self-Refresh mode.

tRC

Configure the minimum active to active/Refresh Time.

Turn Around Timing

Turn Around Timing Optimization

Auto is enabled in general case.

TAT Training Value

tRDRD_sg

Configure between module read to read delay.

tRDRD_dg

Configure between module read to read delay.

tRDRD_dr

Configure between module read to read delay.

tRDRD_dd

Configure between module read to read delay.

tRDWR_sg

Configure between module read to write delay.

tRDWR_dg

Configure between module read to write delay.

tRDWR_dr

Configure between module read to write delay.

tRDWR_dd

Configure between module read to write delay.

tWRRD_sg

Configure between module write to read delay.

tWRRD_dg

Configure between module write to read delay.

tWRRD_dr

Configure between module write to read delay.

tWRRD_dd

Configure between module write to read delay.

tWRWR_sg

Configure between module write to write delay.

tWRWR_dg

Configure between module write to write delay.

tWRWR_dr

Configure between module write to write delay.

tWRWR_dd

Configure between module write to write delay.

TAT Runtime Value

tRDRD_sg

Configure between module write to read delay.

tRDRD_dg

Configure between module write to read delay.

tRDRD_dr

Configure between module write to read delay.

tRDRD_dd

Configure between module write to read delay.

tRDWR_sg

Configure between module write to read delay.

tRDWR_dg

Configure between module write to read delay.

tRDWR_dr

Configure between module write to read delay.

tRDWR_dd

Configure between module write to read delay.

tWRRD_sg

Configure between module write to read delay.

tWRRD_dg

Configure between module write to read delay.

tWRRD_dr

Configure between module write to read delay.

tWRRD_dd

Configure between module write to read delay.

tWRWR_sg

Configure between module write to write delay.

tWRWR_dg

Configure between module write to write delay.

tWRWR_dr

Configure between module write to write delay.

tWRWR_dd

Configure between module write to write delay.

Round Trip Timing**Round Trip Timing Optimization**

Auto is enabled in general case.

Round Trip Level

Configure round trip level.

Initial RTL IO Delay Offset

Configure round trip latency IO delay initial offset.

Initial RTL FIFO Delay Offset

Configure round trip latency FIFO delay initial offset.

Initial RTL (MC0 C0 A1/A2)

Configure round trip latency initial value.

Initial RTL (MC0 C1 A1/A2)

Configure round trip latency initial value.

Initial RTL (MC1 C0 B1/B2)

Configure round trip latency initial value.

Initial RTL (MC1 C1 B1/B2)

Configure round trip latency initial value.

RTL (MC0 C0 A1/A2)

Configure round trip latency.

RTL (MC0 C1 A1/A2)

Configure round trip latency.

RTL (MC1 C0 B1/B2)

Configure round trip latency.

RTL (MC1 C1 B1/B2)

Configure round trip latency.

ODT Setting

Dimm ODT Training

ODT values will be optimized by Dimm On-Die Termination Training.

ODT WR (A1)

Configure the memory on die termination resistors WR.

ODT WR (A2)

Configure the memory on die termination resistors WR.

ODT WR (B1)

Configure the memory on die termination resistors WR.

ODT WR (B2)

Configure the memory on die termination resistors WR.

ODT NOM Rd (A1)

Configure the memory on die termination resistors NOM Rd.

ODT NOM Rd (A2)

Configure the memory on die termination resistors NOM Rd.

ODT NOM Rd (B1)

Configure the memory on die termination resistors NOM Rd.

ODT NOM Rd (B2)

Configure the memory on die termination resistors NOM Rd.

ODT PARK (A1)

Configure the memory on die termination resistors PARK.

ODT PARK (A2)

Configure the memory on die termination resistors PARK.

ODT PARK (B1)

Configure the memory on die termination resistors PARK.

ODT PARK (B2)

Configure the memory on die termination resistors PARK.

ODT PARK DQS (A1)

Configure the memory on die termination resistors PARK DQS.

ODT PARK DQS (A2)

Configure the memory on die termination resistors PARK DQS.

ODT PARK DQS (B1)

Configure the memory on die termination resistors PARK DQS.

ODT PARK DQS (B2)

Configure the memory on die termination resistors PARK DQS.

ODT CA (A1 Group A)

Configure the memory on die termination resistors ODT CA.

ODT CA (A2 Group A)

Configure the memory on die termination resistors ODT CA.

ODT CA (B1 Group A)

Configure the memory on die termination resistors ODT CA.

ODT CA (B2 Group A)

Configure the memory on die termination resistors ODT CA.

ODT CA (A1 Group B)

Configure the memory on die termination resistors ODT CA.

ODT CA (A2 Group B)

Configure the memory on die termination resistors ODT CA.

ODT CA (B1 Group B)

Configure the memory on die termination resistors ODT CA.

ODT CA (B2 Group B)

Configure the memory on die termination resistors ODT CA.

ODT CS (A1 Group A)

Configure the memory on die termination resistors ODT CS.

ODT CS (A2 Gruop A)

Configure the memory on die termination resistors ODT CS.

ODT CS (B1 Gruop A)

Configure the memory on die termination resistors ODT CS.

ODT CA (B2 Gruop A)

Configure the memory on die termination resistors ODT CS.

ODT CS (A1 Gruop B)

Configure the memory on die termination resistors ODT CS.

ODT CS (A2 Gruop B)

Configure the memory on die termination resistors ODT CS.

ODT CS (B1 Gruop B)

Configure the memory on die termination resistors ODT CS.

ODT CS (B2 Gruop B)

Configure the memory on die termination resistors ODT CS.

ODT CK (A1 Gruop A)

Configure the memory on die termination resistors ODT CK.

ODT CK (A2 Gruop A)

Configure the memory on die termination resistors ODT CK.

ODT CK (B1 Gruop A)

Configure the memory on die termination resistors ODT CK.

ODT CK (B2 Gruop A)

Configure the memory on die termination resistors ODT CK.

ODT CK (A1 Gruop B)

Configure the memory on die termination resistors ODT CK.

ODT CK (A2 Group B)

Configure the memory on die termination resistors ODT CK.

ODT CK (B1 Group B)

Configure the memory on die termination resistors ODT CK.

ODT CK (B2 Group B)

Configure the memory on die termination resistors ODT CK.

Advanced Setting

ASRock Timing Optimization

Enable/Disable ASRock Timing Optimization. When Enabled, the memory timing will use ASRock optimized value.

ASRock DRAM Frequency Optimization

Enable/Disable ASRock DRAM Frequency Optimization. When Enabled, the DRAM Frequency will use ASRock optimized procedure.

MRC Training Respond Time

Configure the MRC Training Respond Time.

Realtime Memory Timing

Configure the realtime memory timings.

[Enabled] The system will allow performing realtime memory timing changes after MRC_DONE.

Reset for MRC Failed

Reset system after MRC training is failed.

3.3.3 Voltage Configuration

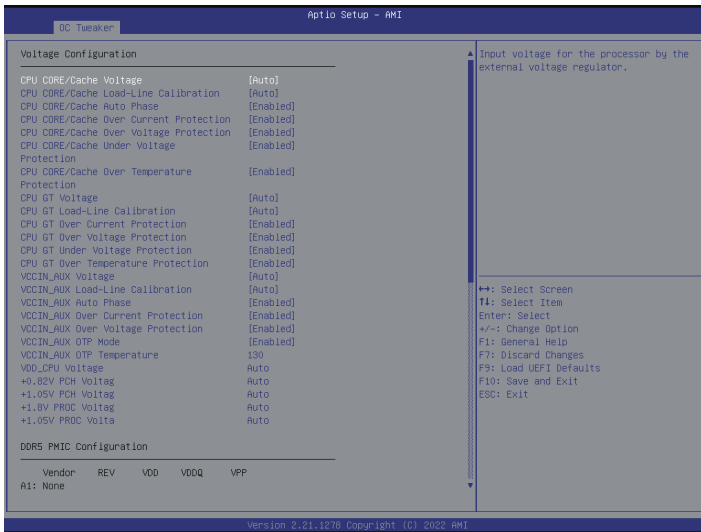

CPU Core/Cache Voltage

Input voltage for the processor by the external voltage regulator.

CPU Core/Cache Load-Line Calibration

CPU Core/Cache Load-Line Calibration helps prevent CPU Core/Cache voltage droop when the system is under heavy loading.

CPU Core/Cache Auto Phase

Configure CPU CORE/Cache Auto Phase

CPU CORE/Cache Over Current Protection

Configure CPU CORE/Cache Over Current Protection

CPU CORE/Cache Over Voltage Protection

Configure CPU CORE/Cache Over Voltage Protection.

CPU CORE/Cache Under Voltage Protection

Configure CPU CORE/Cache Under Voltage Protection.

CPU CORE/Cache Over Temperature Protection

Configure CPU CORE/Cache Over Temperature Protection.

CPU GT Voltage

Configure the voltage for the integrated GPU.

CPU GT Load-Line Calibration

GT Load-Line Calibration helps prevent integrated GPU voltage droop when the system is under heavy load.

GPU GT Over Current Protection

Configure CPU GT Over Current Protection.

GPU GT Over Voltage Protection

Configure CPU GT Over Voltage Protection.

GPU GT Under Voltage Protection

Configure CPU GT Under Voltage Protection.

GPU GT Over Temperature Protection

Configure CPU GT Over Temperature Protection.

VCCIN_AUX Voltage

Input voltage for the processor by the external voltage regulator.

VCCIN_AUX Load-Line Calibration

VCCIN_AUX Load-Line Calibration helps prevent VCCIN_AUX voltage droop when the system is under heavy loading.

VCCIN_AUX Phase

Configure VCCIN_AUX Auto Phase

VCCIN_AUX Over Current Protection

Configure VCCIN_AUX Over Current Protection

VCCIN_AUX Over Voltage Protection

Configure VCCIN_AUX Over Voltage Protection.

VCCIN_AUX OTP Mode

Configure VCCIN_AUX OTP Mode

VCCIN_AUX OTP Temperature

Configure VCCIN_AUX OTP Temperature

VDD_CPU Voltage

Configure the voltage for the VDD_CPU.

+0.82V PCH Voltage

Configure the voltage for the +0.82V PCH.

+1.05 PCH Voltage

Configure the voltage for the +1.05 PCH.

+1.8V PROC Voltage

Configure the voltage for the +1.8V PROC.

+1.05V PROC Voltage

Configure the voltage for the +1.05V PROC.

DRR5 PMIC Configuration

PMIC Voltage Option

Choose separate to individually adjust DIMM PMIC.

VDD Voltage

Configure the memory VDD Voltage

VDD Voltage Range

Configure the memory VDD Voltage Range.

VDDQ Voltage

Configure the memory VDDQ Voltage

VDDQ Voltage Range

Configure the memory VDDQ Voltage Range.

VPP Voltage

Configure the memory VPP Voltage

VDD Eventual Voltage

Configure the memory VDD Eventual Voltage

VDDQ Eventual Voltage

Configure the memory VDDQ Eventual Voltage

VPP Eventual Voltage

Configure the memory VPP Eventual Voltage

PMIC Protection Unlock

Configure the PMIC Protection Unlock setting.

PLL Voltage Configuration

P-Core PLL Voltage offset

PLL Voltage offset ranges from 0 to 15 bins, each bin is 15mV. Adding 5 or more bins will help to increase the range of this domain frequency in extreme overclocking conditions. The best bins will be different on each processor, user has to find the best bins for your own processor.

E-Core PLL Voltage offset

PLL Voltage offset ranges from 0 to 15 bins, each bin is 15mV. Adding 5 or more bins will help to increase the range of this domain frequency in extreme overclocking conditions. The best bins will be different on each processor, user has to find the best bins for your own processor.

Ring PLL Voltage offset

PLL Voltage offset ranges from 0 to 15 bins, each bin is 15mV. Adding 5 or more bins will help to increase the range of this domain frequency in extreme overclocking conditions. The best bins will be different on each processor, user has to find the best bins for your own processor.

System Agent PLL Voltage offset

PLL Voltage offset ranges from 0 to 15 bins, each bin is 15mV. Adding 5 or more bins will help to increase the range of this domain frequency in extreme overclocking conditions. The best bins will be different on each processor, user has to find the best bins for your own processor.

Memory Controller PLL Voltage offset

PLL Voltage offset ranges from 0 to 15 bins, each bin is 15mV. Adding 5 or more bins will help to increase the range of this domain frequency in extreme overclocking conditions. The best bins will be different on each processor, user has to find the best bins for your own processor.

GT PLL Voltage offset

PLL Voltage offset ranges from 0 to 15 bins, each bin is 15mV. Adding 5 or more bins will help to increase the range of this domain frequency in extreme overclocking conditions. The best bins will be different on each processor, user has to find the best bins for your own processor.

AVX Configuration

AVX2 Voltage Guardband Scale Factor

AVX2 Voltage Guardband Scale Factor controls the voltage guardband applied to AVX2 workloads. A value > 1.00 will increase the voltage guardband, and < 1.00 will decrease the voltage guardband.

3.4 Advanced Screen

In this section, you may set the configurations for the following items: CPU Configuration, Chipset Configuration, PCH-FW Configuration, Storage Configuration, NVMe Configuration, ACPI Configuration, USB Configuration, Super IO Configuration, Serial Port Console Redirection, H/W Monitor, Trusted Computing, Intel ME Configuration, Network Stack Configuration, VMD Configuration, Driver Health and Insant Flash.

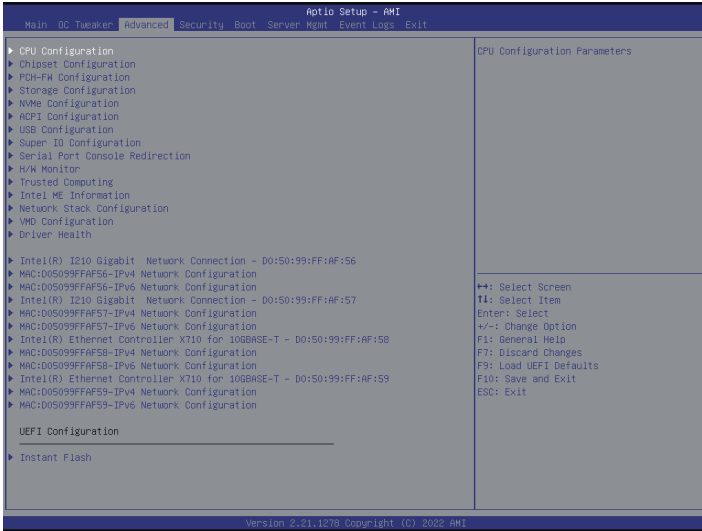

Setting wrong values in this section may cause the system to malfunction.

3.4.1 CPU Configuration



Processor P-Core Information

This item displays the P-Core Information.

Processor E-Core Information

This item displays the E-Core Information.

Intel Hyper Threading Technology

Intel Hyper Threading Technology allows multiple threads to run on each core, so that the overall performance on threaded software is improved.

Pre-Core Hyper Threading

The Pre-Core Hyper Threading feature allows you to disable Hyper Threading on specific cores.

Active Processor P-Cores

Select the number of cores to enable in each processor package.

Active Processor E-Cores

Select the number of E-Cores to enable in each processor package.

CPU C States Support

Enable CPU C States Support for power saving. It is recommended to keep C6 and C7 enabled for better power saving.

Enhanced Halt State (C1E)

Enable Enhanced Halt State (C1E) for lower power consumption.

CPU C6 State Support

Enable C6 deep sleep state for lower power consumption.

CPU C7 State Support

Enable C7 deep sleep state for lower power consumption.

Package C State Support

Enable CPU, PCIe, Memory, Graphics C State Support for power saving.

CFG Lock

This item allows you to disable or enable the CFG Lock.

C6DRAM

Enable/Disable moving of DRAM contents to PRM memory when CPU is in C6 state.

CPU Thermal Throttling

Enable CPU internal thermal control mechanisms to keep the CPU from overheating.

Intel AVX/AVX2

Enable/Disable the Intel AVX and AVX2 Instructions. This is applicable for Big Core only.

Intel AVX-512

Enable/Disable the Intel AVX-512 (a.k.a. AVX3) Instructions. This is applicable for Big Core only.

Intel Virtualization Technology

Intel Virtualization Technology allows a platform to run multiple operating systems and applications in independent partitions, so that one computer system can function as multiple virtual systems.

Hardware Prefetcher

Automatically prefetch data and code for the processor. Enable for better performance.

Adjacent Cache Line Prefetch

Automatically prefetch the subsequent cache line while retrieving the currently requested cache line. Enable for better performance.

Legacy Game Compatibility Mode

When enabled, pressing the scroll lock key will toggle the Efficient cores between being parked when Scroll Lock LED is on and un-parked when LED is off.

3.4.2 Storage Configuration

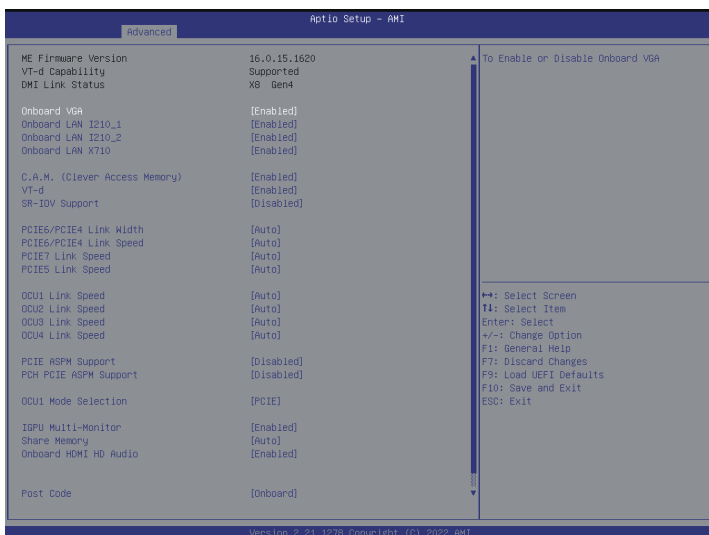

Onboard VGA

To enable or Disable Onboard VGA.

Onboard LAN I210_1

To enable or Disable Onboard LAN.

Onboard LAN I210_2

To enable or Disable Onboard LAN.

Onboard LAN X710 *(for Z690D4U-2L2TG5 / W680D4U-2L2T/G5 only)*

To enable or Disable Onboard LAN.

Onboard BCM57416 *(for Z690D4U-2L2TG5/BCM / W680D4U-2L2T/G5/BCM only)*

To enable or Disable Onboard LAN.

C.A.M (Clever Access Memory)

If system has Resizable BAR capable PCIe Devices, use this option to enable or disable Resizable BAR support (only of the system supports 64 bit PCI decoding).

VT-d

Intel® Virtualization Technology for Directed I/O helps your virtual machine monitor better utilize hardware by improving application compatibility and reliability, and providing additional levels of manageability, security, isolation, and I/O performance.

SR-IOV Support

If system has SR-IOV capable PCIe Devices, this option Enables or Disables Single Root IO Virtualization Support.

PCIe6/PCIe4 Link Width

Configure PCIe Slot Link Width.

PCIe6/PCIe4 Link Speed

Configure PCIe9/PCIe4 Slot Link Speed. Auto mode is optimizing for overclocking.

PCIe7 Link Speed

Configure PCIe7 Slot Link Speed. Auto mode is optimizing for overclocking.

OCU1 Link Speed

Configure OCU Slot Link Speed. Auto mode is optimizing for overclocking.

OCU2 Link Speed

Configure OCU Slot Link Speed. Auto mode is optimizing for overclocking.

OCU3 Link Speed

Configure OCU Slot Link Speed. Auto mode is optimizing for overclocking.

OCU4 Link Speed

Configure OCU Slot Link Speed. Auto mode is optimizing for overclocking.

PCIe ASPM Support

This option enables/disables the ASPM support for all CPU downstream devices.

PCH PCIe ASPM Support

This option enables/disables the ASPM support for all PCH PCIe devices.

OCU1 Mode Selection

Switch the COUlink to PCIE/SATA.

IGPU Multi-Monitor

Select disable to disable the integrated graphics when an external graphics card is installed.
Select enable to keep the integrated graphics enabled at all times.

Share Memory

Configure the size of memory that is allocated to the integrated graphics processor when the system boots up.

Onboard HDMI HD Audio

Enable audio for the onboard digital outputs.

Post Code

Display Post Code in Onboard/BMC Post Snoop.

Onboard Debug Port LED

Enable/disable the onboard Dr. Debug LED.

3.4.3 PCH-FW Configuration



Intel(R) Platform Trust Technology

Enable/disable Intel PTT in ME. Disable this option to use discrete TPM Module.

3.4.4 Storage Configuration

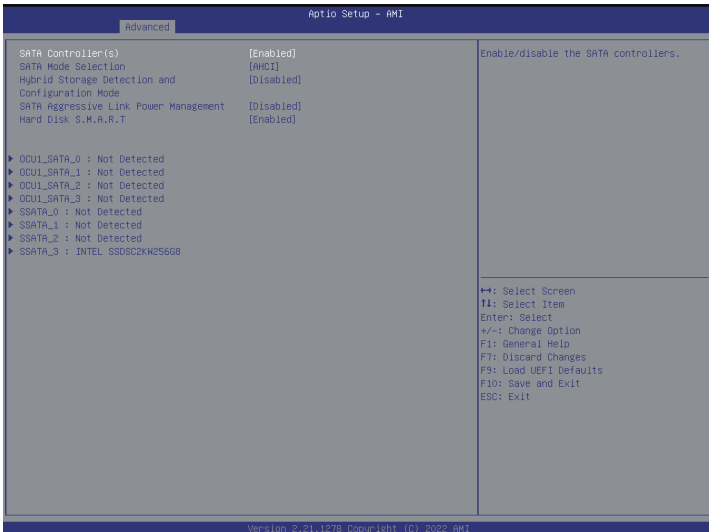

SATA Controller(s)

Enable/disable the SATA controllers.

SATA Mode Selection

AHCI: Supports new features that improve performance.

RAID: Combine multiple disk drives into a logical unit.

Hybrid Storage Detection and Configuration Mode

This item allows you select Hybrid Storage Detection and Configuration Mode.

SATA Aggressive Link Power Management

SATA Aggressive Link Power Management allows SATA devices to enter a low power state during periods of inactivity to save power. It is only supported by AHCI mode.

Hard Disk S.M.A.R.T.

S.M.A.R.T stands for Self-Monitoring, Analysis, and Reporting Technology. It is a monitoring system for computer hard disk drives to detect and report on various indicators of reliability.

3.4.5 NVMe Configuration

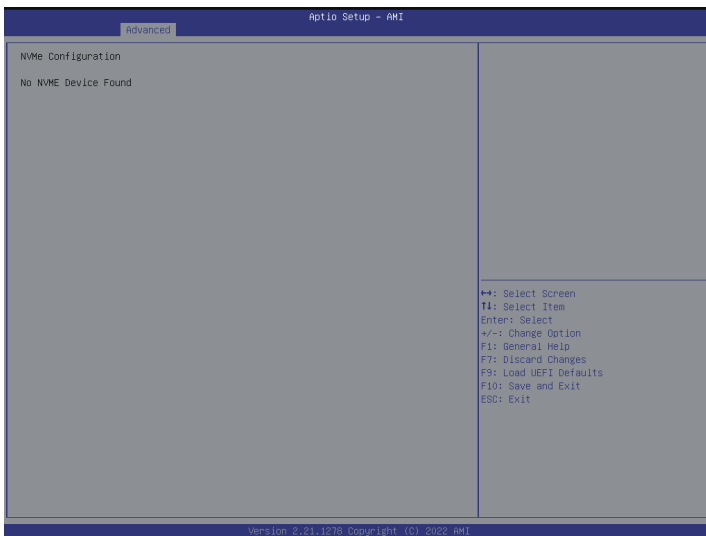

The NVMe Configuration displays the NVMe controller and Drive information.

3.4.6 ACPI Configuration

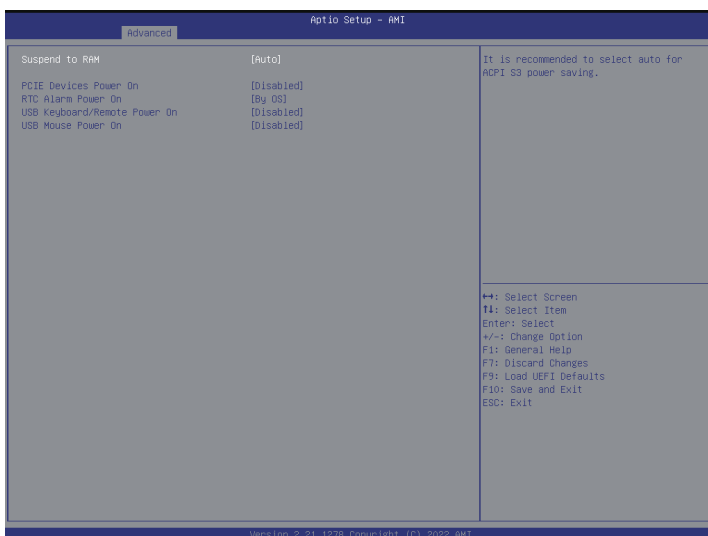

Suspend to RAM

Select disable for ACPI suspend type S1. It is recommended to select auto for ACPI S3 power saving.

PCIe Devices Power On

Allow the system to be waked up by a PCIe device and enable wake on LAN.

RTC Alarm Power On

Allow the system to be waked up by the real time clock alarm. Set it to By OS to let it be handled by your operating system.

USB Keyboard/Remote Power On

Allow the system to be waked up by an USB keyboard or remote controller.

USB Mouse Power On

Allow the system to be waked up by an USB mouse.

3.4.7 USB Configuration

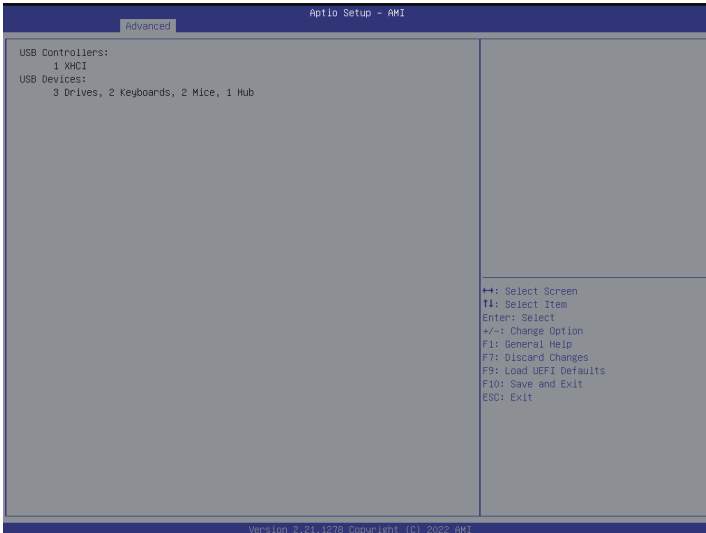

This page displays the information of the USB controllers and USB devices.

3.4.8 Super IO Configuration

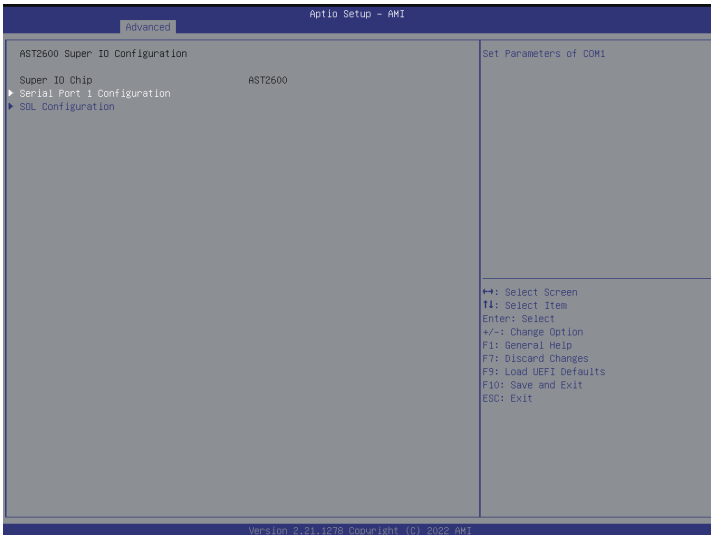

Serial Port 1 Configuration / SOL Configuration

Use this item to set parameters of COM.

Serial Port

Use this item to enable or disable the serial port (COM).

Change Settings

Use this item to select an optimal setting for Super IO device.

SOL Port Configuration

Use this item to set parameters of SOL.

Serial Port

Use this item to enable or disable the SOL port.

Change Settings

Use this item to select an optimal setting for Super IO device.

3.4.9 Serial Port Console Redirection

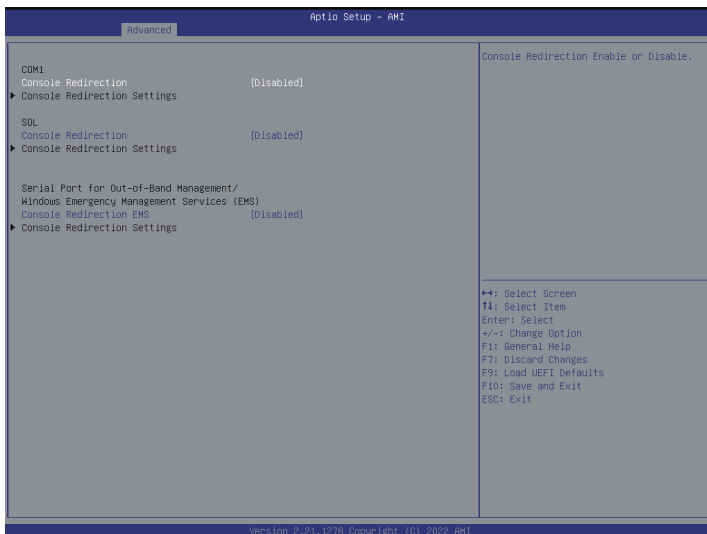

COM1 / SOL

Console Redirection

Use this option to enable or disable Console Redirection. If this item is set to Enabled, you can select a COM Port to be used for Console Redirection.

Console Redirection Settings

Use this option to configure Console Redirection Settings, and specify how your computer and the host computer to which you are connected exchange information.

Terminal Type

Use this item to select the preferred terminal emulation type for out-of-band management. It is recommended to select [VT-UTF8].

Option	Description
VT100	ASCII character set
VT100+	Extended VT100 that supports color and function keys
VT-UTF8	UTF8 encoding is used to map Unicode chars onto 1 or more bytes
ANSI	Extended ASCII character set

Bits Per Second

Use this item to select the serial port transmission speed. The speed used in the host computer and the client computer must be the same. Long or noisy lines may require lower transmission speed. The options include [9600], [19200], [38400], [57600] and [115200].

Data Bits

Use this item to set the data transmission size. The options include [7] and [8] (Bits).

Parity

Use this item to select the parity bit. The options include [None], [Even], [Odd], [Mark] and [Space]. A parity bit can be sent with the data bits to detect some transmission errors. Mark and Space Parity do not allow for error detection. They can be used as an additional data bit.

Even: parity bit is 0 if the num of 1's in the data bits is even.

Odd: parity bit is 0 if num of 1's in the data bits is odd.

Mark: parity bit is always 1.

Space: Parity bit is always 0.

Stop Bits

The item indicates the end of a serial data packet. The standard setting is [1] Stop Bit. Select [2] Stop Bits for slower devices.

Flow Control

Use this item to set the flow control to prevent data loss from buffer overflow. When sending data, if the receiving buffers are full, a "stop" signal can be sent to stop the data flow. Once the buffers are empty, a "start" signal can be sent to restart the flow. Hardware flow uses two wires to send start/stop signals. The options include [None] and [Hardware RTS/CTS].

VT-UTF8 Combo Key Support

Use this item to enable or disable the VT-UTF8 Combo Key Support for ANSI/VT100 terminals.

Recorder Mode

Use this item to enable or disable Recorder Mode to capture terminal data and send it as text messages.

Resolution 100x31

Use this item to enable or disable extended terminal resolution support.

Putty Keypad

Use this item to select Function Key and Keypad on Putty.

Legacy Console Redirection

Legacy Console Redirection Settings

Use this option to configure Legacy Console Redirection Settings, and specify how your

computer and the host computer to which you are connected exchange information.

Redirection COM Port

Select a COM port to display redirection of Legacy OS and Legacy OPROM Messages.

Resolution

On Legacy OS, the Number of Rows and Columns supported redirection.

Redirection After BIOS POST

If the [LoadBooster] is selected, legacy console redirection is disabled before booting to legacy OS. If [Always Enabled] is selected, legacy console redirection is enabled for legacy OS. The default value is [Always Enabled].

Serial Port for Out-of-Band Management/Windows Emergency Management Services (EMS)

Console Redirection

Use this option to enable or disable Console Redirection. If this item is set to Enabled, you can select a COM Port to be used for Console Redirection.

Console Redirection Settings

Use this option to configure Console Redirection Settings, and specify how your computer and the host computer to which you are connected exchange information.

Out-of-Band Mgmt Port

Microsoft Windows Emergency Management Services (EMS) allows for remote management of a Windows Server OS through a serial port.

Terminal Type EMS

Use this item to select the preferred terminal emulation type for out-of-band management. It is recommended to select [VT-UTF8].

Option	Description
VT100	ASCII character set
VT100+	Extended VT100 that supports color and function keys
VT-UTF8	UTF8 encoding is used to map Unicode chars onto 1 or more bytes
ANSI	Extended ASCII character set

Bits Per Second EMS

Use this item to select the serial port transmission speed. The speed used in the host computer and the client computer must be the same. Long or noisy lines may require lower transmission speed. The options include [9600], [19200], [57600] and [115200].

Flow Control EMS

Use this item to set the flow control to prevent data loss from buffer overflow. When sending data, if the receiving buffers are full, a "stop" signal can be sent to stop the data

flow. Once the buffers are empty, a "start" signal can be sent to restart the flow. Hardware flow uses two wires to send start/stop signals. The options include [None], [Hardware RTS/CTS], and [Software Xon/Xoff].

Data Bits EMS

Parity EMS

Stop Bits EMS

3.4.10 H/W Monitor

In this section, it allows you to monitor the status of the hardware on your system, including the parameters of the CPU temperature, motherboard temperature, CPU fan speed, chassis fan speed, and the critical voltage.

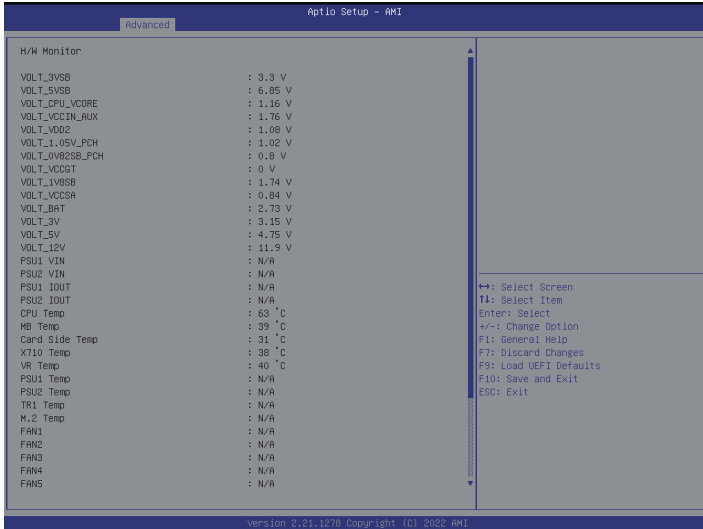

Watch Dog Timer

This allows you to enable or disable the Watch Dog Timer. The default value is [Disabled].

3.4.11 Trusted Computing

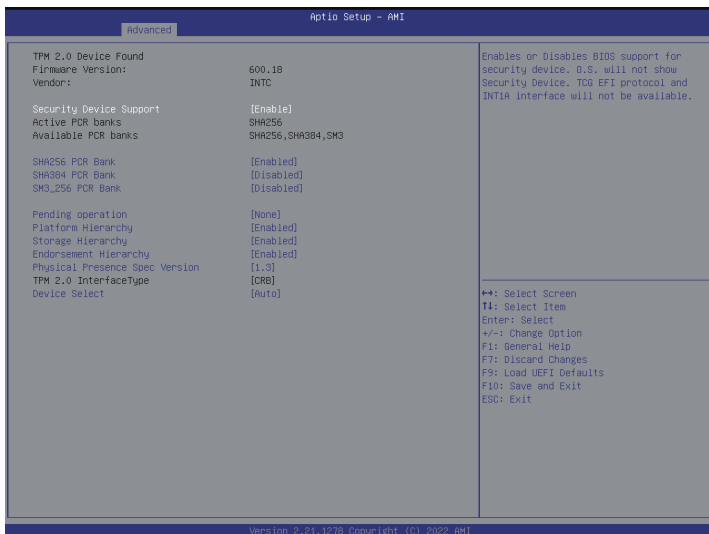

NOTE: Options vary depending on the version of your connected TPM module.

Security Device Support

Enable to activate Trusted Platform Module (TPM) security for your hard diskdrives.

Active PCR banks

This item displays active PCR Banks.

Available PCR Banks

This item displays available PCR Banks.

SHA256 PCR Bank

Use this item to enable or disable SHA256 PCR Bank

SHA384 PCR Bank

Use this item to enable or disable SHA384 PCR Bank.

SM3_256 PCR Bank

Use this item to enable or disable SM3_256 PCR Bank.

Pending Operation

Schedule an Operation for the Security Device.

NOTE: Your computer will reboot during restart in order to change State of the Device.

Platform Hierarchy

Use this item to enable or disable Platform Hierarchy.

Storage Hierarchy

Use this item to enable or disable Storage Hierarchy.

Endorsement Hierarchy

Use this item to enable or disable Endorsement Hierarchy.

Physical Presence Spec version

Select this item to tell OS to support PPI spec version 1.2 or 1.3. Please note that some HCK tests might not support version 1.3.

TPM 2.0 InterfaceType (CRB)

Select the Communication Interface to TPM 2.0 Device

Device Select

Use this item to select the TPM device to be supported. TPM 1.2 will restrict support to TPM 1.2 devices. TPM 2.0 will restrict support to TPM 2.0 devices. Auto will support both with the default set to TPM 2.0 devices. If TPM 2.0 devices are not found, TPM 1.2 devices will be enumerated.

3.4.12 Intel ME Configuration

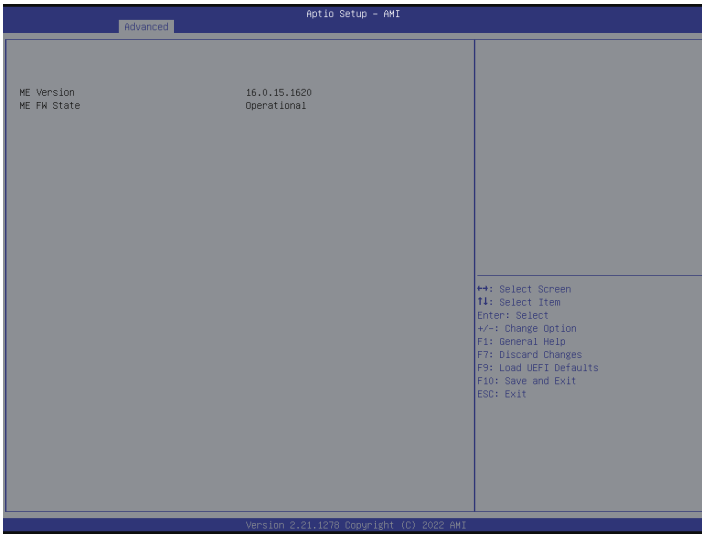

ME Subsystem screen displays the Intel ME Subsystem Configuration information, such as Operational Firmware Version, ME Firmware, ME Firmware Type, ME Firmware SKU and ME File System Integrity Value.

3.4.13 Network Stack Configuration

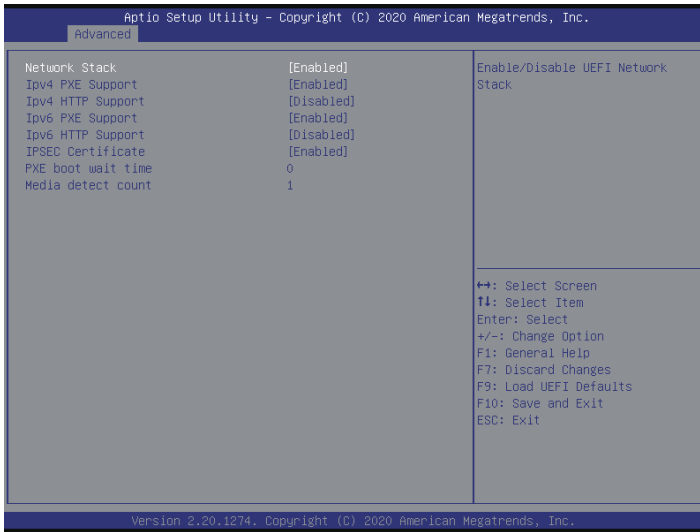

Network Stack

Use this item to enable or disable UEFI Network Stack.

Ipv4 PXE Support

Use this item to enable or disable IPv4 PXE boot support. If disabled, IPv4 PXE boot support will not be available.

Ipv4 HTTP Support

Use this item to enable or disable IPv4 HTTP boot support. If disabled, IPv4 HTTP boot support will not be available.

Ipv6 PXE Support

Use this item to enable or disable IPv6 PXE boot support. If disabled, IPv6 PXE boot support will not be available.

Ipv6 HTTP Support

Use this item to enable or disable IPv6 HTTP boot support. If disabled, IPv6 HTTP boot support will not be available.

3.4.14 VMD Configuration

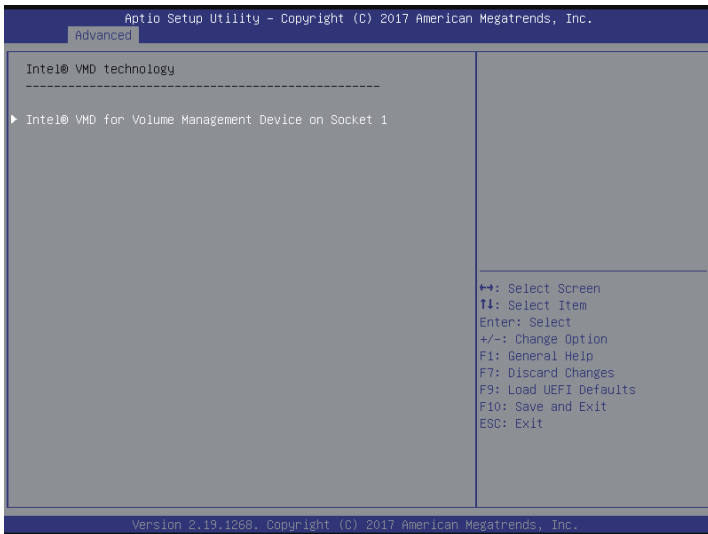

Enable VMD Controller

Use this item to enable or disable VMD Controller.

When enabled, the options below appear.

Enable VMD Global Mapping

Use this item to enable or disable VMD Global Mapping.

Map this Root Port under VMD

Use this item to map or unmap Root Port to VMD.

3.4.15 Driver Health

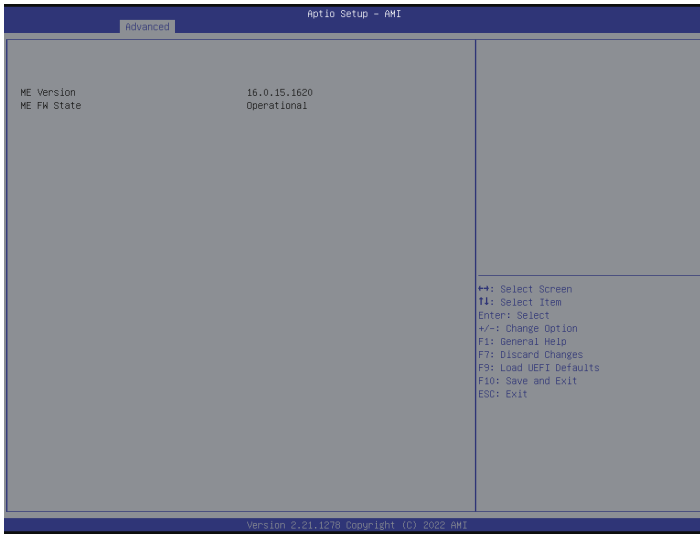

This page provides health status for the drivers/controllers.

Note: The screenshot here is for your references only. The items on this page vary depending on models and devices you use.

3.4.16 Instant Flash

Instant Flash is a UEFI flash utility embedded in Flash ROM. This convenient UEFI update tool allows you to update system UEFI without entering operating systems first like MS-DOS or Windows. Just save the new UEFI file to your USB flash drive, floppy disk or hard drive and launch this tool, then you can update your UEFI only in a few clicks without preparing an additional floppy diskette or other complicated flash utility. Please be noted that the USB flash drive or hard drive must use FAT32/16/12 file system. If you execute Instant Flash utility, the utility will show the UEFI files and their respective information. Select the proper UEFI file to update your UEFI, and reboot your system after the UEFI update process is completed.

3.5 Security Screen

In this section you may set or change the supervisor/user password for the system. You may also clear the user password.

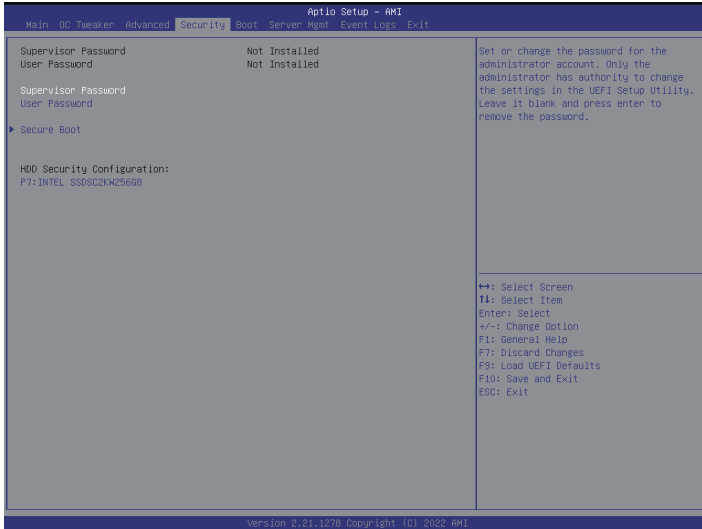

Supervisor Password

Set or change the password for the administrator account. Only the administrator has authority to change the settings in the UEFI Setup Utility. Leave it blank and press enter to remove the password.

User Password

Set or change the password for the user account. Users are unable to change the settings in the UEFI Setup Utility. Leave it blank and press enter to remove the password.

Secure Boot

Use this item to enable or disable support for Secure Boot.

Secure Boot Mode

Enable to support Windows 8 or later versions Secure Boot.

3.5.1 Key Management

In this section, expert users can modify Secure Boot Policy variables without full authentication.

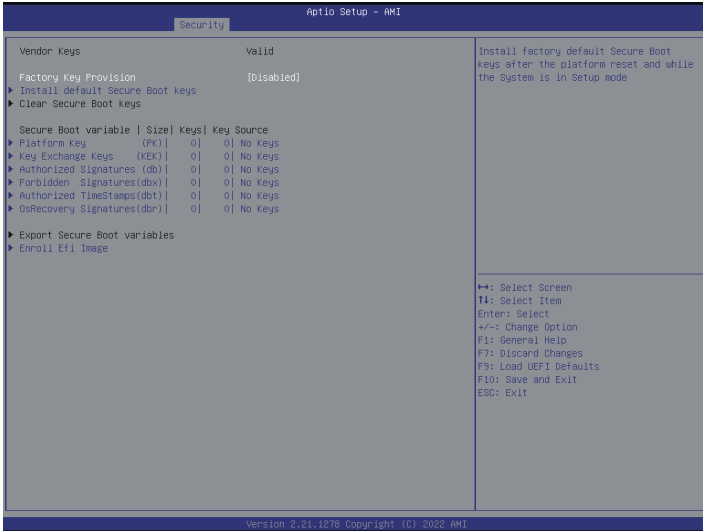

Factory Key Provision

Install factory default Secure Boot keys after the platform reset and while the System is in Setup mode.

Install Default Secure Boot Keys

Please install default secure boot keys if it's the first time you use secure boot.

Clear Secure Boot keys

Force System to Setup Mode - clear all Secure Boot Variables. Change takes effect after reboot.

Export Secure Boot variables

Copy NVRAM content of Secure Boot variables to files in a root folder on a file system device.

Enroll Efi Image

Allow the image to run in Secure Boot mode. Enroll SHA256 Hash certificate of a PE image into Authorized Signature Database (db).

3.6 Boot Screen

In this section, it will display the available devices on your system for you to configure the boot settings and the boot priority.

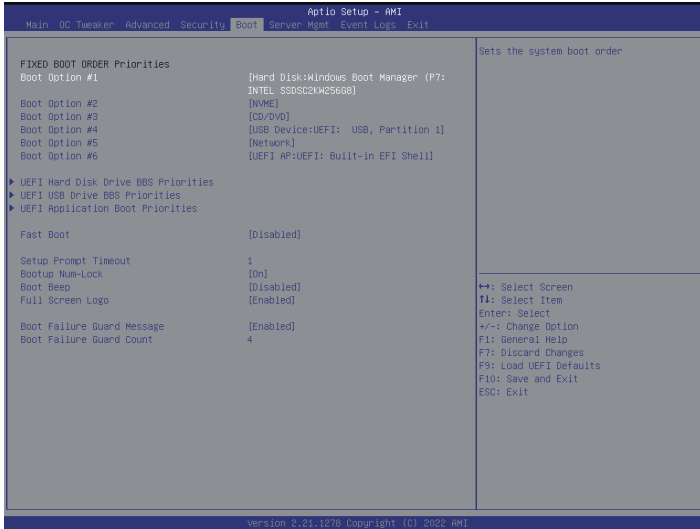

Boot Option #1~#5

Use this item to set the system boot order.

UEFI Hard Disk Drive BBS Priorities

Specifies the Boot Device Priority sequence from available UEFI Hard Disk Drives.

UEFI USB Drive BBS Priorities

Specifies the Boot Device Priority sequence from available UEFI USB Drives.

UEFI Application Boot Priorities

Specifies the Boot Device Priority sequence from available UEFI Application.

Fast Boot

Fast Boot minimizes your computer's boot time. In fast mode you may not boot from an USB storage device. Ultra Fast mode is only supported by Windows 8.1 and the VBIOS must support UEFI GOP if you are using an external graphics card. Please notice that Ultra Fast mode will boot so fast that the only way to enter this UEFI Setup Utility is to Clear CMOS or run the Restart to UEFI utility in Windows.

Setup Prompt Timeout

Configure the number of seconds to wait for the UEFI setup utility.

Bootup Num-Lock

If this item is set to [On], it will automatically activate the Numeric Lock function after boot-up.

Boot Beep

Select whether the Boot Beep should be turned on or off when the system boots up. Please note that a buzzer is needed.

Full Screen Logo

Use this item to enable or disable OEM Logo. The default value is [Enabled].

Boot Failure Guard Message

If the computer fails to boot for a number of times the system automatically restores the default settings.

Boot Failure Guard Count

Use this item to configure Boot Failure Guard Count.

3.7 Server Mgmt

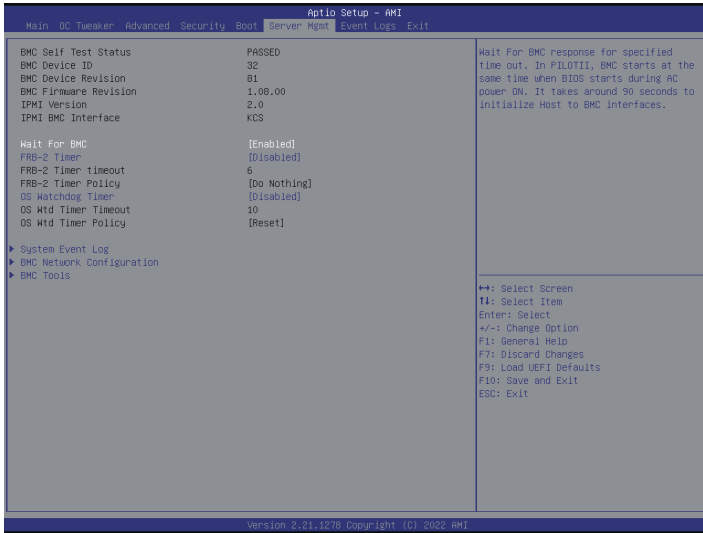

Wait For BMC

Wait For BMC response for specified time out. In PILOTII, BMC starts at the same time when BIOS starts during AC power ON. It takes around 90 seconds to initialize Host to BMC interfaces.

FRB-2 Timer

Use this item to enable or disable FRB-2 timer (POST timer).

FRB-2 Timer Timeout

Enter value between 1 to 30 min for FRB-2 Timer Expiration.

FRB-2 Timer Policy

Use this item to configure how the system should respond if the FRB-2 Timer expires. Not available if FRB-2 Timer is disabled.

OS Watchdog Timer

If enabled, starts a BIOS timer which can only be shut off by Management Software after the OS loads. Helps determine that the OS successfully loaded or follows the OS Boot Watchdog Timer policy.

3.7.1 System Event Log

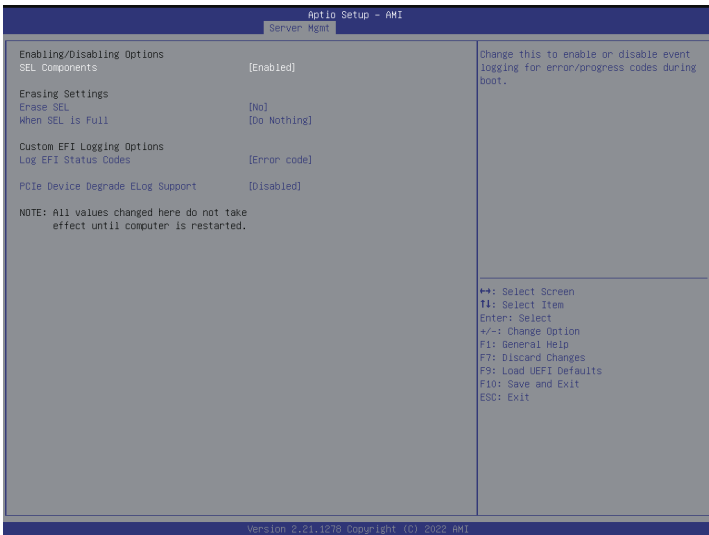

SEL Components

Change this to enable or disable all features of System Event Logging during boot.

Erase SEL

Use this to choose options for erasing SEL.

When SEL is Full

Use this to choose options for reactions to a full SEL.

Log EFI Status Codes

Use this item to disable the logging of EFI Status Codes or log only error code or only progress or both.

PCIe Device Degrade ELog Support

Use this item to enable or disable PCIe Device Degrade Error Logging Support.

3.7.2 BMC Network Configuration

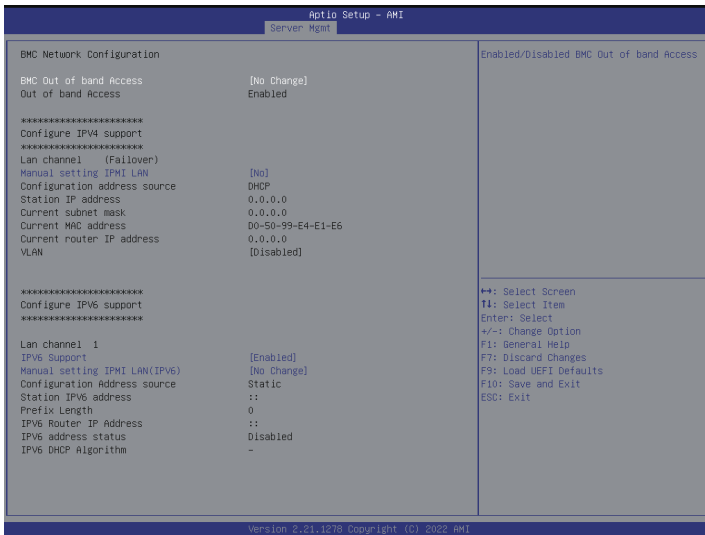

BMC Out of Band Access

Use this item to enable or disable BMC Out of Band Access.

Lan Channel (Failover)

Manual Setting IPMI LAN

If [No] is selected, the IP address is assigned by DHCP. If you prefer using a static IP address, toggle to [Yes], and the changes take effect after the system reboots. The default value is [No].

Configuration Address Source

Select to configure BMC network parameters statically or dynamically (by BIOS or BMC). Configuration options: [Static] and [DHCP].

Static: Manually enter the IP Address, Subnet Mask and Gateway Address in the BIOS for BMC LAN channel configuration.

DHCP: IP address, Subnet Mask and Gateway Address are automatically assigned by the network's DHCP server.



When [DHCP] or [Static] is selected, do NOT modify the BMC network settings on the IPMI web page.



The default login information for the IPMI web interface is:

Username: admin

Password: admin

For more instructions on how to set up remote control environment and use the IPMI management platform, please refer to the IPMI Configuration User Guide or go to the Support website at: <http://www.asrockrack.com/support/faq.asp>

VLAN

Enabled/Disabled Virtual Local Area Network.

If [Enabled] is selected, configure the items below.

IPV6 Support

Enabled/Disable LAN1 IPV6 Support.

Manual Setting IPMI LAN(IPV6)

Select to configure LAN channel parameters statically or dynamically(by BIOS or BMC).

Unspecified option will not modify any BMC network parameters during BIOS phase.

3.7.3 BMC Tools

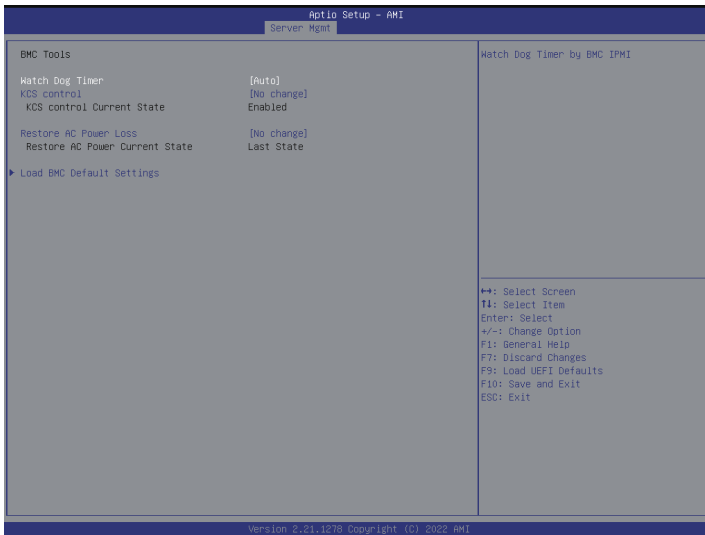

Watch Dog Timer

This item configures the Watch Dog Timer by BMC IPMI.

KCS Control

Select this KCS interface state after POST end. If [Enabled] is selected, the BMC will remain KCS interface after POST stage. If [Disabled] is selected, the BMC will disable KCS interface after POST stage.

Restore AC Power Loss

This allows you to set the power state after an unexpected AC/power loss. If [Power Off] is selected, the AC/power remains off when the power recovers. If [Power On] is selected, the AC/power resumes and the system starts to boot up when the power recovers. If [Last State] is selected, it will recover to the state before AC/power loss.

Load BMC Default Settings

Use this item to Load BMC Default Settings.

3.8 Event Logs

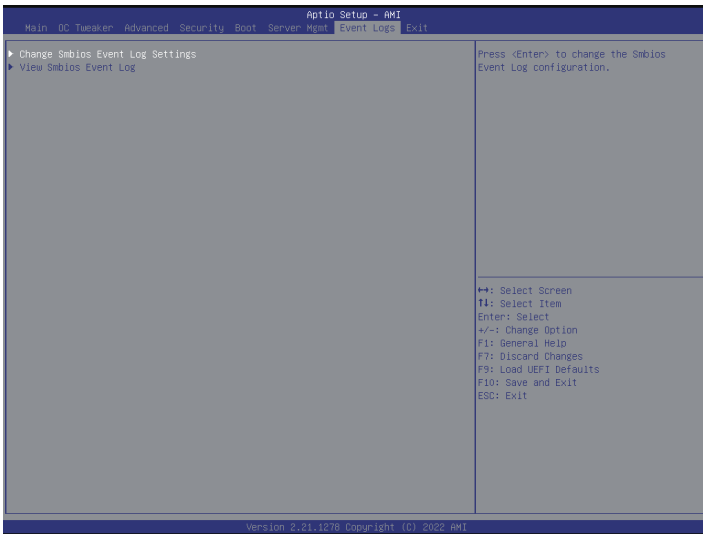

Change Smbios Event Log Settings

This allows you to configure the Smbios Event Log Settings.

When entering the item, you will see the followings:

Smbios Event Log

Use this item to enable or disable all features of the SMBIOS Event Logging during system boot.

Erase Event Log

The options include [No], [Yes, Next reset] and [Yes, Every reset]. If Yes is selected, all logged events will be erased.

When Log is Full

Use this item to choose options for reactions to a full Smbios Event Log. The options include [Do Nothing] and [Erase Immediately].

Log System Boot Event

Choose option to enable/disable logging of System boot event.

MECI (Multiple Event Count Increment)

Use this item to enter the increment value for the multiple event counter. The valid range is from 1 to 255.

METW (Multiple Event Time Window)

Use this item to specify the number of minutes which must pass between duplicate log

entries which utilize a multiple-event counter. The value ranges from 0 to 99 minutes.

View Smbios Event Log

Press <Enter> to view the Smbios Event Log records.



All values changed here do not take effect until computer is restarted.

3.9 Exit Screen

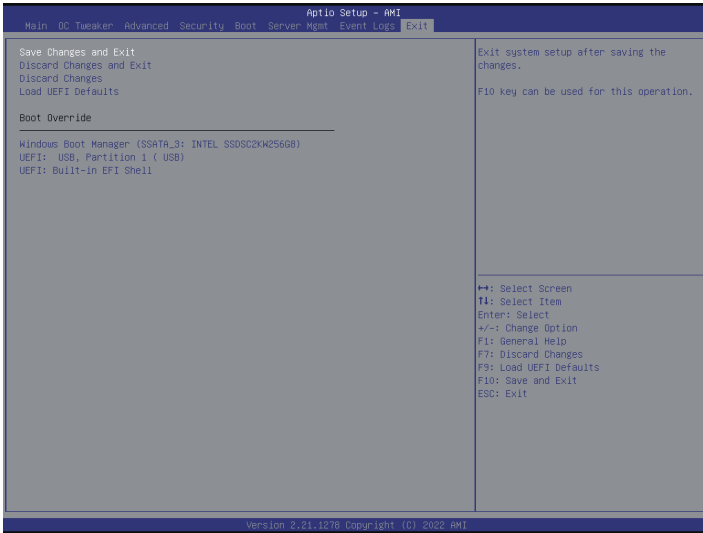

Save Changes and Exit

When you select this option, the following message “Save configuration changes and exit setup?” will pop-out. Press <F10> key or select [Yes] to save the changes and exit the UEFI SETUP UTILITY.

Discard Changes and Exit

When you select this option, the following message “Discard changes and exit setup?” will pop-out. Press <ESC> key or select [Yes] to exit the UEFI SETUP UTILITY without saving any changes.

Discard Changes

When you select this option, the following message “Discard changes?” will pop-out. Press <F7> key or select [Yes] to discard all changes.

Load UEFI Defaults

Load UEFI default values for all the setup questions. F9 key can be used for this operation.

Chapter 4 Software Support

After all the hardware has been installed, we suggest you go to our official website at <http://www.ASRockRack.com> and make sure if there are any new updates of the BIOS / BMC firmware for your motherboard.

4.1 Download and Install Operating System

This motherboard supports various Microsoft® Windows® Server / Linux compliant operating systems. Please download the operating system from your OS manufacturer. Please refer to your OS documentation for more instructions.

**Please download the Intel® Rapid Storage Technology driver from the ASRock Rack's website (www.asrockrack.com) to your USB drive while installing OS in SATA RAID mode.*

4.2 Download and Install Software Drivers

This motherboard supports various Microsoft® Windows® compliant drivers. Please download the required drivers from our website at <http://www.ASRockRack.com>.

To download necessary drivers, go to the product page, click on the "Download" tab, choose the operating system you use, and select the driver you need to be downloaded.

4.3 Contact Information

If you need to contact ASRock Rack or want to know more about ASRock Rack, welcome to visit ASRock Rack's website at <http://www.ASRockRack.com>; or you may contact your dealer for further information.

Chapter 5 Troubleshooting

5.1 Troubleshooting Procedures

Follow the procedures below to troubleshoot your system.



Always unplug the power cord before adding, removing or changing any hardware components. Failure to do so may cause physical injuries to you and damages to motherboard components.

1. Disconnect the power cable and check whether the PWR LED is off.
2. Unplug all cables, connectors and remove all add-on cards from the motherboard. Make sure that the jumpers are set to default settings.
3. Confirm that there are no short circuits between the motherboard and the chassis.
4. Install a CPU and fan on the motherboard, then connect the chassis speaker and power LED.

If there is no power...

1. Confirm that there are no short circuits between the motherboard and the chassis.
2. Make sure that the jumpers are set to default settings.
3. Check the settings of the 115V/230V switch on the power supply.
4. Verify if the battery on the motherboard provides ~3VDC. Install a new battery if it does not.

If there is no video...

1. Try replugging the monitor cables and power cord.
2. Check for memory errors.

If there are memory errors...

1. Verify that the DIMM modules are properly seated in the slots.
2. Use recommended DDR5 non-ECC UDIMMs.
3. If you have installed more than one DIMM modules, they should be identical with the same brand, speed, size and chip-type.
4. Try inserting different DIMM modules into different slots to identify faulty ones.
5. Check the settings of the 115V/230V switch on the power supply.

Unable to save system setup configurations...

1. Verify if the battery on the motherboard provides ~3VDC. Install a new battery if it does not.
2. Confirm whether your power supply provides adequate and stable power.

Other problems...

1. Try searching keywords related to your problem on ASRock Rack's FAQ page:
<http://www.asrockrack.com/support>

5.2 Technical Support Procedures

If you have tried the troubleshooting procedures mentioned above and the problems are still unsolved, please contact ASRock Rack's technical support with the following information:

1. Your contact information
2. Model name, BIOS version and problem type.
3. System configuration.
4. Problem description.

You may contact ASRock Rack's technical support at:

<http://www.asrockrack.com/support/tsd.asp>

5.3 Returning Merchandise for Service

For warranty service, the receipt or a copy of your invoice marked with the date of purchase is required. By calling your vendor or going to our RMA website (<http://event.asrockrack.com/tsd.asp>) you may obtain a Returned Merchandise Authorization (RMA) number.

The RMA number should be displayed on the outside of the shipping carton which is mailed prepaid or hand-carried when you return the motherboard to the manufacturer. Shipping and handling charges will be applied for all orders that must be mailed when service is complete.

This warranty does not cover damages incurred in shipping or from failure due to alteration, misuse, abuse or improper maintenance of products.

Contact your distributor first for any product related problems during the warranty period.

Contact Information

If you need to contact ASRock Rack or want to know more about ASRock Rack, you're welcome to visit ASRock Rack's website at <http://www.asrockrack.com>; or you may contact your dealer for further information. For technical questions, please submit a support request form at <https://event.asrockrack.com/tsd.asp>

ASRock Rack Incorporation

e-mail: ASRockRack_sales@asrockrack.com

ASRock Rack EUROPE B.V.

Bijsterhuizen 11-11
6546 AR Nijmegen
The Netherlands
Phone: +31-24-345-44-33

ASRock Rack America, Inc.

13848 Magnolia Ave, Chino, CA91710 U.S.A.
Phone: +1-909-590-8308
Fax: +1-909-590-1026