



P/N: 15G065318000AK V1.0

Quick Installation Guide
BERGAMOD8-2L2T

ASRock
Rack
www.asrockrack.com



BERGAMOD8-2L2T

The server board User's Manual is available for download from the ASRock Rack's official website at <http://www.asrockrack.com>.

Take note of the following precautions before installing server board components or change any server board settings.

1. Unplug the power cord from the wall socket before touching any components.
2. To avoid damaging the server board's components due to static electricity, NEVER place the server board directly on the carpet or the like. Also remember to use a grounded wrist strap or touch a safety grounded object before handling the components.
3. Hold components by the edges and do not touch the ICs.
4. Whenever uninstall any component, place it on a grounded anti-static pad or in the bag that comes with the component.
5. When placing screws into the screw holes to secure the server board to the chassis, please do not over-tighten the screws! Doing so may damage the server board.

1 Install the Server Board

- 1 Insert the server board into the chassis.
- 2 Affix the screws clockwise into the mounting holes in all of the corners of the server board.
Do not over-tighten the screws

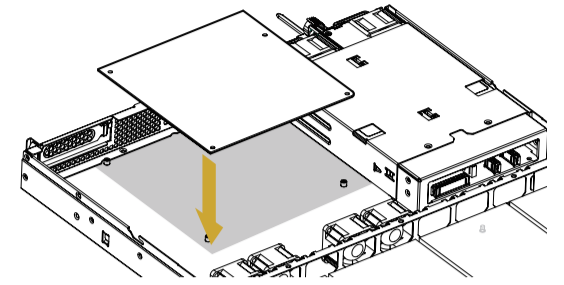

2 Motherboard Layout

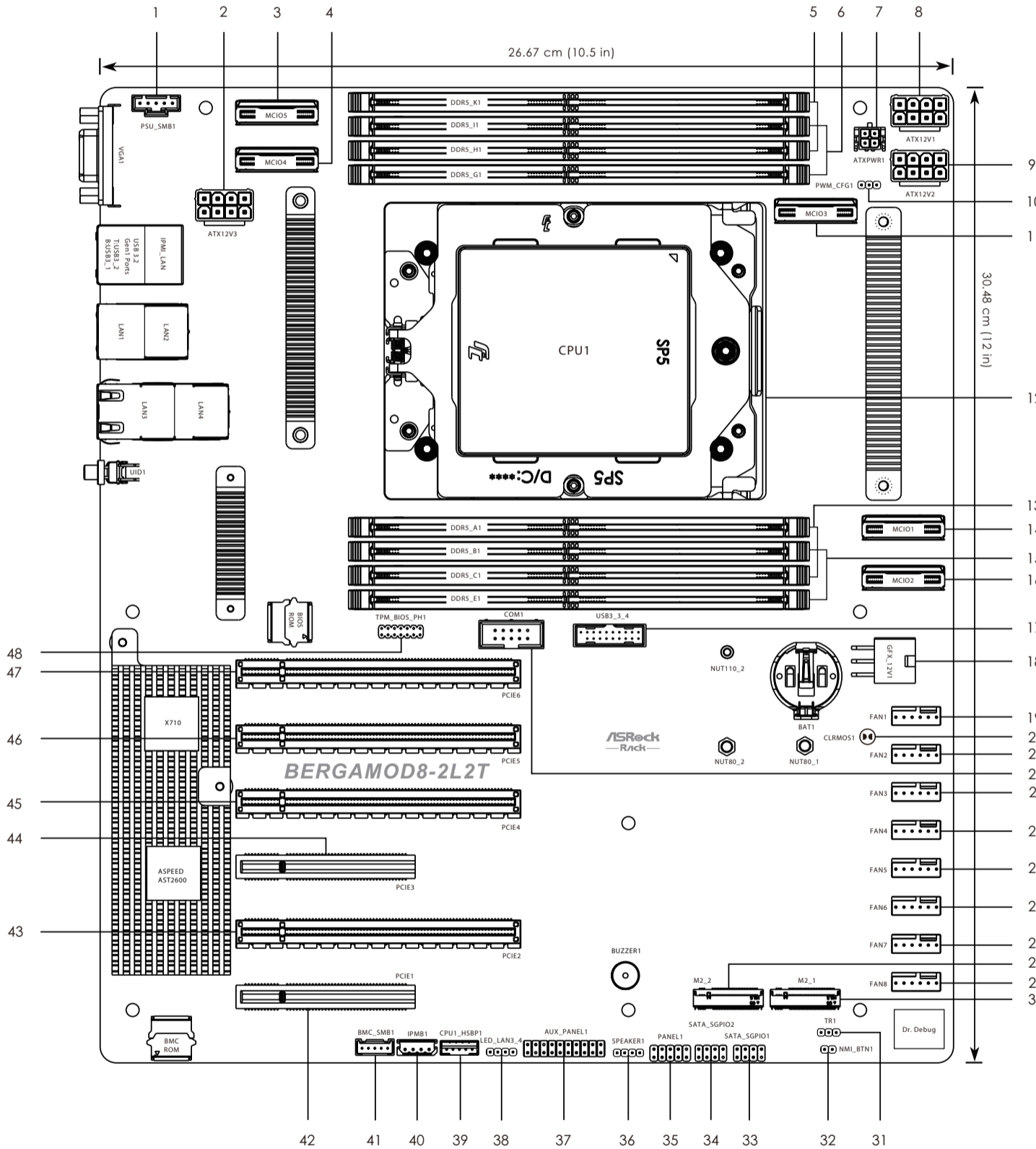

No.	Description
1	PSU SMBus Header (PSU_SMB1)
2	ATX 12V Power Connector (ATX12V3)
3	Mini Cool Edge IO x8 Connector (MCIO5)
4	Mini Cool Edge IO x8 Connector (MCIO4)
5	2 x 288-pin DDR5 DIMM Slots (DDR5_H1, DDR5_K1)
6	2 x 288-pin DDR5 DIMM Slots (DDR5_G1, DDR5_I1)
7	ATX Power Connector (ATXPWR1)
8	ATX 12V Power Connector (ATX12V1)
9	ATX 12V Power Connector (ATX12V2)
10	PWM Configuration Header (PWM_CFG1)
11	Mini Cool Edge IO x8 Connector (MCIO3)
12	AMD Socket SP5 (SM-LGA-6096P) (CPU1)
13	2 x 288-pin DDR5 DIMM Slots (DDR5_A1, DDR5_C1)
14	Mini Cool Edge IO x8 Connector (MCIO1)
15	2 x 288-pin DDR5 DIMM Slots (DDR5_B1, DDR5_E1)
16	Mini Cool Edge IO x8 Connector (MCIO2)
17	USB 3.2 Gen1 Header (USB3_3_4)
18	Graphics 12V Power Connector (GFX_12V1)
19	System Fan Connector (FAN1)
20	Clear CMOS Pad (CLRMO51)
21	System Fan Connector (FAN2)
22	COM Port Header (COM1)
23	System Fan Connector (FAN3)
24	System Fan Connector (FAN4)
25	System Fan Connector (FAN5)
26	System Fan Connector (FAN6)
27	System Fan Connector (FAN7)
28	M.2 Socket (M2_2) (Type 2280/22110)
29	System Fan Connector (FAN8)
30	M.2 Socket (M2_1) (Type 2280)
31	Thermal Sensor Header (TR1)
32	Non Maskable Interrupt Button (NMI_BTN1)
33	SATA SGPIO Connector (SATA_SGPIO1)
34	SATA SGPIO Connector (SATA_SGPIO2)
35	System Panel Header (PANEL1)
36	Speaker Header (SPEAKER1)
37	Auxiliary Panel Header (AUX_PANEL1)
38	Front LAN LED Connector (LED_LAN3_4)
39	Backplane PCI Express Hot-Plug Connector (CPU1_HSBP1)
40	Intelligent Platform Management Bus Header (IPMB1)
41	BMC SMBus Header (BMC_SMB1)
42	PCI Express 5.0 x8 Slot (PCIE1)
43	PCI Express 5.0 x16 Slot (PCIE2)
44	PCI Express 5.0 x8 Slot (PCIE3)
45	PCI Express 5.0 x16 Slot (PCIE4)
46	PCI Express 5.0 x16 Slot (PCIE5)
47	PCI Express 5.0 x16 Slot (PCIE6)
48	SPI TPM Header (TPM_BIOS_PH1)

3 I/O Panel

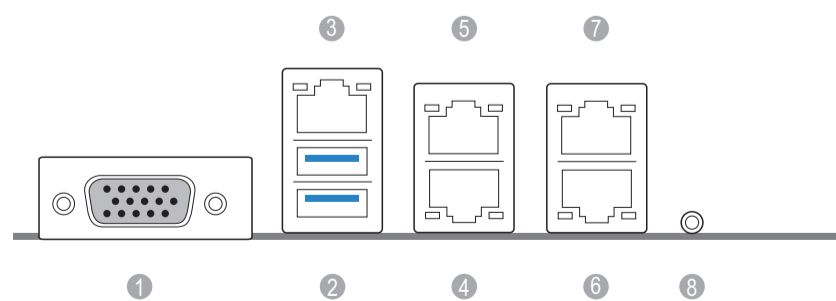

No.	Description	No.	Description
1	VGA Port (VGA1)	5	1G LAN RJ-45 Port (LAN2)
2	USB 3.2 Gen1 Ports (USB3_1_2)	6	10G LAN RJ-45 Port (LAN3)
3	IPMI LAN Header (IPMI_LAN1)	7	10G LAN RJ-45 Port (LAN4)
4	1G LAN RJ-45 Port (LAN1, shared NIC)	8	UID Switch (UID1)

4 Jumper Settings

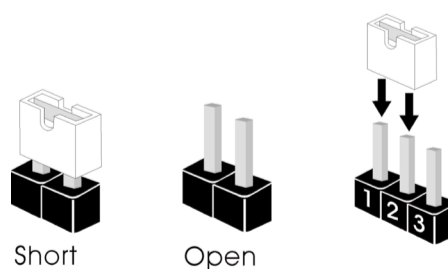

When the jumper cap is placed on the pins, the jumper is "Short". If no jumper cap is placed on the pins, the jumper is "Open".

The illustration shows a 3-pin jumper whose pin1 and pin2 are "Short" when a jumper cap is placed on these 2 pins.

5 Install the Processor and Heatsink

Locate the screw on the CPU socket and unscrew it. Open the first retention cover.

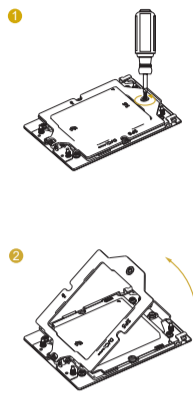

Open the second bracket. Take out the internal plastic cover.

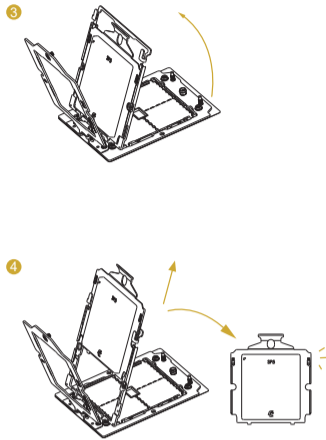

Install CPU along with the carrier frame, do not separate them. Please make sure the carrier frame with CPU is closely attached to the rail frame while inserting it.

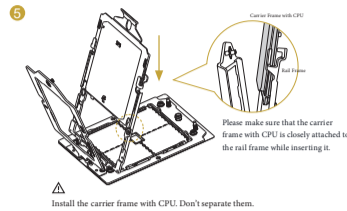

Close the bracket that holds the CPU. Close the retention cover and fasten the screw.

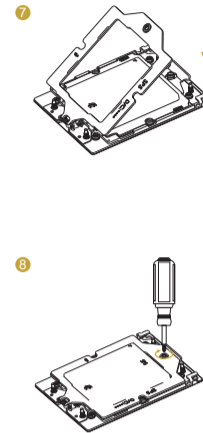

Install the heatsink to the CPU carrier. Secure the heatsink to the CPU carrier with a screwdriver.

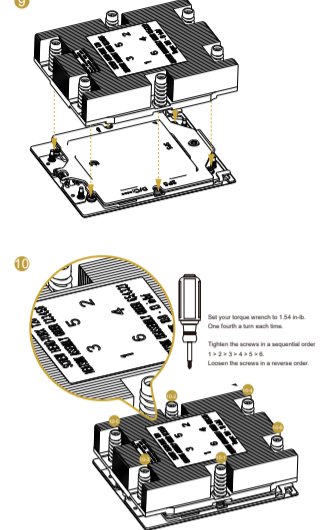

We recommend using the CPU Installation tool to avoid CPU pin-bent problem.

6 LAN Port LED Indications

IPMI LAN Port

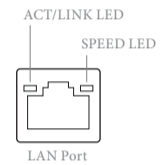

Activity / Link LED		Speed LED	
Status	Description	Status	Description
Off	No Link	Off	10Mbps connection or no link
Blinking Yellow	Data Activity	Orange	100Mbps connection
On	Link	Green	1Gbps connection

1G LAN Port

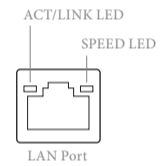

Activity / Link LED		Speed LED	
Status	Description	Status	Description
Off	No Link	Off	10Mbps connection or no link
Blinking Yellow	Data Activity	Orange	100Mbps connection
On	Link	Green	1Gbps connection

10G LAN Port

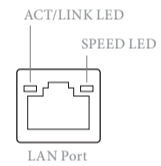

Activity / Link LED		Speed LED	
Status	Description	Status	Description
Off	No Link	Off	100Mbps connection or no link
Blinking Yellow	Data Activity	Orange	1Gbps connection
On	Link	Green	10Gbps connection

7 Install the Power Cables

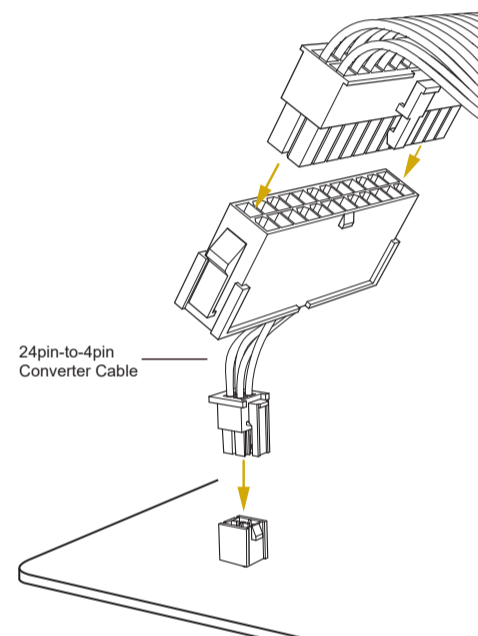

ATX12V

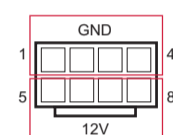

ATX4PIN1

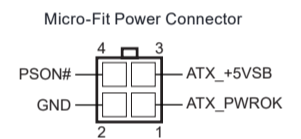

Graphics Power

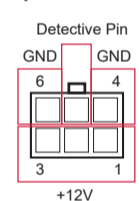

8 Install the PCIE Card

- Remove the bracket facing the slot that intending to use. Keep the screw for later use.
- Align the card connector with the slot and press firmly until the card is completely seated on the slot.
- Fasten the card to the chassis with the screw.

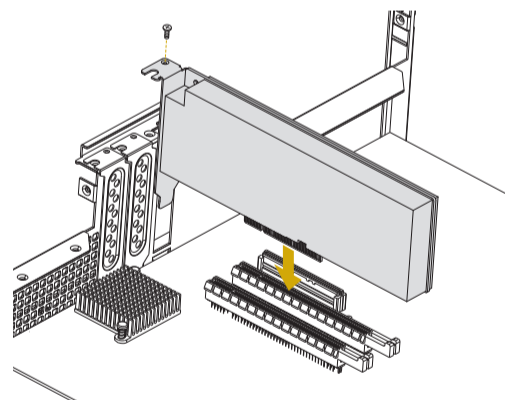

9 Install the M.2 SSD Module

- Find the corresponding nut location to be used.

No.	1	2
Nut Location	A (NUT80_1/2)	B (NUT110_2)
PCB Length	8cm	11cm
Module Type	Type2280	Type 22110

*M2_1 supports Type 2280 only.

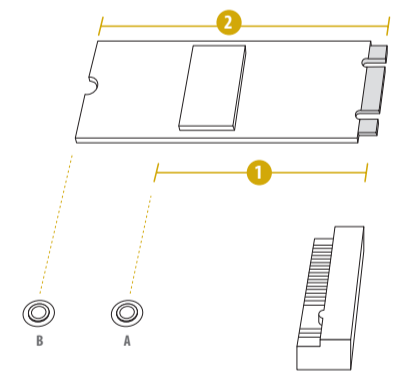

10 Install the Memory

- Unlock a DIMM slot by pressing the module clips outward.
- Insert the memory module.
- Lock the clips.

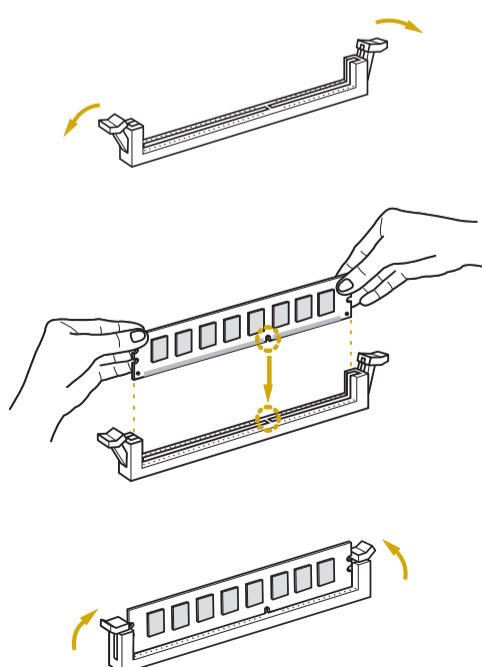

- Move the standoff based on the module type and length.



- Peel off the yellow protective film on the nut. Hand tighten the standoff into the desired location.



- Gently insert the M.2 module into the slot.

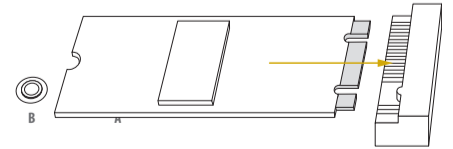

- Tighten the screw with a screwdriver to secure the module into place. Please do not overtighten the screw.

